



**Specification PTC 106: March 2008
Telecom Code of Practice for
Residential-Type generic cabling
Systems**

Access Standards
Telecom Corporation of New Zealand Limited
Wellington
New Zealand

March 2008

Copyright Telecom New Zealand Limited 2006



CONTENTS

Section	Page
Specification PTC 106: July 2006	i
Telecom Code of Practice for	i
Residential-Type generic cabling	i
Systems	i
Access Standards	i
Wellington	i
RELATED DOCUMENTS	iii
FOREWORD	iv
TELECOM DISCLAIMER	vii
1 INTRODUCTION	1
1.1 Scope	1
1.1.1 Application	1
1.1.2 Mode of Presentation	2
1.1.3 Intended Audience	2
1.1.4 Limitations on Customer Premises Wiring Work	3
1.1.5 Benefits of Compliance	3
1.1.6 On-going servicing by Telecom	3
1.2 Contracts and Obligations	3
1.2.1 Telecom Network Demarcation Point	3
1.2.2 Installer's Obligations	4
1.2.3 Customer's Responsibilities	5
1.2.4 Telecom Exclusions from Liability	6
1.2.5 Non-complying Installations	6
2 DEFINITIONS	7
3 OVERALL SYSTEM DESIGN & PROVISIONING	11
3.1 Technologies	11
3.2 Home system architecture	11
3.2.1 Recommended provision of TO's	12
3.2.2 Customer equipment power supplies	13
3.2.3 Restricted Locations	13
4 SYSTEM COMPONENTS	15
4.1 Trenching for the Telecom lead-in cables	15
4.2 Telecom-provided items	15
4.2.1 Lead-in cable	15
4.2.2 Entry Point for Residential and Small Business Premises	16
4.2.3 Connection of internal wiring to the Lead-in Cable	16
4.2.4 Customer-Located Network Equipment & Service Delivery Points	17
4.3 Home Distributor	17
4.3.1 Home Distributor and its location	17
4.3.2 Home Distributor Telepermit requirements	20
4.3.3 Disconnect Test Point	20
4.3.4 Cabling termination hardware within the Home Distributor	25
4.3.5 Cross-connections	25
4.3.6 Hardware for other services within the Home Distributor	26
4.4 Cables and related hardware	26
4.5 Telecommunications Outlets	27
4.5.1 Hardware type	27
4.5.2 Telepermit requirements	28
4.5.3 Labelling and identification	28
5 REQUIREMENTS FOR ALL CABLING SYSTEMS	29
5.1 Safety Requirements	29
5.1.1 General	29
5.1.2 Hazardous Voltages	29
5.1.3 Connection of 230 V and ELV/TNV on same TO faceplate	29

5.2	Cabling system performance	30
5.2.1	General Wiring Issues	30
5.2.2	Segregation of Services	32
5.2.3	Wiring under Floors	32
5.2.4	Wiring above Ceilings and in Walls	33
5.2.5	Wiring Within or Beside Concrete Structures	33
5.2.6	Surface Wiring	34
5.2.7	Wiring Between Buildings on Same Site	34
5.2.8	Wiring to Equipment Exposed to the Weather	34
5.2.9	Cleanliness	35
5.2.10	Water protection	35
5.3	Cross-connections and commoning of TO's	35
5.4	Connection of line-grabbing devices	35
5.5	Connection of Broadband services	36
5.6	Mounting Hardware	36
5.7	Faceplates and socket orientation	36
5.8	Cable termination	37
5.9	Wire mapping	37
5.10	Child safety precautions	39
5.11	CPE connection to Telecom lines	40
5.11.1	Connection options	40
5.11.2	Series-connected CPE	40
5.12	Earthing	40
6	COAXIAL AND SCREENED CABLING	41
6.1	General	41
6.2	SKY Digital service	41
6.3	VHF/UHF Television services	42
6.4	AV and audio distribution	42
6.5	Remote control facilities	42
6.6	Security cameras	42
7	INSTALLATION TESTING	43
7.1	Installer's obligations	43
7.2	Testing and Certification	43
7.3	Testing and Certification of coaxial connections	44
8	INSTALLATION RECORDS AND MAINTENANCE SUPPORT	45
8.1	Cabling Management	45
8.2	Support	45
8.3	Installation records	46
9	SPECIAL SITUATIONS	48
9.1.1	Door and Gate entry control systems for individual customers	48
9.1.2	Door and Gate entry control systems for two or more customers	48
APPENDIX No. 1 COMPLETION FORM FOR HOMES WITH GENERIC CABLING		
APPENDIX No. 2 SPECIAL REQUIREMENTS FOR HOMES CONNECTED VIA TELECOM'S FIBRE NETWORK		
APPENDIX No. 3 PROVISION FOR SKY DIGITAL SERVICES		
APPENDIX No. 4 OPTIONAL INSTALLATION COMPONENTS FOR OTHER SERVICES		
APPENDIX No. 5 OUTLINE OF "POWER OVER ETHERNET"		
APPENDIX No. 6 COAXIAL CABLING FOR BROADCAST TV, VIDEO, AUDIO, ETC		
APPENDIX No. 7 WIRELESS RETICULATION		

RELATED DOCUMENTS

PTC 100	Telecom Permit to Connect: General Conditions
PTC 103	Telecom Code of Practice for Residential-Type Customer Premises Wiring
PTC 222	Requirements for Customer Premises Cable
PTC 225	Requirements for Star Wiring Boxes and Small Office Home Office (SOHO) Cabling Systems

PTC 103, PTC 106 and PTC 225 are available free of charge from <http://www.telepermit.co.nz/PtcSpecs.html>

Lead-in details

URBAN Installation of Underground Lead-Ins for Telecom Residential Customers: Contractor's Information

This document is available free of charge from <http://www.telepermit.co.nz/Urban.pdf>

Electricity Regulations 1997

AS/NZS 3000	Australian/New Zealand Wiring Rules
AS/NZS 3080	Telecommunications installations – Generic cabling for commercial premises
AS/NZS 3085	Telecommunications installations – Administration of communications cabling systems
ISO/IEC 15018: 2005	Telecommunications installations - Integrated telecommunications cabling systems for small office/home office premises
AS/NZS 3112	Approval and test specification – plugs and socket outlets (230V)
ISO/IEC 15018	Information Technology – Generic cabling for homes
ISO/IEC 60603-7	Connectors for electronic equipment – Part 7: Detail specification for connectors, 8-way, including fixed and free connectors with common mating features.
Note: there are several parts to this Standard, covering different performance levels.	
IEC 61169-24	Radio-frequency connectors – Part 24: Sectional specification – Radio frequency coaxial connectors with screw coupling, typically for use in 75 ohm cable distribution systems (type F)
IEEE 802.3af	Power over Ethernet

FOREWORD

A customer's ability to make use of future services could be constrained by the lack of suitable cabling within the home. The current "telephone jackpoint" will gradually be replaced by an "any service" access point. This is referred to in this Code of Practice as a "Telecommunications Outlet" or "TO", but it can be used for supplying customer-provided services to the home system as well as delivering network and other services to the customer.

It is recommended that these TO's be located at multiple points within the home and, where necessary, that they be integrated with coaxial connectors for current TV distribution needs. Wireless technologies will no doubt supplement the fixed wiring in most cases, but fixed wiring can still provide the highest reliability, security and performance at a very reasonable cost.

With the recent development of "Power over Ethernet" standards, the TO also has the ability to provide power to the associated equipment, making it no longer necessary to provide a 230 V outlet close to each TO or to provide a separate 230 V plug pack power unit at each location. Obviously, this feature is not available via radio solutions.

At the very least, this Code of Practice should ensure that architects, building contractors and customers are made aware of the need to "think about" telecommunications in general and realise that its cabling is another key service within a home. It will be in the customers' best interests for telecommunications cabling requirements to be given a similar level of consideration as other building services, such as the heating, lighting, plumbing and drainage.

This Code of Practice is intended for use by professional installers involved in providing generic or "structured" cabling for telecommunications and other services in both residential and small business premises. The primary aims of this code are to recommend provisioning, and define methods and standards which will result in increased flexibility for future needs, good long-term performance and reliability. It deals mainly with the requirements for cabling directly or indirectly connected to Telecom's network, but also provides information on other transmission media and related issues. Because these are not of direct concern to Telecom, they have been included as Appendices to the main document.

In particular, the trend today is towards the "intelligent home", with increased integration between the various services in the home. Not just telephony and data, but broadcast TV, audio, video, security and building services control are all being brought together via a general purpose or "generic" cabling system capable of supporting multiple services.

Since ownership of premises telecommunications wiring passed to residential customers following the enactment of the Telecommunications Act 1987, customers now have responsibility for the maintenance, repair and modification of cabling and all related hardware. In the case of cabling installations covered by this Code of Practice, especially those using extensive proprietary

components, the original installing company or their nominated agent is likely to take over this responsibility via a service agreement with the customer.

Maintenance and repair of the cabling covered by this Code of Practice is not currently covered by Telecom's Residential Premises Wiring Maintenance Service.

Nevertheless, Telecom's "Standard Terms for Residential Customers" requires "all sockets and wiring which connect equipment to the Telecom network, to meet and be installed to our (Telecom's) specifications". Compliance with this Code will meet that obligation.

The development of Telecom's standard "2-wiring" system in 1996 led to the use of 2-pair cable for most new installations and additional lines. This has proved more than satisfactory for supporting current Telecom services, including broadband delivery. However, it is now clear that a wide range of new services will be available from Telecom's "Next Generation Network" and home LAN's are now commonly installed for a wide range of applications. This Code of Practice covers structured cabling similar to (and essentially only a "sub-set" of) what has been used in commercial buildings for some years.

Although Small Office/Home Office (SOHO) wiring systems have been used in many of the more expensive new homes and in offices for some years, most new homes have continued to install the much lower cost 2-wire system for Telecom network-based services. In 2003, Telecom Access Standards recommended adoption of "star wiring" for all new homes, using at least Cat 5 rated 4-pair cable in place of its standard 2-pair cable. This early recommendation included the standard "2-wire" jackpoint and was regarded as a "low cost preferred option" for all new homes on the basis that "getting the cable in the walls" is the immediate need. The cables can always be re-terminated later, as and when the need arises. Such simple "star wiring" is now considered the absolute minimum provision for a new home or office.

Developments in technologies and proposed future services now justify the provisioning of more extensive wiring and cross-connect facilities, which will not only provide the flexibility to support a wide range of future telecommunications services, but also provide for increased entertainment and building services as an essential part of the modern "intelligent home".

The focus is on residential type installations, but this code also applies to similar small-scale cabling systems used in business and commercial premises.

Recent years have seen significant changes from "Plain Old Telephone Service" to broadband data and Voice over IP. What new services will exist in the future is not known, but everything points to higher data speeds and an increased range of services.

In conclusion, most home cabling will be in place for the life of the home. Once installed, wiring is usually inaccessible and expensive to replace or augment. Wireless technologies will no doubt supplement the fixed wiring in most cases,

but fixed wiring can still provide the highest reliability, security and performance at a very reasonable cost.

The customer's best interests will be met by ensuring that the cabling they install today will at least have a reasonable chance of meeting their long-term requirements.

TELECOM DISCLAIMER

While every care has been taken, Telecom nevertheless makes no representation or warranty, express or implied, with respect to the sufficiency or utility of the information contained in this Code of Practice.

This Code sets out general principles for carrying out structured premises wiring and explains Telecom's mandatory and recommended practices. Nevertheless, it is obviously not practicable to cover every situation that may arise. In view of this, Telecom expressly advises that the use of or reliance on the information contained in this Code of Practice must take into account the customer's actual requirements and the conditions that apply at any particular premises.

Telecom shall not be liable for any loss (including consequential loss) damage or injury incurred by any person or organisation arising out of the sufficiency, accuracy, or utility of any such information or opinion.

1 INTRODUCTION

1.1 Scope

1.1.1 Application

(1) This Code of Practice is primarily concerned with the installation of residential customer premises telecommunications cabling intended not only for both direct and indirect connection to the Telecom network, but also for supporting other home services. The term “generic” is used to stress the point that such cabling will become the basis of a whole range of different services. The principles contained in the code also apply where the same types of wiring systems are used by business customers.

(2) It is strongly recommended that such generic cabling systems are installed for all new residential-type installations. These will provide the necessary flexibility and capability, not only to support a wide range of broadband-based services, with high security and long term reliability, but also to provide the home user with facilities to add, remove or re-arrange services wherever a suitable access point (Telecommunications Outlet or TO) is located. These facilities align with Telecom plans to introduce processes that will allow customers to add or change their services “on-line” without the need for a site visit and its attendant charges.

(3) Generic cabling systems can provide for Local Area Network (LAN), audio, video and home control system distribution within the premises. While these services may have no direct connection with the Telecom network, their cabling and cross-connections are covered in this code of practice because any cabling and its TO may be allocated to Telecom services at some time in its service life.

- *Telecom has no involvement or responsibility for the coaxial cabling and associated hardware used in many of these systems. Their installation and maintenance is left to the customer to arrange.*

(4) ISO/IEC 15018: 2005 provides for four exchange lines, but this is not mandatory for Telepermit purposes and suppliers may equip more or less capacity, as required by the customer.

(5) The systems described and the recommendations made in this document align with international standards. For this reason, the term “TO” or “Telecommunications Outlet” is used throughout this document, rather than Telecom’s usual term “jackpoint”. While the word “outlet” implies that signals and services are delivered to equipment plugged into such points, it is important to appreciate that any signals, including voice, data, audio and video, can also be transmitted into the home system at these points.

- *Most cable remains in service for many years – usually for the life of the building, so it is preferable to consider installing extra cable and TO’s when planning a new home. This will reduce the risk that additional cable will be needed in the future. It is recommended that TO’s and cabling additional to immediate requirements be provided at all potential CPE locations while*

the framing is still accessible for cable runs. This includes providing TO's for Home LAN applications and a TO by at least the main television set for digital TV programme control.

- *The one thing that is certain is that adding cable to a completed home is far more expensive than adding it to unlined framing. Full consideration of potential requirements at the planning stage of a new home is expected to pay off in the long term.*

(6) The cabling design for a new home needs to cater for the distribution of television and other entertainment services, for which it is also best to cable at the pre-lining stage. Coaxial cabling and related hardware, power supplies, etc, are not of direct concern to Telecom, but they are an important part of the overall cabling system. In view of this, these matters are covered briefly in Section 6 and in the Appendices to this Code of Practice.

1.1.2 Mode of Presentation

(1) Use of the word "shall" in this document identifies mandatory requirements for compliance with this code, "should" refers to practices, which are advised, or recommended, and "may" refers to matters which are optional.

(2) Mandatory requirements are highlighted for easy reference, as indicated in this clause.

(3) Clauses which are a formal part of this Code of Practice are numbered.

(4) Those which are added as explanations or background comments are printed in italics and with smaller text. For example:

- *RJ 45 TO's, star boxes, SOHO cabinets and their associated hardware are not covered by Telecom's wiring maintenance service.*

1.1.3 Intended Audience

(1) This Code of Practice is intended primarily for use by tradespersons and those carrying out telecommunications wiring on a commercial basis. Cabling hardware suppliers should find this code helpful when preparing installation instructions and user manuals for their products.

(2) The installer's competency in electrical and telecommunications wiring techniques and practices has been assumed. Accordingly, emphasis is placed on the installation requirements of the cable and hardware concerned and the need for service reliability under the wide range of New Zealand environmental conditions.

(3) Persons working on wiring operating at Extra Low Voltage or provided solely for telecommunications purposes and working at Telecom Network Voltages are exempted from registration under the New Zealand Electricity Regulations 1997. However, the safety requirements of the Electricity Regulations, AS/NZS 3000 and Telecom Codes of Practice must still be fully complied with.

(4) Some Telecom customers who wish to do work within their own premises, and who have an adequate knowledge of electrical and telecommunication terms and practices, should find this Code useful.

(5) Nevertheless, Telecom recommends the use of experienced professional installers where there is any doubt about what is needed to comply with this Code of Practice or the warranty terms of the equipment being used.

1.1.4 Limitations on Customer Premises Wiring Work

(1) Only customer-owned telecommunications wiring may be worked on by other than Telecom. The Telecom cable lead-in from the street and, where fitted, the Telecom network termination (usually an External Terminating Point (ETP)) are specifically excluded from access by other parties. This exclusion also applies to the secured parts of an Optical Network Termination (ONT), its associated power supply and inter-connecting cable, where these have been installed.

(2) Any customer-owned wiring serving two or more Telecom customers shall be worked on by other than Telecom only with the specific approval of all the customers concerned.

- *This exclusion applies to all Telecom-owned building cabling, such as that installed in high-rise residential blocks, and which services multiple customers. Such cabling is usually on the network side of the individual customer's network demarcation point.*

1.1.5 Benefits of Compliance

(1) Compliance with this Code of Practice will ensure that the installation is acceptable for connection to the Telecom network and that it can be expected to support all new technologies and services relevant to the rating of the system concerned.

(2) Compliance with this Code will contribute to reliable long term performance of the associated telephone and fax/data voice band services, ADSL and other broadband services, etc.

1.1.6 On-going servicing by Telecom

It is important that all parties concerned appreciate that Telecom does **NOT** currently, under its standard residential wiring maintenance service, maintain or repair the cabling, TO's, and terminating or cross-connecting hardware used for generic cabling systems.

- *The present service covers the replacement of BT jackpoints and repair of their associated wiring only. Where these have been installed in compliance with Telecom's requirements and failure has occurred due to normal use, these items are repaired free of charge on payment of a monthly fee.*

1.2 Contracts and Obligations

1.2.1 Telecom Network Demarcation Point

(1) The Network Demarcation Point forms the dividing line between Telecom's ownership of the network and a customer's ownership of the premises wiring. For most residential installations, this is the ETP, which is mounted on the outer

wall of the building. In some situations, such as apartment blocks, the demarcation point may be the Telecom Network Termination (TNT). Under current Telecom practices, the internal building cable connects to the Telecom lead-in cable within the ETP.

- For a home connected via Optical Fibre cable where an Optical Network Termination is installed for additional information refer Appendix No. 1.

(2) Where no ETP is fitted, the demarcation point is the point at which the cable enters the outer wall of the individual home or premises.

(3) Even though the lead-in cable from the network reticulation in the street may be run on private land, the lead-in cable and its associated pipe remain in Telecom's ownership. Where a customer changes to another network provider, that provider will install their own lead-in cable and generally connect to the premises wiring at the ETP. Where no ETP is fitted, the new provider will either install its own ETP or connect to the customer's wiring at Home Distributor.

(4) Telecom is responsible for its ETP, lead-in pipe and lead-in cable and for any of its own network equipment installed within the customer's premises for the purpose of providing the customer with network services.

(5) Telecom will, as part of its network service, service all equipment, cable and pipe on its side of the network demarcation point and any Telecom-owned network equipment installed on the customer's side of the demarcation point. Telecom will also service any customer premises equipment rented from Telecom. Such servicing will not be subject to a charge where faults are caused by normal service conditions.

(6) The customer will own and be responsible for arranging all servicing of wiring and terminating or cross-connecting hardware within their premises.

(7) The customer may choose to carry out their own wiring installation, changes and repairs, or call on any suitable contractor to carry out this work on their behalf.

1.2.2 Installer's Obligations

(1) In order to meet their obligations to their customers, installers need to be aware of several legal issues resulting from New Zealand consumer protection legislation, the Telecommunications Act, Electricity Regulations, and contractual obligations between Telecom and its customers. The following outlines these issues.

(a) It is the responsibility of the installer to ensure that wiring is carried out in accordance the Electricity Regulations 1997 (or superseding regulations) and with all other relevant legal requirements. These may vary according to the particular conditions that apply in the premises in which the wiring work is to be carried out. However, telecommunications wiring is NOT subject to routine inspection by Telecom or the provision of Certificates of Compliance under the Electricity Regulations.



- *Note that compliance with the relevant parts of AS/NZS 3000, the “Wiring Rules,” is required under the Electricity Regulations 1997.*

(b) Cabling and wiring may only be connected to the Telecom network with Telecom’s agreement. This agreement is granted as a matter of course for commercial installations using purpose–designed telecommunications components which have been installed in accordance with industry standards. For residential premises, it is a contractual obligation that all work must be done in accordance with Telecom’s Codes of Practice. Installations fully complying with this Code of Practice will be regarded as meeting Telecom’s requirements for connection to its network.

(c) Premises wiring provided on a commercial basis on behalf of residential customers is subject to the terms of the Consumer Guarantees Act, 1993. This requires that the materials supplied and the manner in which the work is carried out shall be fit for its intended purpose. If wiring is not acceptable to Telecom, it is clearly not fit for the purpose of connecting to the Telecom network.

- *Similarly, with high performance cabling of the type described in the Code of Practice, it is important that the completed installation is tested to confirm that there are no faults impacting on the expected performance and “suitability for its intended purposes”.*

(d) Those persons involved in providing premises telecommunications wiring for commercial customers are required to comply with the Fair Trading Act 1986.

(2) To meet conditions (b) and (c) above, installers shall clearly notify the end customer that the installation and materials used in compliance with this Code of Practice are not covered by the wiring maintenance services currently provided by Telecom.

- *This is normally achieved by giving oral advice to the customers concerned, together with clear warnings in marketing brochures and user guides, and by placing warnings on the inside of the home distributor door or cover.*

1.2.3 Customer's Responsibilities

(1) Compliance with this code by customers, or by their installers, will enable customers to meet their legal obligations in receiving service from the Telecom network.

(2) Where service problems are found to be due to premises wiring of a poor standard, incorrect cross-connections, or the failure of hardware not covered by Telecom’s wiring maintenance services, it will be the customer's responsibility to pay for the service call and for any repairs if called on to do so by Telecom.

(3) The customer is responsible for making use of any test facilities provided before calling either Telecom or the contractor charged with maintaining the wiring installation.

- *Failure to do so will result in a service call fee should Telecom be called in to sort out problems within the premises cabling. Similarly, other repair staff will no doubt charge if the fault is found to be within the Telecom network.*

1.2.4 Telecom Exclusions from Liability

- (1) Telecom reserves the right to disconnect any non-Telecom services or equipment making use of the same premises wiring, should such services or equipment have led directly or indirectly to the disruption of Telecom services.
- (2) Telecom accepts no liability for repair or re-connection of such non-Telecom services or equipment where its re-connection would again disrupt a Telecom service.
- (3) Telecom accepts no liability for damage caused to customer equipment by over voltage which may occur on Telecom lines due to fault conditions, lightning or for any other reason.

1.2.5 Non-complying Installations

- (1) Non-complying new installations may require remedial work to be undertaken at customer expense before being connected to the Telecom network. Likewise, non-complying modifications to existing installations may subsequently incur costs to the customer if unsatisfactory service results.
- (2) This Code of Practice need not be applied retrospectively. Any existing non-complying wiring may remain connected to the Telecom network provided that it does no harm to the Telecom network, and does not result in unsatisfactory connections for either the customer concerned or for other parties attempting to communicate with the customer.

2 DEFINITIONS

Accessory: any device, not itself directly providing a telecommunications function, which is plug connected to the premises wiring.

BT jackpoint: any jackpoint which mates with a plug to BS 6312.

Category: a means of identifying the performance of cable.

- *Cable performance is defined in relation to the overall transmission capability of links and channels defined in international standards. In simplistic terms, “Cat 5” rates cable for frequencies up to 100 MHz and data rates up to 100 Mbit/s, “Cat 6” rates cable for frequencies up to 250 MHz, and “Cat 7” rates cable for frequencies up to 600 MHz, when used on links of up to 90 m in length. The rated performance is generally more easily achievable on shorter cable runs.*

Cross-connection: any arrangement which enables a jackpoint to be associated with a specific service

Customer-located network equipment (CLNE): Telecom-owned network terminating equipment required to provide a specific Telecom service and located within the customer’s premises on the customer’s side of the network demarcation point

Customer premises equipment (CPE): any telecommunications terminal equipment connected to the customer’s wiring, other than CLNE.

Daisy-chain (or loop) wiring: a common form of wiring where a cable to one jackpoint is connected to another cable to the next jackpoint.

Demarcation point (or network demarcation point): the point at which the Telecom lead-in cable enters the customer’s building and, usually, also the point at which the customer’s wiring is connected to the network lead-in cable.

Disconnect Test Point: a device incorporated into a Home Distributor to provide a simple means of isolating the premises cabling and CPE from the Telecom line for test purposes.

- *refer PTC 225 for further details on the Disconnection Point.*

External cable: cable intended for installation outside buildings, exposed to the weather or ground contact, and provided with an appropriate protective sheath.

External Terminating Point (ETP): an external box, in which the lead-in cable is connected to the internal building wiring. It is also (incorrectly) known as External Test Point, the Network Termination Device or demarcation point, when provided.

Generic cabling: often referred to as “structured cabling”, a cabling system capable of supporting a wide range of services which is installed without detailed knowledge of the required applications.

Hardware (or line hardware): any fixed wired device other than CPE.

Home Distributor: the central point of a generic cabling system, consisting of a cabinet or cupboard housing cross-connection and test facilities for the premises cabling and associated services.

IDC: Insulation Displacement Connector commonly used to terminate wiring at hardware.

Inside cable: telecommunications cable intended only for use within a building.

Jackpoint: any type of outlet used for plug-connecting CPE.

Jumper: a hard-wired cross-connection (not using plugs and sockets).

Keystone: an RJ45 module of standardised dimensions facilitating a range of associated faceplate styles and inter-changeability of modules for repair or replacement purposes.

- refer IEC 60603-7 for the physical details of the RJ45 connector.

Lead-in cable: the Telecom owned cable used from the street to the customer’s premises.

Line grabbing: a function of series connected CPE which disconnects other wiring and CPE from the line to either terminate or initiate a call.

- Examples are medical and security alarms programmed to call a pre-determined number when triggered independent of whether the line is already in use.

Low Voltage (LV): any voltage exceeding 42.4 V peak a.c or 60 V d.c., but not exceeding 1000 V peak a.c or 1500 V d.c.,

- 230 V wiring is defined as Low Voltage and must be segregated from telecommunications wiring as explained in clause 5.2.2.

May: refers to matters which are optional.

Network Termination device: any device which terminates Telecom’s public network.

- For copper-based telephone lines, the usual network termination is the ETP. However, other devices may be encountered where service is delivered via radio or optical fibre. An example is the Optical Network Termination (ONT).

Optical Network Termination (ONT): a unit provided by Telecom to terminate its optical fibre lead-in cable.



Pair: any set of two wires, which are usually twisted in a cable, used to provide a circuit.

Patch cord: a means of cross-connection using plug-ended cords between the socket terminating the associated jackpoint cable and the socket used for the service being connected.

Residential-type: a general term to describe wiring systems intended mainly for residential customers' premises, but also commonly used for small business applications.

RJ 45: a general term used to describe the 8-way modular socket or associated plug originally used in North America and now standardised internationally.

- See IEC 60603-7 and related standards

Series CPE: any CPE connected in the path between other CPE and the network.

Shall: is used within the specification and that identifies the mandatory requirements for compliance with the specification.

Should: is used within the specification and that identifies the recommended practices for agreement with the specification.

Socket: the term used to describe the specific type of socket component incorporated in "jackpoint" or "telecommunications outlet".

SOHO (Small Office/Home Office) cabling: an optional cabling standard, typically used for those installations requiring additional flexibility for voice and data services, and currently standardised in ISO/IEC 15018: 2005.

Star wiring: an arrangement whereby each jackpoint is separately cabled to a central point, where cross-connect facilities may be provided.

STP (Shielded Twisted Pair): balanced pair cable with some form of shielding for improved EMC compatibility.

Structured cabling (often referred to as "Generic" cabling): multi-purpose high performance cabling systems installed to AS/NZS 3080 or equivalent standards.

Telecom: Telecom New Zealand Ltd including, for the purpose of this Code of Practice, its staff and accredited service technicians.

Telecommunications Outlet (TO): the international term to describe any type of socket or jackpoint into which terminal equipment may be connected.

Telepermitted: CPE, hardware or cable marked with a Telecom "Telepermit" label to indicate that it complies with Telecom specifications.

Telephone hub: any form of communing facility, typically used to provide terminations where multiple TO's are to access the same telephone line

Test termination: a sealed resistor/capacitor combination usually fitted within an ETP to provide a remote line test capability independent of whether any CPE is connected to that line.

TNV (Telecommunications Network Voltage): a non-hazardous class of voltage for safety rating purposes, subdivided into three sub-classes.

- *TNV-1 normal operating voltages do not exceed SELV (Safety Extra Low Voltage, which does not exceed 42.4 V peak a.c or 60 V d.c.) but could be subject to over-voltages from a network. TNV-2 normal operating voltages do not exceed SELV and are not subject to network over-voltages. TNV-3 normal operating voltages do exceed SELV and are subject to network over-voltages. Because of ringing voltage and the possibility of mains contacts or lightning transients, a PSTN line and the wiring directly connected to it are rated at TNV-3. Wiring carrying Ethernet is rated at SELV.*

Two-wire (2-wire): the present standard BT jackpoint system where one pair interconnects all 2-wire TO's, each of which incorporates a capacitor to ring older 3-wire connected CPE.

UTP (Unshielded Twisted Pair): the more commonly used type of balanced pair cable (as distinct from STP) in New Zealand.

Voiceband: frequencies up to 4 000 Hz and, in particular, the nominal frequency range 300 Hz – 3400 Hz used for voice transmission

Wiring (premises wiring): all cable and directly connected hardware on the customer's side of the demarcation point.

3 OVERALL SYSTEM DESIGN & PROVISIONING

3.1 Technologies

(1) A typical “intelligent home” will make use of a range of technologies and practices. These include:-

- Cat 5 or better UTP cable and RJ45 connectors, primarily for telephony and data, but also capable of supporting other services, such as audio and video, home control, etc;
- RG 6 coaxial cable and “F” connectors for TV baseband applications, including free to air services. For satellite TV, see Appendix No. 3;
- Other types of cable for control systems for lighting, heating control, security, etc.
- Wireless services, such as WiFi (IEEE 802.11 variants), cordless telephones, etc.

(2) This Code of Practice deals primarily with cabling and hardware connected to the Telecom network although, for completeness, brief mention is made of these other options in the Appendices.

3.2 Home system architecture

(1) This Generic cabling system is a “multi-service” development of the earlier SOHO cabling system (see PTC 103 and ISO/IEC 15018: 2005). Like that version of SOHO, it is based on “star wiring” using high performance 4-pair UTP cable.

- *ISO/IEC 15018: 2005 was derived from the American standard EIA/TIA 570 and closely followed US practices at that time. Up to four exchange lines are catered for and the US version commonly makes use of multi-line telephones or adapters, which are rarely used in New Zealand.*
- *ISO/IEC 15018: 2005 is expected to be superseded by a new edition based on ISO/IEC 15018. This is, in most respects, a sub-set of “Generic cabling for commercial premises”, as specified in AS/NZS 3080 (ISO/IEC 11801), but with commoning facilities and not necessarily including backbone cabling.*

(2) Typically, up to four network lines are provided for, although there is no fixed number mandated by Telecom. Similarly, any number of TO’s may be installed.

(3) The basic concept is that all TO’s are essentially “general purpose” and able to support a range of services, depending on how they are connected at the Home Distributor. Also, each TO can be used to transmit and/or receive information, depending on the type of equipment connected to it. As such, TO’s are essentially “access points”, rather than just “outlets” as the name implies.

(3) A key component is the Home Distributor, to which all cabling is routed. This houses the necessary commoning and cross-connection facilities, test access point and other relevant hardware, along with the records needed for effective management of the installation. Each TO uses a separate run of cable to the Home Distributor, with no looping to second or subsequent TO's. This provides maximum flexibility to cover future needs at any TO location.

- *The overall trend is for the various services to become more integrated, with voice, video and data all delivered over a common path. Similarly, services within the home are expected to become remotely accessible.*

(4) A simple example of this architecture is shown in Fig. x below.

3.2.1 Recommended provision of TO's

(1) The total number of TO's that may be installed in any premises is not restricted. In fact, the installation of TO's on a fairly lavish basis is encouraged as a way of meeting unplanned and, as yet, unknown future requirements.

(2) It is recommended that two RJ45 sockets be installed at each TO location, with the following regarded as the minimum number to be installed in any new home:-

- at least one set of two in every room normally used by the occupants on a daily basis (kitchen, lounge, rumpus room, study, etc, other than "wet rooms" such as bathrooms, shower rooms, or laundry);
- at least one set of two in every room that is intended as a bedroom;
- one set of two located within 1 metre of each television antenna outlet location;

- *Combining the two RJ45 TO's with a coaxial "F" connector on the same faceplate is recommended for maximum flexibility.*

- *With Power over Ethernet installed, these TO's can also be used to provide power to the associated equipment, whether it be telecommunications network-related or quite separate items such as security cameras and building control devices. This avoids the need for every TO to be located close to a 230 V power outlet.*

(3) It must be stressed that the above is regarded as the **minimum** provision of TO's. It is recommended that due regard be given to the likely needs of the customer, especially for larger rooms, to avoid long equipment cords, and for those rooms where additional access points are likely to be needed at more than one location. For example, there may be two or more "likely locations" for the television set and/or personal computer in the main family rooms. Location of an access point within 1 metre of a television outlet permits the installation of a SKY Digital Decoder at any likely television set location.

(4) These TO's may also include provision on the same faceplate for one or more co-axial connectors, antenna or audio connectors, or other Extra Low Voltage services.



3.2.2 Customer equipment power supplies

- (1) Generic cabling systems are obviously intended for supporting a wide range of services, the terminal equipment for which will often be 230 V powered. For full flexibility of service provisioning, there should be a 230 V outlet in close proximity to the TO's for powering the associated equipment.
- (2) An alternative approach is to make use of "Power over Ethernet" (PoE) for any equipment that draws less than 15 W and is intended to be powered direct from the TO. Suitable power supplies and terminal equipment designed for Power over Ethernet are expected to be more widely available in the future. Where space is available, such power equipment is best installed within the Home Distributor. Appendix No. 5 includes a brief description of PoE.

3.2.3 Restricted Locations

- (1) TO's or other termination hardware shall not be sited where they are subject to dampness or dirty conditions, to excessive heat, or where they are likely to be subjected to mechanical damage. This precludes location outside a building, in bathrooms, showers and laundries, as well as on obviously damp or insecure walls.
- (2) TO's or other termination hardware shall not be mounted less than 300 mm above the finished floor level.

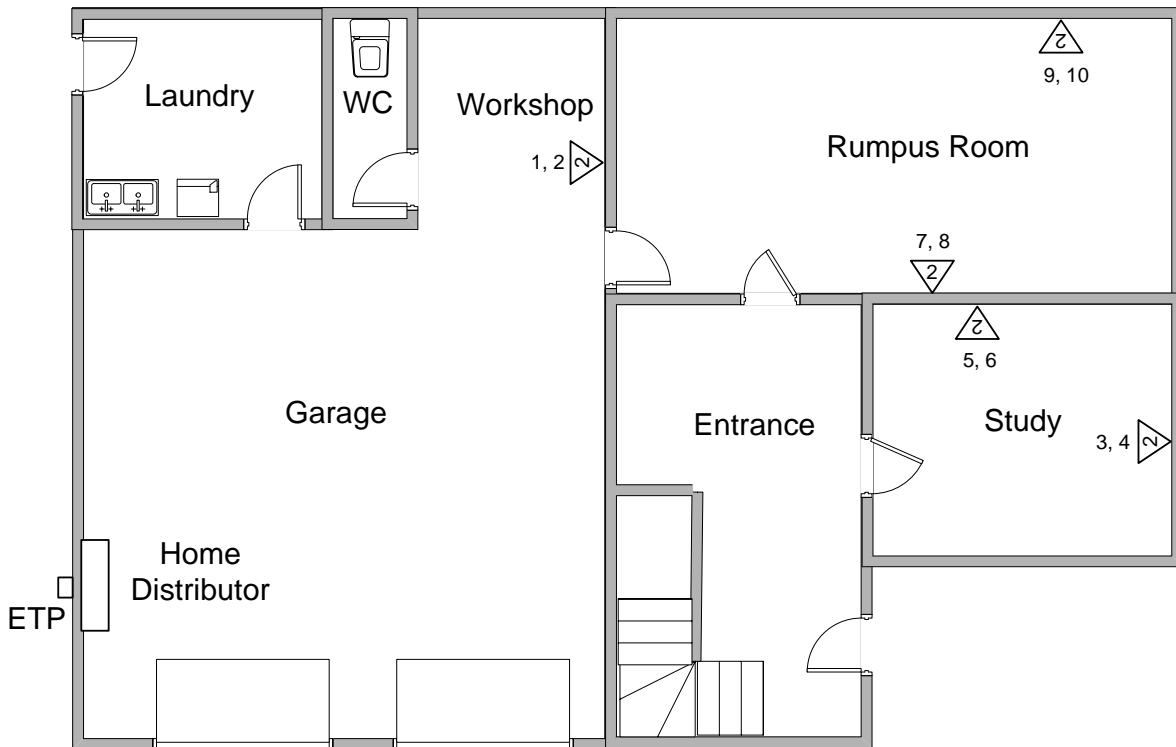
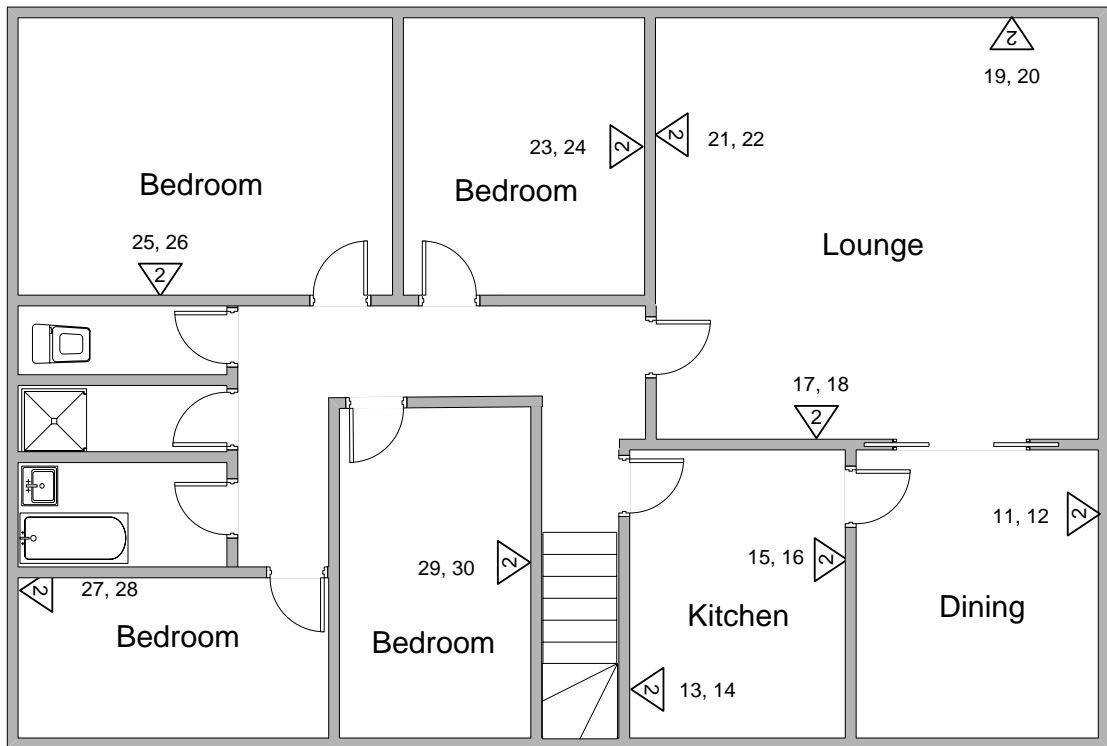

Individual Cat 5 cables installed between each TO and Home Distributor - not shown for clarity



Indicates dual RJ45 TO and TO reference numbers in cable records

4 SYSTEM COMPONENTS

4.1 Trenching for the Telecom lead-in cables

(1) The provision of suitable trenching for all services is the responsibility of the customer or building contractor acting on the customer's behalf. The contractor or his agent is to liaise with Telecom to determine the most appropriate point on or in the building to fit the Network Termination (typically an External Termination Point or "ETP") and the route for the trench.

(2) Lead-in cable or pipe can share a common trench with other services, subject to adequate protection against hazards or damage. As far as the Telecom services are concerned, requirements are fully defined in Telecom documents:

(a) "URBAN Installation of Underground Lead-Ins for Telecom Residential Customers: Contractor's Information". This is available from:-
<http://www.telepermit.co.nz/Urban.pdf> or

(b) "RURAL Installation of Underground Lead-Ins for Telecom Residential Customers: Contractor's Information". This is available from:-
<http://www.telepermit.co.nz/rural.pdf>

(3) The customer or building contractor acting on the customer's behalf is responsible for back-filling the lead-in trench, ensuring there is at least 300 mm cover over the lead-in pipe.

4.2 Telecom-provided items

4.2.1 Lead-in cable

(1) Telecom will provide and lay the lead-in cable and its readily identifiable "green pipe" as part of its network service and will continue to own these components. These items will be supplied free of charge by Telecom and remain Telecom's property. Telecom will make the necessary connections to the network and, at the network entry point, to the fixed wiring within the premises. This work is done as part of Telecom's service connection fee.

(2) In most cases, the network cable terminal is located on alternate section boundaries at the road frontage and the lead-in is run across the customer's land to the ETP. In the case of back-sections without a public road frontage, it may be necessary for the lead-in to pass over or under land owned by parties other than the customer concerned. In such cases, those parties will be required to formally agree to such crossings before Telecom can do the installation work.

- *This will usually require a formal easement to be written into land records, such that a subsequent owner of the land cannot demand that the cable is removed.*

4.2.2 Entry Point for Residential and Small Business Premises

(1) If not already provided, Telecom will arrange installation of an individual lead-in cable and ETP, or a distribution point for premises requiring a larger number of connections. For residential buildings where each unit has a street frontage, the ETP location will generally be on the wall facing the street or on a side wall close to the corner with the front wall, with clear access to the cable terminal on the road frontage. The ETP will be mounted at a minimum of 300 mm above the finally intended ground level for underground lead-ins and on a gable end or fascia board for overhead lead-ins.

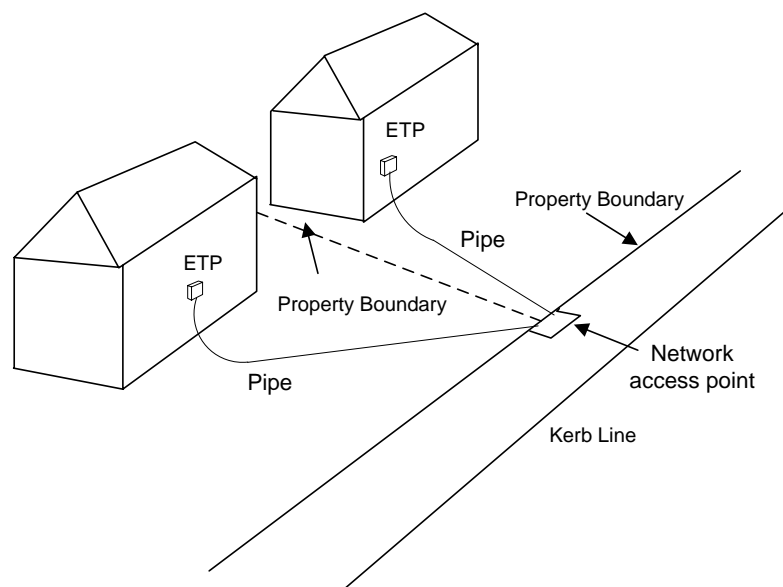

(2) For new premises, a suitable entry point location for connection of the customer's wiring should be selected. The general location is normally arranged with the developer for new sub-divisions, and is usually obvious from adjacent properties in developed areas. In cases of doubt, Telecom will provide guidance on receipt of advance application for service from the customer.

(3) The ETP is not to be located below and close to a hose tap, where it could be subjected to pouring water or continuous dripping.

4.2.3 Connection of internal ETP wiring to the Lead-in Cable

Independent of the number of TO's and cables installed, three 4-pair Cat 5 or higher performance cables shall be extended from the Home Distributor to the location of the ETP. 1 m tails shall be left at this point. These cables will be connected to the lead-in cable by Telecom.

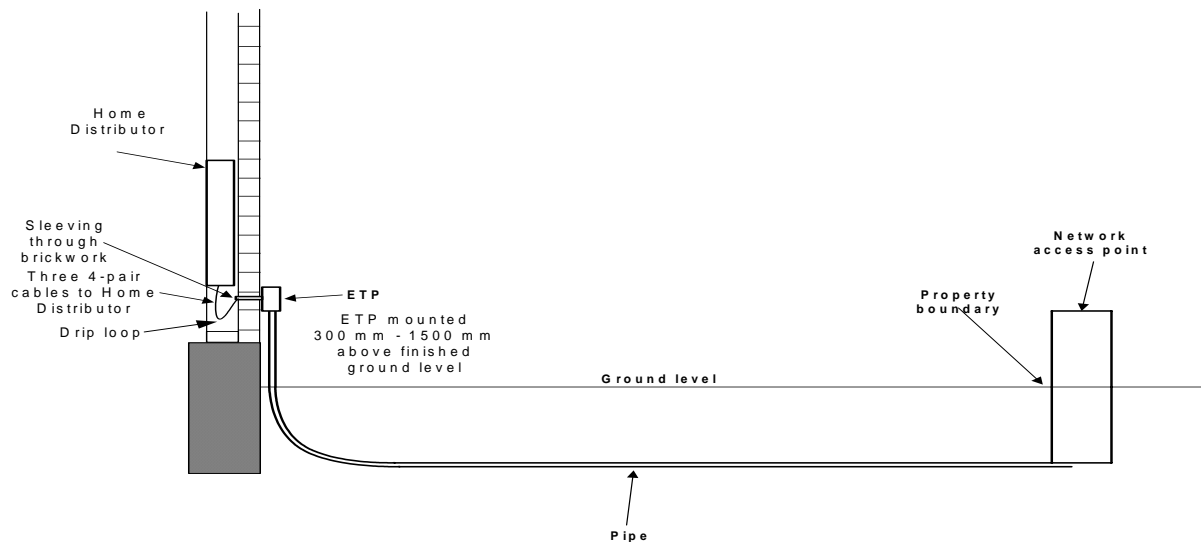

TYPICAL LEAD-IN ARRANGEMENT AND CONNECTION TO HOME DISTRIBUTOR

(2) The cabling installer shall co-operate with Telecom in respect to the timing of cabling and termination work in order to avoid unnecessary complications for either party.

4.2.4 Customer-Located Network Equipment & Service Delivery Points

(1) Although the Telecom network physically ends at the network demarcation point, there will be some situations that require Telecom-owned network equipment to be installed within the customer's premises to support network services. Whether or not such equipment is connected via customer-owned wiring, the customer's side of this equipment is termed a "Service Delivery Point".

(2) Where necessary, Telecom will define the type of network equipment and its location (service delivery point) according to the particular application. In most cases, such equipment is supplied, installed and commissioned by Telecom as an inherent part of providing the service concerned.

(3) Depending on the type of equipment concerned and the space available, such customer-located network equipment may be housed within the Home Distributor, with the relevant service delivery point(s) then connecting into the home cabling system via patch cords or jumpers.

4.3 Home Distributor

4.3.1 Home Distributor and its location

(1) The home distributor is essentially a cabinet or cupboard in which the cable termination hardware and other components are housed.

The PTC Specification for Home Distributors is PTC225

(2) The home distributor cabinet in all new installations shall be mounted immediately behind and above the ETP on the inside of the wall.

- This may impact on the location of the ETP

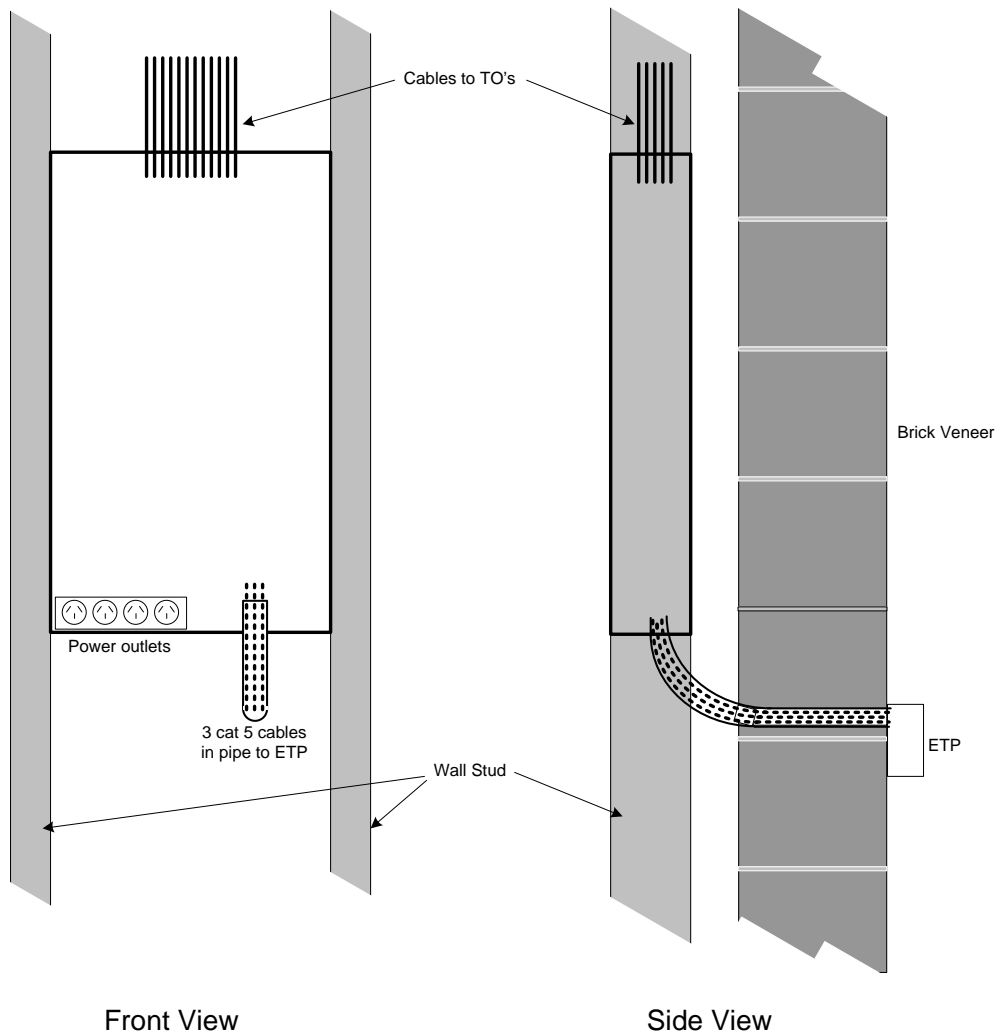

Location of Home Distributor Cabinet

(3) In existing homes, where access to the wall behind the ETP is not practical, the home distributor shall be mounted as close as possible to the ETP (on an inside wall), or arrangements should be made to shift the location of the ETP.

(4) The home distributor shall not be located in a damp area such as a bathroom, kitchen or laundry.

(5) The home distributor shall be at least 600 mm(high) x 350 mm (wide) x 75 mm (deep).

- *It is recommended that the cabinet is larger than this where practical.*

(6) There shall be at least 1 m clear space in front of the cabinet.

(7) At least one 230V outlet shall be provided within the home distributor cabinet.

- *It is recommended that there should be space for either a multi-outlet power board or at least four 230V outlets.*

- *A fully equipped home distributor may contain an ADSL modem, a Router or Ethernet hub, an Analogue Terminal Adapter, and a Video distribution amplifier all requiring a separate power supply.*

(8) The cabinet shall have suitable ventilation or forced cooling to allow for the continuous operation of any electrical equipment installed.

(9) Where practical accessible cable pathways should be provided to other parts of the premises such as ceiling cavities, to allow for the installation of additional cables in the future.

(10) A good level of lighting should be provided to facilitate maintenance etc.

(11) As part of Telepermit Specification PTC225, all home distributors shall be fitted with a "Disconnect Test Point" (DTP). The DTP serves two purposes:

(a) It allows the isolation of the premises wiring from the network, which enables a simple test to determine whether a fault is in the network or in the premises.

(b) It provides a connection point for either a DSL splitter where DSL and POTS are delivered over the same copper pair, or a Gateway device where data and voice are delivered over DSL, and there is no copper based POTS. This is known as "Naked DSL".

(12) In order to standardise the connection of DSL Splitters or Gateways, the DTP connectors and pin connections are defined in PTC225, and repeated in this Specification (Clause 4.3.3).

(13) There is also a requirement for the Home Distributor to include the provision for connecting a "Line Grabbing" alarm system between the DTP and the POTS commoning strip. A typical implementation is shown in the diagram in clause 4.3.3.

(14) The DTP and the provision for connecting alarm may be implemented as a standalone unit so that it can be used with the older wiring code described in PTC103. A separate PTC Specification (PTC227) documents the details for the standalone unit.

4.3.2 Home Distributor Telepermit requirements

(1) Commercially supplied products providing a Home Distributor function and connected to the Telecom network shall meet the requirements of Telecom specification PTC 225 and be Telepermitted in accordance with section 106 of the Telecommunications Act 2001 and ISO/IEC 15018: 2005 clause 5.3.2.3. Such products shall bear a Telepermit label.

- *This requirement applies, independent of whether the product is called a "Home Distributor" by the supplier.*

(2) The conditions for the grant of a Telepermit to such equipment are covered in Telecom Specification PTC 225.

- *Telecom specification PTC 225: 2003 is available free of charge from <http://www.telepermit.co.nz/PTC225draft.pdf>.*

- *Any purpose-designed cabinet and hardware is usually acceptable providing it meets the technical requirements of at least Category 5. The only mandatory Telecom requirements are the provision of a suitable Disconnect Test Point, with clear instructions on its use, and warnings to ensure that users are aware that the installation is not covered by Telecom's premises wiring maintenance service.*

(3) The requirement for commercially-designed and supplied Home Distributor cabinets to hold Telepermit does not extend to those units which are custom-designed for each installation and consist of commercial components fitted in a cupboard. However, such installations are still required to comply with this Code of Practice and use purpose-designed components.

(4) Some cabling components, such as telephone hubs, have been granted Telepermit. This indicates that they have met Telecom's requirements for the relevant class of device.

4.3.3 Disconnect Test Point

(1) A disconnect Test Point (DTP) shall be fitted to each incoming line.

(2) The incoming line shall be terminated on pins 4 and 5 of an RJ 45 socket and labelled "External".

(3) The outgoing line shall be terminated on pins 1 and 2 of the same socket and also pins 4 and 5 of a second socket labelled "Internal".

(4) The outgoing line shall be connected to an arrangement to which a line grabbing alarm system may be connected.

(5) Where there are more than one incoming line, the alarm connection arrangement may be limited to one line .

(6) The wiring arrangement for the DTP is shown below.



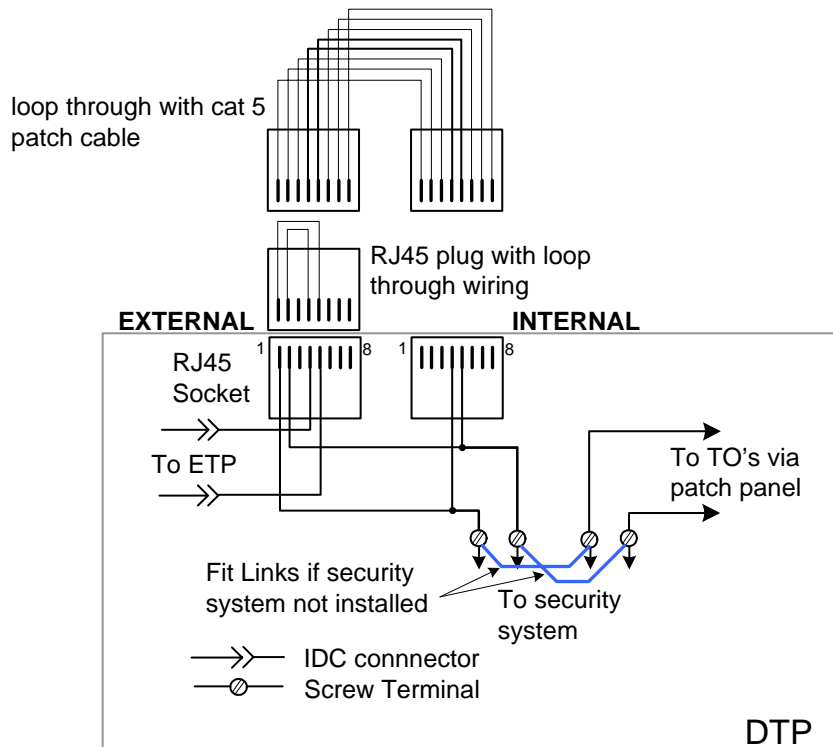

Notes:

Connection arrangement for security system only mandatory on line 1 in multiline installations.

The circuit between the external network and internal premises wiring can be completed with either a single RJ45 plug with pins 1 connected to pin 5 and pin 2 connected to pin 4, or a standard cat5/RJ45 patch cable.

The Security Industry typically use stranded cable hence screw terminals are shown. This is a recommendation and is not mandatory.

Wiring Details for the Disconnect Test Facility

(7) The figure below shows how a DSL splitter is connected at the DTP.

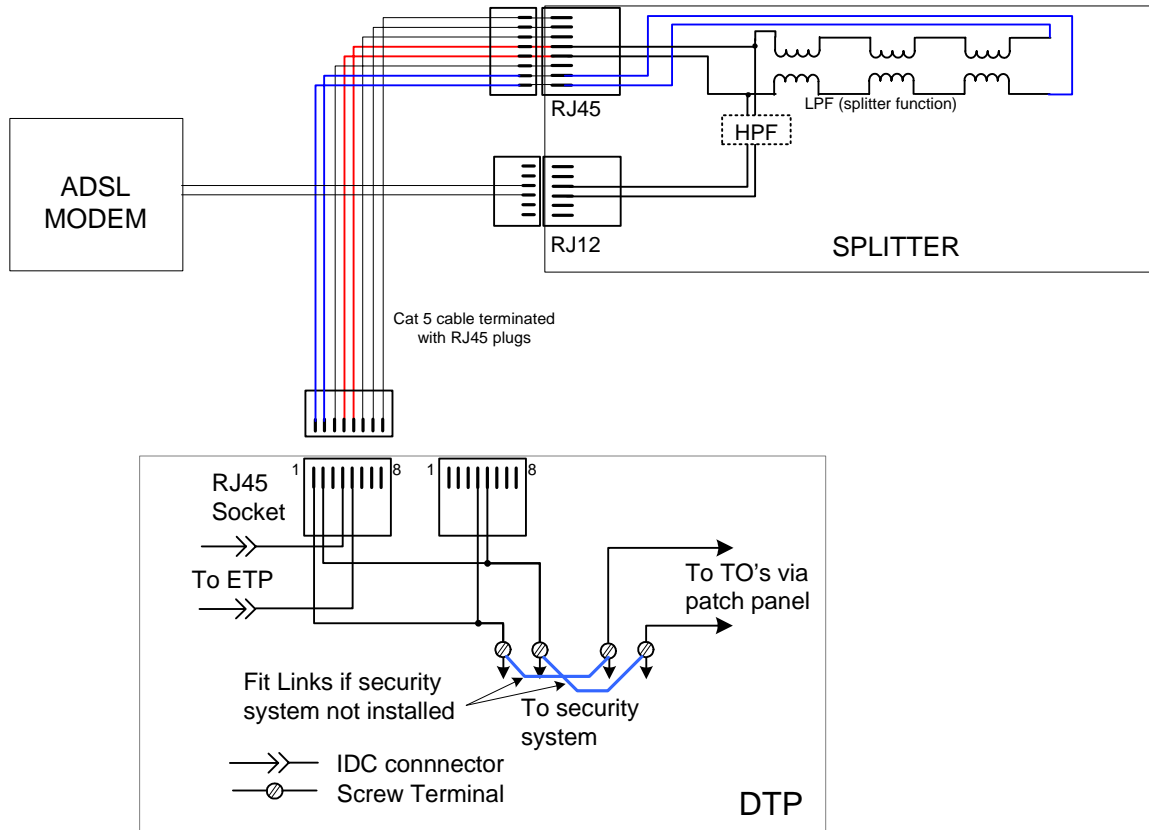

Connection of DSL Splitter at DTP using single cable

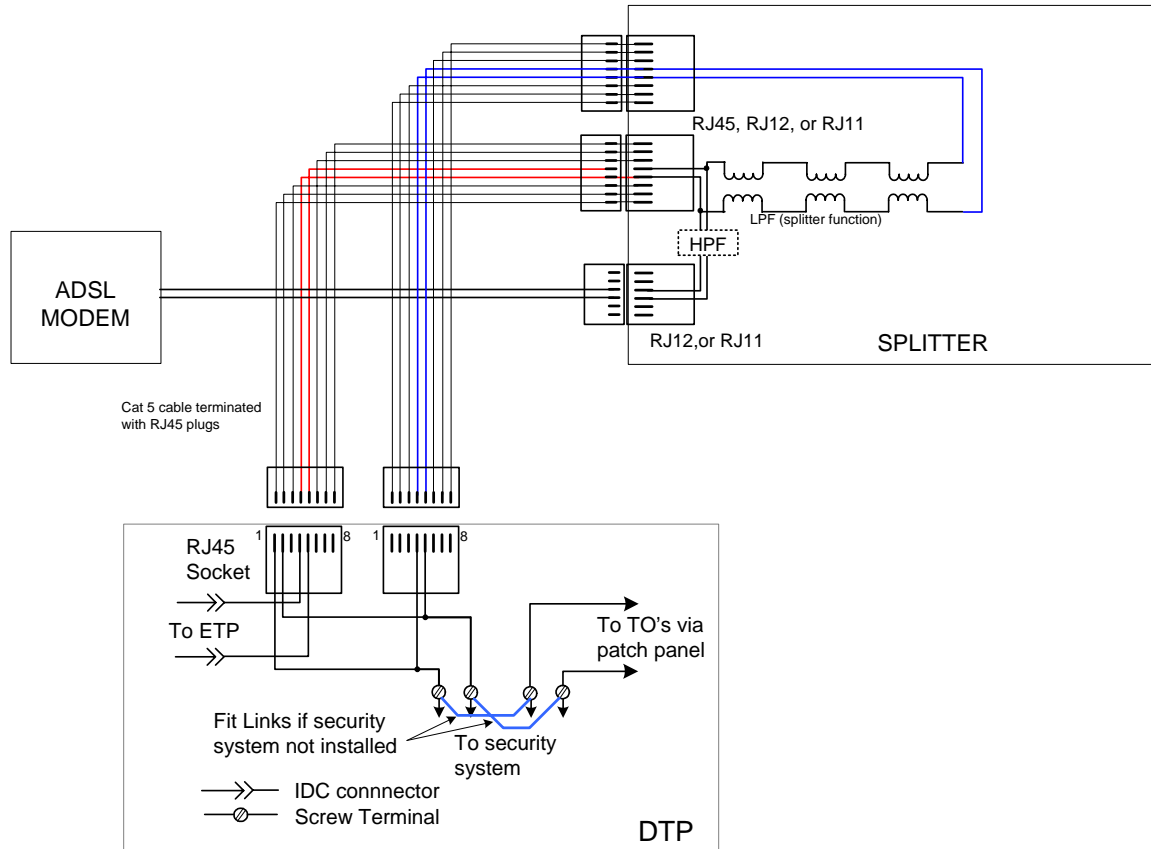

Connection of DSL Splitter at DTP using two cables

Notes:

The splitter can be patched to one of the TO's, allowing the modem to be located anywhere in the premises. This would be necessary if the modem/computer connection was via USB.

Alternatively for modems with Ethernet interfaces, the Ethernet port could be patched to a TO directly or to multiple TO's via a hub or router located in the home distributor cabinet.

(8) The Figure below shows how a Residential Gateway (RG) would connect to the DTP.

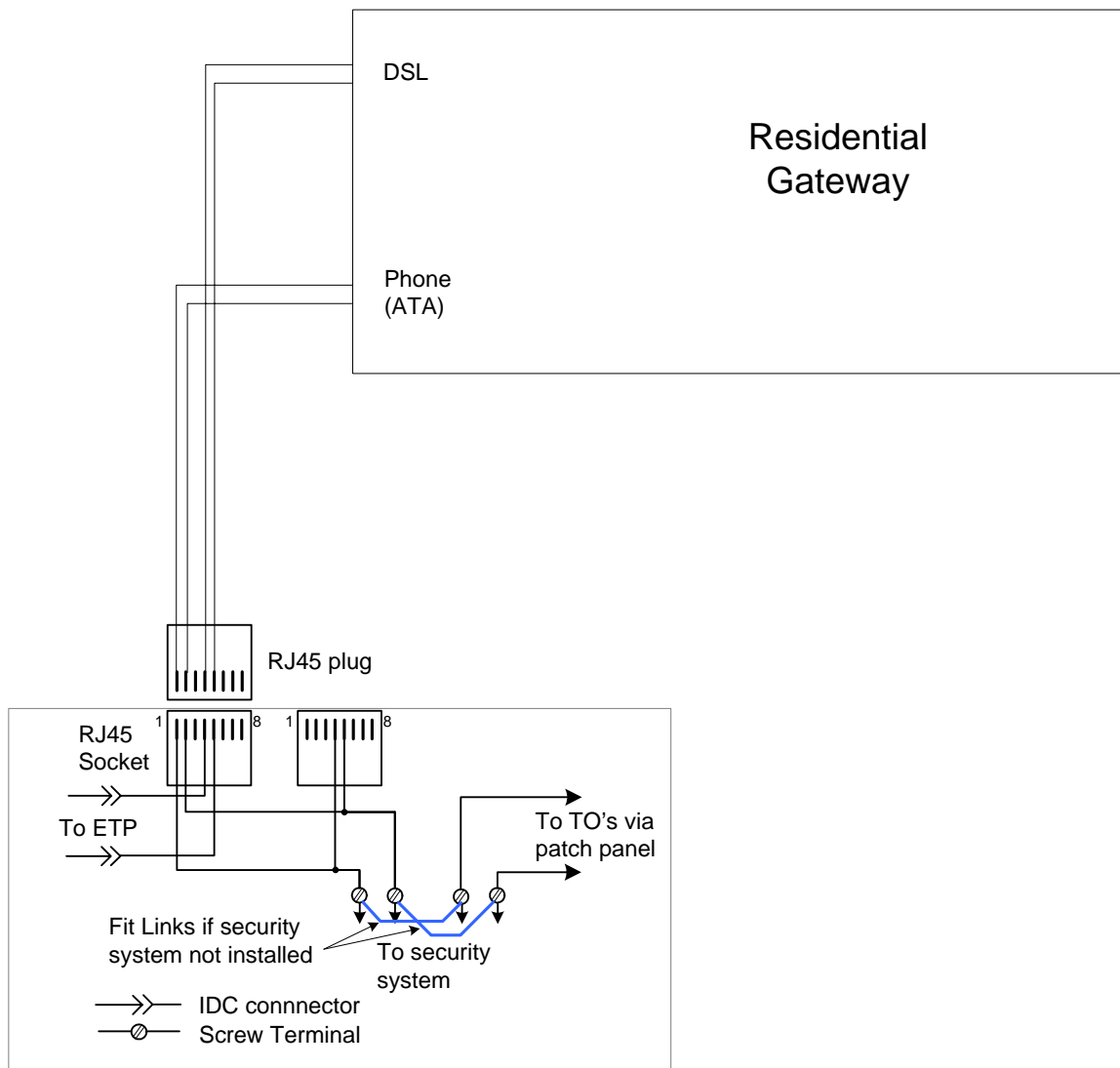

Connection of a Residential Gateway to a DTP using single cable

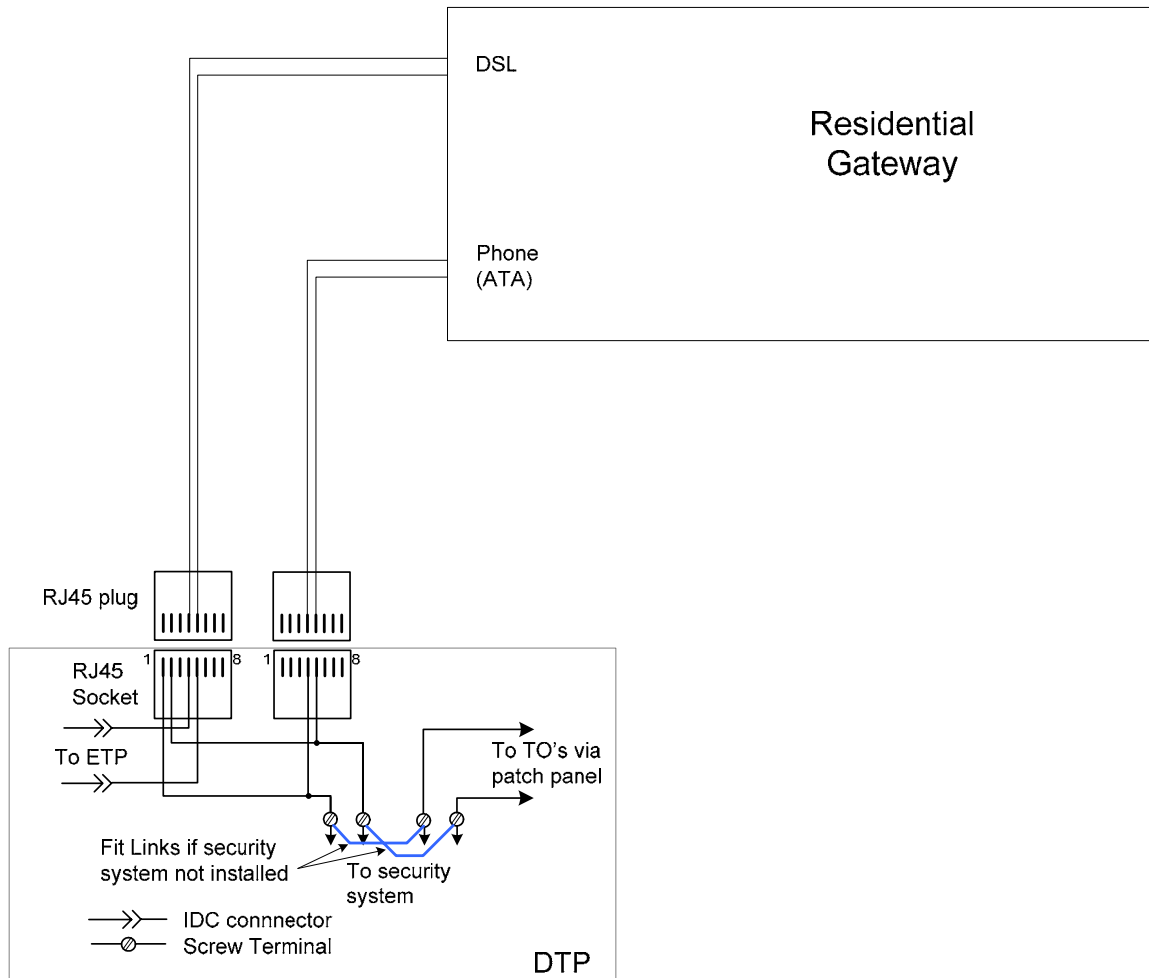

Connection of a Residential Gateway to a DTP using two cables

Notes:

The Residential Gateway will also have Ethernet Ports which can be patched directly to TO's or patched via a hub/router to TO's.

The RG must be located at the DTP, it cannot be located remotely at a TO.

4.3.4 Cabling termination hardware within the Home Distributor

Any purpose-designed termination hardware may be used, but that supplied by recognised telecommunications cabling industry manufacturers is strongly recommended. Similarly, the recommendations of such suppliers for the installation, testing, use and ongoing management of this hardware is to be followed.

4.3.5 Cross-connections

(1) The actual means of making cross-connections is not defined. Jumpers, patch cords, switches and other hardware (such as a router or home PABX system housed within the Home Distributor) may be used as the means of connecting between the various services and the TO's.

- *For most customers with relatively little technical knowledge, patch cords are the most suitable approach, as no special tooling is required and cross-connections are easily carried out as long as the various connection points are clearly marked.*

(2) For long-term reliability where patch cords are to be used, it is strongly recommended that these be factory-terminated and of such a length that there is plenty of flexibility for movement, but it is not necessary to coil up surplus within the Home Distributor. Flexible cords should preferably be used to ensure that subsequent movement during re-connection work will not result in failed connections.

- *While it may initially be cheaper to terminate appropriate short lengths of cable “on-site”, such connections can prove unreliable in the longer term. In particular, the use of solid conductor cable as patch cords often proves unreliable where the patch cords are subject to movement during the service life of the installation.*
- *Where cables or cords are “on-site” terminated, it is important that the correct type of plug and crimping tool is used. Plugs intended for use with flexible cords are not suitable for use on solid core cable, nor are those intended for solid core cable suitable for flexible cords.*

4.3.6 Hardware for other services within the Home Distributor

(1) The Home Distributor will also typically house a router for home Local Area Network (LAN) operation, along with its power supply, television distribution hardware (coaxial cables, amplifier, splitter and power supply), infra-red remote controls for the AV system, security system or medical alarm connections.

(2) There is no constraint on what hardware is fitted within the Distributor, as long as everything is consistent with a tidy and uncluttered installation that facilitates operation and servicing of the overall services, with no sources of electrical interference to those services.

(3) ADSL splitters are expected to be available for generic cabling applications. Where these are fitted within the Home Distributor, there is full flexibility to fit the associated ADSL modem within the same cabinet or connect it at any TO.

4.4 Cables and related hardware

(1) All cables, TO's and hardware used in wiring a residential customer's premises and intended for connection to the Telecom network shall be compliant with the relevant industry standards.

(2) Cable shall be 4-pair of Cat 5 or higher performance for both residential and commercial wiring, since this is now the recognised minimum “industry standard”. All such cable shall have nominal 0.5 mm diameter conductors and its sheath shall bear an industry-recognised certification mark and performance rating in accordance with international standards.

- *Telecom accepts that any cable so marked is equivalent to its Telepermit requirements, subject to (2) below. As such, it may be used for residential cabling installations connected to the Telecom network.*

(3) With Category 5 (and above) cable if the cable run is broken (no matter what type of Cat 5 cable) the Category 5 performance capability is lost. In order to maintain the performance the entire cable run must be replaced.

(4) Cable used for wiring outdoors shall be purpose made “external” cable.

- *Typical outdoor Cat 5 cables are either drycore water blocked (using water blocking yarns) or Gel filled cables and have solid (not stranded) conductors. “Buried” and “self supporting aerial” types are available.*

(5) Telecom regards the use of unshielded balanced pair cable (UTP) as standard practice, but shielded types (STP) may be used in conjunction with shielded sockets and other shielded components where shielding is the basis of a commercial design and all components are installed by suitably trained and skilled staff.

(6) This code of practice does not specifically cover requirements for screened cabling, which is not necessary for current Telecom-supplied services. Where screened wiring systems are supplied commercially, the supplier shall provide clear information on the installation practices needed to ensure system integrity and performance.

4.5 Telecommunications Outlets

4.5.1 Hardware type

(1) The socket assemblies used in TO’s shall meet Category 5 or higher performance requirements and be marked with the relevant Category rating.

- *At the time of writing, RJ45 TO’s and many individual items of cross-connection hardware are NOT subject to Telepermit requirements. However, it is required that any home distributor offered for commercial sale does hold a Telepermit and complies with Telecom specification PTC 225.*

(2) Any brand or model of RJ45 socket, whether assembled into individual modules with associated IDC connectors, or made up complete with faceplates, may be used as long as such sockets comply with a recognised industry standard and are marked accordingly.

- *Standard “Keystone” format socket assemblies are recommended where the installation is not wholly based on some proprietary socket system using other than keystone sockets.*

(3) Unshielded TO’s are regarded as standard practice, but shielded types may be used in conjunction with shielded cable and other shielded components where this is the basis of a commercial design and installed by suitable skilled staff.

(4) Where it is likely that subsequent jackpoint installation work will be carried out by customers not having the appropriate special insertion tools, TO’s with “tool-less” IDC terminations are recommended.

4.5.2 Telepermit requirements

RJ45 TO's are not currently subject to Telecom's Telepermit requirements, as these items, along with the Home Distributor and associated cabling, are not covered by Telecom's wiring maintenance service. Nevertheless, it is a requirement of Telecom's Standard Terms and Conditions for its network services that premises wiring is provided and installed in accordance with Telecom's Codes of Practice. Compliance with the requirements of this Code is thus regarded as a prerequisite for the provision of Telecom's services.

4.5.3 Labelling and identification

(1) Preferably all TO's should be individually labelled, with the same identification at the cable termination in the Home Distributor, so that both cable and TO termination can be clearly associated when connecting new services.

(2) Many faceplates and TO modules do not provide an actual label holder and it detracts from the overall appearance to mark the faceplates. It is recommended that either hardware with removable cover plates be used, such that markings can be made on the underlying switch plate; or that a simple convention be used to identify individual TO's on a dual or multi-way switch plate in association with a building layout plan.

- *For example, numbering all TO's from left to right or top to bottom in a consistent manner.*

5 REQUIREMENTS FOR ALL CABLING SYSTEMS

5.1 Safety Requirements

5.1.1 General

(1) Every care shall be taken that work is undertaken safely, especially where changes to existing installations involve work in dark ceilings or access into wall cavities often containing power cables and possibly gas pipes. Potential hazards shall be identified and located prior to starting each aspect of the work.

(2) In particular, the installer shall check for hazardous voltages before carrying out any work on premises wiring. Nevertheless, compliance with all relevant safety standards is required.

5.1.2 Hazardous Voltages

(1) Under normal conditions no hazardous voltages are applied by Telecom to any of its lines. Nevertheless, it is possible for lines to become hazardous at any time from earth potential rise, power distribution system faults, lightning activity, or contact with power wiring within the customer's own premises or equipment.

(2) Safe electrical industry working practices shall be followed. These include completion of all wiring connections before finally connecting to the line.

- *It is not normally necessary to touch bare conductors during installation and connection because of the extensive use of insulation displacement connectors (IDCs).*

- *This practice will also minimise the risk of shock from non-hazardous network voltages such as ringing, causing possible injury from the personal reaction to a shock, such as losing balance and falling.*

(3) In accordance with AS/NZS 3000, any metal cabinets used for the Home Distributor shall be earthed and LV cabling shall be enclosed in a separate compartment to that which houses the ELV or TNV cabling.

5.1.3 Connection of 230 V and ELV/TNV on same TO faceplate

(1) Under NO circumstances shall Low Voltage (LV e.g., 230 V) sockets, switches or modules be mounted on the same faceplate as TNV or ELV components (voltage levels at which telecommunications and data services operate).

- *The joint Australia/New Zealand Wiring Rules (AS/NZS 3000) require that all faceplates comply with AS/NZS 3112, clause 3.2 of which prohibits mixing of these voltage levels on the same faceplate.*

- *Standard 115 mm x 70 mm faceplates are now available with up to 6 apertures, catering for a wide range of modules intended to operate at various voltage levels. Such modular sockets are widely used for TO's and the various types of module can be physically located on a common*

faceplate. Nevertheless, clearances are reduced below acceptable levels and there is risk of 230 V contacts with the telecommunications cabling.

(2) There has been some confusion over the use of mechanical barriers between the two levels of voltage. Typically, rubber shrouds have been fitted over the telecommunications socket to provide segregation. This is no longer permitted.

5.2 Cabling system performance

(1) Generic home cabling uses essentially the same components as commercial building cabling to AS/NZS 3080, which is designed to provide the required performance with cable runs of up to 90 metres. In a home situation, such long cable runs are unlikely and, for most New Zealand homes, few run lengths are likely to be over 15 metres. This is particularly the case if the Home Distributor can be centrally located.

(2) In view of the short runs normally encountered, it can be expected that the full rated performance of the chosen components will be achieved without special measures being taken. However, the high frequency transmission performance of categorised cable is highly dependent upon the cable not being deformed prior to, during, or following installation. In view of this, accepted industry practices **MUST** be complied with. This includes the following mandatory points:-

- (a) During installation cable shall not be jerked or pulled such that the tension exceeds 110 N (approx 11 kg)
- (b) There shall be no kinks or twists in the cable;
- (c) Bend radius shall not be less than 6 times the diameter of the cable. (nominally no sharper than 25 mm);
- (d) Pairing shall be maintained as close as possible to the wire terminations (IDC connections); cable sheath removal is to be limited to 25mm maximum.
- (e) Cable sheaths shall not be crimped or distorted by clipping;

• (e) precludes the use of a wiring staple gun because of the variability of timber density and the possibility that the sheath will be crimped by a staple. Where additional support is required, preformed plastic saddles are recommended.

5.2.1 General Wiring Issues

(1) The following wiring practices and requirements apply specifically to UTP, STP and coaxial residential cabling, though the same principles also apply to many small business applications.

(2) Particular attention shall be given to the prevention and control of water entering cables through or along their sheaths, which is the dominant cause of wiring faults in typical New Zealand dwellings.

(3) This problem is likely to be more serious with generic cabling because of the closer pin spacing in RJ45 sockets and the unprotected design of some TO's that are available, especially where high frequencies are used for enhanced applications and service degradation rather than complete failure could occur.

(4) Two separate cables, clearly labelled at both ends, shall be run from the Home Distributor to each TO.

(5) Joints (or "splices") and tee connections shall NOT be made within these cable runs. However, it is permitted to terminate a cable at either end with an RJ45 plug designed for connecting solid conductors.

- *Once installed, the location of TO's is relatively inflexible. Moving an existing jackpoint or providing an additional one, would almost invariably require a new cable run back to the distribution point, because joints are not permitted.*

(6) All conductors of cables from TO's shall be terminated on either purpose-designed terminations or RJ45 plugs within the Home Distributor.

(7) At least 300 mm of cable shall be left slack in the wall cavity at both ends of a run following its termination. This should be passed back into the wall cavity to form a "drip loop" such that should any water contact the cable it will not run into the TO.

(8) All 8 conductors of each cable shall be terminated, ensuring that pairing is maintained and wire mapping is in accordance with clause 5.5.

(9) For new installations, even where only one line is initially required, two 4-pair cables shall be run from Home Distributor to the ETP (or ONT) with at least 1 m of slack at the ETP (or ONT) end.

- *With the possibility of multiple lines and other network services being supplied via fibre optic cable in the future, it is recommended that two Cat 5 cables be provided from the Home Distributor to the ETP location if it is likely to be difficult to provide a second cable in the future.*

(10) This Code is primarily concerned with the cabling of new homes. As such, the cabling is expected to be carried out at the pre-lining stage of the building. While this makes for easy access to the framing for drilling access holes and running the cable, it does bring the risk of the cables being damaged by other building operations or being obscured if no aperture is cut in the lining. This leads to the following recommendations:-

(a) To the maximum practicable extent, electrical and telecommunications cabling should be left until the main framing has been completed and weather-protected, and all water and/or gas piping is installed;

(b) As a general principle, TO's should be mounted at the same levels as 230 V power outlets so that any cabling obscured by subsequent wall lining operations can easily be retrieved. Marking the flush box locations on the floor (with the height of the flush box centreline above floor level

also marked if it is not at the usual level) eases retrieval and ensures that the cabling is not overlooked if it is accidentally obscured by lining material;

(c) Cat 5 and coaxial cable shall NOT be coiled up in the flush box, but be run past the flush box without unnecessary bending, to be pulled back when it is time to make the terminations.

(d) All cables shall be clearly label at both TO and Home Distributor ends.

5.2.2 Segregation of Services

(1) Telecommunications cables shall be installed with a permanent separation of at least 50 mm from mains power cables in all locations, except where the cables are separated by a rigid barrier.

- *To minimise the risk of electrical interference from mains and switching transients or interference generated by appliances, the recommended spacing is at least 300 mm wherever it is practicable to do so.*

(2) TO's and associated hardware shall not be fitted closer than a horizontal distance of 200 mm from any fitting on which mains voltage cables are terminated, unless separated by a rigidly fixed barrier. However, there are further restrictions on the use of such barriers, as detailed in clause 5.1.3.

(3) Complying barriers include wall linings, full depth framing in walls and substantially enclosed mounting boxes. Electrical flush mounting brackets and open type flush boxes are NOT substantially enclosed in the above context. Without a barrier, the minimum 200 mm horizontal separation applies to both sides of a wall unless the wall cavity exceeds 200 mm depth.

(4) To minimise the risk of noise by induction, telecommunications cable shall not be run closely spaced and parallel to wiring of other services. Where it is not practicable to completely avoid such parallel runs, any length where spacing is close to the minimum of 50 mm, shall not exceed 3 m.

(5) Telecommunications cables should cross LV cable at right angles, maintaining the necessary separation by means of securing or by an insulated barrier.

- *Cables should be secured by plastic saddles not by clipping or by stapling.*

(6) To avoid the risk of electrical hazard and noise caused by induction, wiring directly connected to the Telecom network shall only have Telepermitted equipment and hardware connected to it.

5.2.3 Wiring under Floors

(1) Cable shall be run clear of potentially wet surfaces, such as the ground, along areas at the bottom of outside walls, bathrooms, showers, water tanks, laundries, and any other areas where unintended water leakage or dampness may occur.

(2) Connections to cables shall be made only in readily accessible locations and using purpose-designed terminating hardware.

(3) The cable shall be secured at changes of direction and at intervals sufficient to prevent undue sag and potential contact with subsequent groundwork or snagging during other under-floor operations.

- *Closely spaced clipping along timber should be avoided, unless this is necessary for appearance purposes when the cable is exposed to regular view.*
- *Cables should be secured with plastic saddles not by clipping or stapling.*

5.2.4 Wiring above Ceilings and in Walls

(1) Cables in ceilings and wall cavities shall be segregated from power cables in accordance with clause 5.2.2.

(2) Cables in ceilings shall be routed clear of areas where potential damage may occur, such as areas used for storage, or around chimneys, flues, heating ducts, water tanks and plumbing.

- *Cables should be routed along timber above the ceiling joists wherever possible, to avoid exposure to any water retained by the thermal insulation used between the joists.*
- *Cables above cathedral ceilings and horizontal runs in outside wall cavities should be avoided wherever it is practicable to do so.*

(3) In any roof areas where the height exceeds 600 mm, cable shall be laid below or clear of surfaces likely to be stood or knelt on, and shall be secured to prevent snagging during later operations.

- *Cables should be secured with plastic saddles not by clipping or staples.*

(4) Cables shall not be clipped in wall cavities or other inaccessible areas.

(5) Connections to cables shall be made only in readily accessible locations and using purpose-designed terminating hardware.

5.2.5 Wiring Within or Beside Concrete Structures

(1) Cables shall not be laid direct into concrete walls, floors or ceilings. Where it is necessary for cabling to pass through or be carried within a concrete structure, it shall be housed within a rigid plastic pipe. Any such pipes shall be laid on a slope such that any water running down external walls does not run into the building. The installation shall facilitate later removal and replacement of the cables, if required.

(2) Internal building cable shall not make direct contact with concrete surfaces, particularly those of outside walls and ground retaining walls. Where exposed surface wiring cannot be avoided, separation from the concrete shall be provided by enclosing the cable in conduit or Trunking, or by securing it to a timber batten with plastic saddles, not by clipping.

5.2.6 Surface Wiring

(1) As a matter of good trade practice, surface wiring should be limited to those few situations where there is no other option. Since this Code of Practice is intended primarily for new homes, the customer's requirements should be included in building plans, and there should be little need for surface wiring.

(2) In particular, surface wiring shall be avoided in areas subject to potential damage, including within 50 mm of floors. Wherever possible, surface cables shall be protected from inadvertent physical damage by running them along the edges of skirting boards, Scotia's, architraves, or window and door frames.

(3) Cables shall be secured at changes of direction and also at intervals not exceeding 300 mm in areas where they may be disturbed. This includes the interiors of cupboards, wardrobes, and the like.

- *Cables should be secured with plastic saddles not by clipping or by stapling.*

5.2.7 Wiring Between Buildings on Same Site

(1) Where the cable can be run entirely within a fully enclosed access-way, it is deemed to be inside wiring.

(2) Inside cable may be run in conduit only where the cable run is relatively short, above ground, sheltered from weather, and the conduit can be supported over the full distance on a convenient surface. Such installation shall provide for later removal and replacement of the cable, if required.

(3) External cable, as specified in clause 5.2.2, shall be used in above-ground locations exposed to weather, and shall be attached to a structural surface or adequately supported by a self contained or separate bearer wire. The route shall be clear of potential hazards and potential damage. Any poles used shall adequately support a ladder to facilitate maintenance.

(4) To facilitate later removal and replacement of the cable, if required, external cable used for underground runs shall be installed in a buried pipe which extends at least 300 mm above the floor within an indoor location at each end.

5.2.8 Wiring to Equipment Exposed to the Weather

(1) Where equipment and its associated cabling and wiring are exposed to the weather, all such components shall be of a design suitable for this purpose.

(2) Standard TO's shall not be located outdoors unless housed in industry standard housings of the appropriate IP rating.

- *The need for external TO's has, in any case, been superseded by cordless telephones and WiFi for data/LAN services.*

5.2.9 Cleanliness

(1) All cabling hardware shall be kept clean during installation, avoiding contact with dirty hands, dust from building operations or other contamination likely to cause premature corrosion.

(2) Following their termination, RJ 45 sockets shall be protected from dust entry, paint, plaster, etc, until building operations are completed.

5.2.10 Water protection

(1) In order to prevent water transported on or within the sheath from reaching the associated terminations and hardware, cables shall enter terminating hardware enclosures either:

- a. from below the enclosure; or
- b. only with a drip loop provided if it is not practicable to enter from below the enclosure.

- *For surface mounting boxes, this requires cable entry at a bottom corner of the rear. For flush mounting boxes, cable entry needs to be from the bottom.*

- *While it is obviously not intended, during the life of a building leaks in roofs or wall cladding, around windows, etc, as well as pipe leaks within the building, can all lead to water coming into contact with cabling. In some cases, the cable sheath may absorb moisture or provide a path along which it can travel into the TO and result in service failure due to corrosion. This has proved to be a significant cause of service outages in New Zealand's generally damp climate.*

5.3 Cross-connections and commoning of TO's

(1) For telephony and voiceband data services, the Home Distributor will usually incorporate some form of commoning hardware to allow several TO's to access the line concerned. There is no limit on the number of TO's that may be connected to the same line.

(2) However, it should be noted that the total number of CPE items which will operate correctly on a single analogue line is limited by the sum of the Ringing Numbers (RN) assigned to each CPE item connected to that line. Reliable ringing detection is achieved by ensuring the sum of the individual CPE "RN" does not exceed five, refer PTC200 section 7.6.

5.4 Connection of line-grabbing devices

(1) Fixed wiring of CPE is limited to those devices, such as security and medical alarms, whose primary purpose would be defeated, if connected at any general purpose TO. Line grabbing CPE, such as security diallers, shall be directly connected at the Home Distributor. Such connections may be via jumpers, patch cords or direct hard-wired connections.

- *For easy disconnection and reconnection in the event of a service problem, the RJ31X "switched" version of the RJ45 may be used. This automatically by-passes the alarm device if its*

plug is removed. Such connections are to be made on the customer's side of a central ADSL splitter where one is fitted in the Home Distributor.

5.5 Connection of Broadband services

(1) With a Home Distributor and star wiring throughout the premises, the Home Distributor can be used to house an ADSL splitter such that:-

- (a) any TO can be used to connect the ADSL modem; or preferably
- (b) the Home Distributor houses a modem with an integral router or the modem and a separate multi-port router, such that any TO's can be used to connect PC's and other equipment with an Ethernet interface.

(2) Where a central ADSL splitter is mounted within the customer's premises, it shall be of a Telepermitted type and shall be connected on the network side of all other premises cabling, including line-grabbing devices.

5.6 Mounting Hardware

(1) Where the TO is not designed to provide a reasonable level of protection against dust and dirt within the wall cavity, boxes used for mounting TO's and other terminating hardware should preferably be of substantially enclosed construction.

- *The sides, top and bottom of surface mounting type boxes should be continuous with provision for cable entry at the lower rear.*
- *The sides, rear and top of flush mounting types should preferably be continuous except for small holes, and the bottom should contain a cable entry hole not exceeding 30 mm diameter.*

(2) TO mounting hardware shall be securely fixed in position. If not screwed to timber framing, it shall be rigidly fixed to wallboard using suitable fasteners.

5.7 Faceplates and socket orientation

(1) Standard 230 V style rectangular faceplates matching those of the other electrical fittings in the home are recommended for aesthetic reasons. Those providing for separate modules to be fitted facilitate later replacement of any faulty or damaged modules without replacement of the complete assembly.

(2) Faceplates may be installed "horizontally" (landscape) or "vertically" (portrait), but in all cases the RJ45 socket shall be oriented such that the plug latch will be on the underside. This ensures that the contact springs are at the top of the socket and less susceptible to dust or dirt settling on them.

(3) Dual RJ45 TO's should be installed as the standard provision at each location. A three-aperture modular faceplate allows for the fitting of a coaxial "F" connector at any locations where a television set is likely to be used.

(4) It is strongly recommended that the dual RJ45's are not connected to a single Cat 5 cable. For full flexibility with future applications, each needs a separate cable.

5.8 Cable termination

(1) Wires shall be terminated on TO's, cables, commoning and cross-connect facilities only with the correct purpose-designed tool for the hardware concerned.

(2) All four pairs are to be correctly terminated; the wires of a pair shall be kept together and shall be untwisted to the minimum practicable extent consistent with sufficient length for terminating them. For Cat 5, the untwisted length shall not exceed 13 mm.

(3) The following mandatory requirements apply to wiring terminations in insulation displacement connectors:-

- (a) Only strip as much sheath from the cable as is required to terminate the paired conductors (typically no more than 12 mm), leaving the sheath intact as close as practicable to the actual terminations.
- (b) Insulated wires shall be inserted into the slots with the insulation undamaged in the vicinity of the actual connection. They shall be inserted individually from the correct direction – i.e., from the side opposite the housing shoulder for Krone type IDCs – before individually pushing each wire home.
- (c) No attempt shall be made to terminate wires of types other than those which are specified for telecommunications wiring.

(3) For shielded cable, whether foil or screened, the appropriate type of terminating hardware shall be used in accordance with the manufacturer's recommendations.

5.9 Wire mapping

(1) There are two standard pin-out options available, commonly referred to as "568A" and "568B". The 568A option is regarded as the preferred option in Australia and New Zealand. This option should be used unless there is some specific reason why this is not practicable.

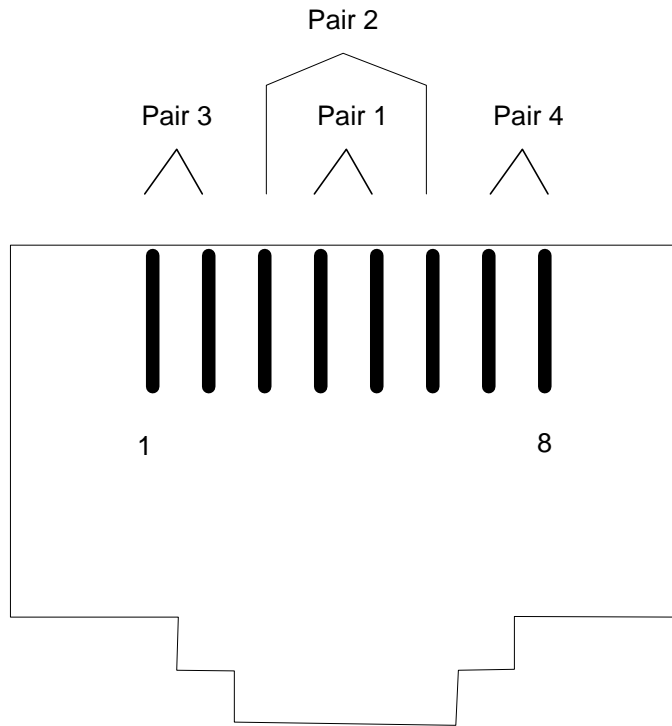

RJ45 Contact Spring Numbering
viewed from front

NOTE: Actual wire terminations on IDC strips will vary from one manufacturer to another

(2) Note that many RJ45's will show both options usually marked simply as "A" and "B", with the relevant colours shown against terminals and no apparent references to the actual pins connected. The wire to pin allocation for 568A is as follows:-

Pair Number	Insulation Colours	Abbreviations	TO Pin Connection
Pair 1	White – Blue	WH – BL	5
	Blue	BL	4
Pair 2	White – Orange	WH – OR	3
	Orange	OR	6
Pair 3	White – Green	WH – GR	1
	Green	GR	2
Pair 4	White – Brown	WH – BR	7
	Brown	BR	8

Pin-out arrangements for the 568A wiring option

(3) Whether the 568A or 568B option is used, the same option shall apply throughout the installation.

(4) To avoid problems when additions are made, where the 568B option is used, this shall be clearly marked on the Home Distributor and in any user instructions or cable records.

5.10 Child safety precautions

(1) Unlike telephone jackpoints using the standard Telecom socket (based on UK practice) which are always fitted with a shutter, most types of RJ45 are left open unless a plug has been inserted. The RJ45 aperture is large enough for a standard test finger to make contact with the centre contact pins, which operate at TNV3 when the socket terminates a public exchange line. This is not of concern in commercial premises, where this type of socket has been used for many years and only adults are usually present.

- *TNV3 is fully defined in IEC Standards but, for the purposes of this document, it can be explained as “normally operating at less than 42.4 V peak or 60 V dc, but with occasional ringing voltages of up to 90 V ac and potentially subject to over voltages from time to time”. These over voltages could be produced by contact with mains power or by lightning surges, both of which are very rare events in New Zealand.*

(2) TO's are normally mounted about 300 mm above floor level. For home use, where small children are present, there is the possibility of a child inserting a finger into an open socket. It must be stressed that TNV3 is NOT regarded as “hazardous”, even during short periods of ringing, and any skin contact is limited to the small surface of the contact pins. As such, there is no risk of electric shock, but a child could receive a fright should a finger or some other electrically conductive object be poked into a socket while ringing voltage is applied.

(3) It is recommended that in any circumstances where no CPE is connected, the jackpoint is directly connected to the public network and likely to be “poked” by a small child, either a shuttered socket is used or a “dummy” plug is inserted to close off the aperture.

- *Note that this warning and recommendation ONLY applies where the socket is connected to the public network. Many TO's are likely to be unallocated, while others will be connected to internal services operating at Extra Low Voltage. In both cases, it is completely safe to touch the bare contact pins.*

(4) This matter has been raised with the Energy Safety Service, which has considered the implications of children touching the pins and agreed that there is no risk of injury.

5.11 CPE connection to Telecom lines

5.11.1 Connection options

- (1) Almost all telephones and related CPE now in service and new equipment being offered for sale uses the 6-way plug to BS 6312 adopted by Telecom in 1983.
- (2) Where cabling is installed to this Code of Practice, it will generally be necessary to either use a suitable adapter to connect such equipment to the RJ45 TO's or have the line cords of CPE concerned re-terminated with RJ45 plugs. This decision is left to the customer.
- (3) Where any older 3-wire connected telephones are still in use, these will require a "mastering" adapter with integral 1 microfarad capacitor to provide their ringing function.
- (4) Safety is assured only for CPE bearing the appropriate Telepermit label. Specific earthing and isolation requirements apply to mains powered CPE and separate power supplies. Only Telepermitted equipment may be lawfully connected to the Telecom network.

5.11.2 Series-connected CPE

- (1) While it is preferred that those TO's connected to an analogue line are directly connected via the Home Distributor, it is acceptable for some TO's and their associated wiring to be controlled by CPE connected on the line side of the TO's.

- *A typical example would be a home PBX system. This could conveniently be located within or close to the Home Distributor.*

- (2) Where possible, associated CPE should be directly plugged into the series CPE that controls it, so that users are aware of the arrangement should they be unable to initiate or answer a call.

- *Typical examples are a ringing decoder or a caller display adjunct unit to which the associated CPE is connected. If a call cannot be made via the series device, it can easily be disconnected for test purposes.*

5.12 Earthing

- (1) There is no provision for an earth connection to CPE via TO's. CPE is deliberately isolated from earth as a safety measure.

6 COAXIAL AND SCREENED CABLING

6.1 General

(1) Coaxial cabling for television and other radio frequency applications is not directly or indirectly connected to Telecom's network. As such, it is not a matter for Telecom to define how or what should be done. However, when any consideration is given to the cabling of new homes, the needs for reticulating free to air and satellite television should not be overlooked. With a modern home, the UTP and coaxial cabling can form an overall "integrated network" linking the various items of equipment, such that more or less any service is available at any location - as long as suitable remote control facilities have also been provided.

(2) General information on television cabling is covered in the Appendices, as explained below. It is recommended that specialist contractors be approached for more detailed information on the design of television distribution and remote control facilities.

(3) It is recommended that dual RJ45 TO's be provided at each proposed television set location for either connecting the SKY decoder or, in future, the equipment needed for television delivery over Ethernet. The most convenient approach in a new home is to make use of a three-way faceplate to house an "F-connector" between the two RJ45's.

- *This is easily accomplished with the various makes and styles of modular faceplates used for electrical installations. These replaceable modules also avoid the need to replace a complete assembly should one or other parts fail in service.*

(4) High performance 4-pair screened cable using screened TO's and other components rated at Cat 6 or Cat 7, may be used for television, video and audio distribution, as well as for data and telephony. Such screened cable and hardware is not generally supported by Telecom, but is available from some suppliers in New Zealand. Where these components are used, the relevant manufacturer's recommendations are to be followed.

6.2 SKY Digital service

(1) Further information on specific requirements set by SKY Network Television Ltd for cabling between a satellite dish and their decoder(s) is given in Appendix No. 3 to this Code of Practice. These requirements extend to the connectors used for the antenna feed.

- *The signal bandwidth used by SKY for its satellite service extends to 2.2 GHz, well above the UHF Television band. As such, cable, splitters, amplifiers and connectors needs to be rated for the higher frequencies used.*

(2) Consideration needs to be given to the likely placement of a decoder and whether or not it might be re-located in the future. Where there are potentially multiple locations, the use of dual RJ45 TO's, SKY-approved cables and two or

more SKY-approved "F-connectors" at all of these locations should be considered.

6.3 VHF/UHF Television services

(1) The New Zealand UHF band extends to 806 MHz and most good quality coaxial cable and general purpose "F-type" coaxial connectors are suitable for these frequencies.

(2) General information on television distribution via coaxial cable is given in Appendix No. 6.

6.4 AV and audio distribution

These services can be distributed around the home via coaxial, STP and UTP cable. Where the UTP cable is used, suitable connectors are required to adapt between the equipment concerned and the RJ45 TO. Since these items are not part of the fixed cabling, they are not covered by this Code of Practice.

6.5 Remote control facilities

The infrared remote control units used with most television and audio/video products are usually restricted to operation in the same room as the associated equipment. However, there are various means of providing for control from any location in the home. Both wireless relay devices and equipment for passing the control signals over coaxial or UTP cable are available. Since these items are not part of the fixed cabling, they are not covered by this Code of Practice.

6.6 Security cameras

These too can be cabled over both coaxial and UTP cable with the appropriate connectors. With suitable modulators the signals from the security cameras can be mixed with the other television services such that they are allocated to otherwise unused UHF channels and can be monitored via any television set on the home network and set to those channels.

7 INSTALLATION TESTING

7.1 Installer's obligations

(1) Before handing any new or altered wiring installation work over to the customer, such work shall be thoroughly tested to ensure that all wiring is correctly terminated in accordance with the type of jackpoint and termination hardware used. Wiring capable of being connected to Telecom's network shall be free of short-circuits, contacts with other conductors, and discontinuities. Pair integrity shall be maintained. Any defective cables shall be replaced and termination faults remedied before handover to the customer.

(2) Where problems arise, the installer shall ensure that all necessary remedial action is taken.

- *In view of this Code of Practice being aimed primarily at new home cabling installations, the Consumer Guarantees Act 1986 applies as to the installer ensuring that the installation is suitable for its intended purpose.*

7.2 Testing and Certification

(1) As a basic minimum, the installer shall test the completed links from each TO to the Home Distributor termination to confirm that the wire mapping is correct and that there are no contacts, crossed or split pairs or disconnections.

- *This is particularly important where the home has been generously provisioned with TO's, many of which may not actually be used for some time and faults will only be apparent to the customer when the TO is finally brought into service.*
- *This minimum testing is based on the assumption that correctly installed cable in homes will involve relatively few runs, most of which would be typically less than 15 m. Such short runs of cable are fairly certain to meet the required transmission performance. Full Level 2 testing, using a Time Domain Reflectometer (TDR), may be preferred by those installers or equipment suppliers providing an extended warranty, but TDR testing is not generally reliable on runs of less than 15 m. Minimum 15 m lengths may be recommended in such cases, with the spare cable left coiled in the ceiling space.*

(2) A suitable test instrument shall be used, such as an "SLT3", which comes in two parts. One part is connected at each end of a TO - Home Distributor link. This confirms wire mapping and checks for contacts or disconnections.

- *Low cost simple LAN cable testers with these capabilities are now quite widely available from around \$50.*

(3) Following testing and any necessary remedial action, the installer shall provide a written statement of compliance in accordance with the format shown in Appendix No. 1, showing the extent of the testing carried out, the name and associated company of the person conducting those tests and the date on which the installation was deemed to be compliant.

- *It is recommended that this statement of compliance be housed within the Home Distributor cabinet.*

7.3 Testing and Certification of coaxial connections

(1) It is recommended that all coaxial connections at outlets and within the Home Distributor are also tested for continuity, for ensuring there are no contacts between the screen and the central conductors, and that there are no unwanted earth loops.

(2) As explained in Section 6, coaxial cabling is not a matter for Telecom involvement, but the effectiveness and suitability for its intended purpose of any home installation is subject to the requirements of the Consumer Guarantees Act. As such, the installer needs to ensure there are no wiring or connection faults that will later impact on the customer's service.

8 INSTALLATION RECORDS AND MAINTENANCE SUPPORT

8.1 Cabling Management

(1) The installer shall provide written advice to the end customer on the basic management and operation of the cabling system. Such advice may be in the form of standard information published by the supplier of the cabling hardware or a customer-specific document drawn up by the installer.

(2) In particular, the user information shall include:-

- (a) a simple means of indicating the terminations within the Home Distributor that correspond with each TO and clearly explain the means of making and recording the necessary cross-connections; and
- (b) a clear warning to the effect that the installation is not eligible for maintenance by Telecom under its Residential Wiring Maintenance Service and that the customer concerned is not to subscribe to this service:
- (c) a clear explanation of how to use the disconnect house wiring from the network and test house wiring functions.

(3) The overall aim is that information and installation records prepared by the installer should be such that a typical “customer” can understand how the system is set up and have a reasonable chance of being able to make cross-connections when service “add, moves or changes” are needed.

8.2 Support

(1) At present, Telecom does not offer routine maintenance support for generic cabling installations, and this class of wiring is excluded from Telecom’s residential wiring maintenance service. In accordance with consumer protection legislation, installers shall warn their customers of this point and be prepared to provide after sales support and ongoing maintenance.

(2) Unless it is completely clear from inspection of the Home Distributor cabling and cross-connections, all generic cabling installations shall be provided with clear installation instructions and facilities for recording the service connected to each jackpoint.

- *The use of appropriate colour coding schemes and clear labelling of all components may be such as to obviate the need for a “paper record”, especially where the installation is small and few services are connected. The aim is to ensure that the information available is such that an average customer or service person will not have undue difficulty in determining what service is connected to any TO.*

TO/HD DESIGNATION	Connected to	Service	Comments
1	Line 2 telephone		Family phone line
2			
3	Line 1 telephone		Home business line
4	Colour Laser printer		
5	Router Port 1	Home LAN	
6	ADSL Modem	JetStream	
7			
8			
9	Router Port 2	Home LAN	
10			
11			
12			
13			
14			
15			
16	Line 2 telephone		DECT base station
17			
18			
19			
20			
21			
22			
23			
24			
25	Line 2 telephone		Family phone line
26	Router Port 3	Home LAN	
27			
28	Router Port 4	Home LAN	
29			
30			
Coaxial 1	SKY antenna		
Coaxial 2	Free to Air antenna		
Coaxial 3	Infra-red target for Video		
Coaxial 4	VCR AV input		
Coaxial 5	Bedroom TV		
Coaxial 6			
Coaxial 7	Front security camera		
Coaxial 8	Rear security camera		
Coaxial 9			
Coaxial 10			

A typical example of a cable record is where every TO cable is terminated on an RJ45 socket using the same designation within the Home Distributor. The service allocations and TO numbers relate to the floor layout shown after clause 3.2.3. Coaxial outlets and locations are not defined and are shown only as “reminders”.

8.3 Installation records

(1) The installer shall provide a basic record system relevant to the cabling and hardware installed.

(2) The actual format of this record is left to the installer to agree with the customer. However, it is suggested that this be based on a floor plan of the premises showing TO locations and identification details for each TO as shown in the figure at the end of Section 3.

- *With a simple numbering system used for the TO's, these numbers should align with the termination numbers used at the Home Distributor end of the TO cables. Any record is then a simple case of stating what services are connected at each TO and showing any TO that is not in current use. This avoids the risk of customers thinking a TO is faulty when it is simply not connected at the TO.*

(3) An example of a simple cable record is shown above. Note that this record can become far more complicated if the TO and Home Distributor ends have different identification numbers or designations.

9 SPECIAL SITUATIONS

9.1.1 Door and Gate entry control systems for individual customers

(1) Special requirements apply to any systems which make use of the premises wiring to carry entry authorisation or gate control signals.

- *Typically, such systems use a telephone, located at the gate or outside door, which directly rings the internal telephones. After ensuring that the caller is genuine, the occupant simply enters a code via the telephone keypad to unlock the gate or door.*

(2) All gate and door entry control system equipment intended to be connected to the Telecom network shall be Telepermitted and be labelled accordingly.

- *This not only ensures that the equipment is compatible with the Telecom network and other equipment connected to the same line, but also that it is electrically safe.*

(3) All wiring shall comply with this Code of Practice.

(4) Gate entry systems shall be connected on the customer's side of the network demarcation point. It is **NOT** permissible to divert the network lead-in cable between the Telecom network cable terminal on the road frontage and the Telecom network demarcation point at the building entry point.

- *Where a gate entry system is to be installed for a new building, especially if it has a long driveway, the recommended approach is to co-ordinate the lead-in and gate entry cable installation with other building services work. This allows the several services concerned to share the lead-in cable trench, which is paid for by the customer. The gate control installation contractor can then run the necessary control and communication wiring before the trench is closed.*

9.1.2 Door and Gate entry control systems for two or more customers

(1) Where the door or gate entry control system is common to more than one Telecom customer, it may be necessary to divert those customers' lines into the entry system in order for those customers to jointly use the system. Suitable arrangements need to be put in place to ensure that such cable diversion does not impact on the reliability of Telecom services for those customers or on Telecom's ability to overcome any faults that arise in the diverted cabling.

- *This arrangement may arise at such locations as blocks of flats or retirement villages housing a number of individual customers, where each customer has independent control of the door or gate security.*

(2) Customers' lines shall not be diverted into such systems without the express authority of Telecom and the formal agreement of all the customers concerned.

(3) All gate and door entry control system equipment intended to be connected to the Telecom network shall be Telepermitted. In addition, special contractual conditions will apply to the grant of the Telepermit as regards the cabling

arrangements, ongoing maintenance by the control system contractor and clear demarcation between that party's responsibilities and those of Telecom.

- *The suppliers of such systems should contact Access Standards for further details, as these are outside the scope of this Code of Practice.*

APPENDIX No. 1

COMPLETION FORM FOR HOMES WITH GENERIC CABLING

(Please print details below and leave a copy of this completed form in the Home Distributor)

Customer's address

.....
.....

Installer Details

Contact Details

Surname

Business phone Number.

Given names

(optional)

Business address

Date work completed

.....
.....

Employer (where applicable)

Name of Company

Business address

Telephone No.

.....
.....

Description of work carried out

.....
.....
...
.....
.....
...
.....
...

Certification

I certify that all the above work was carried out by me or under my supervision and that this work has been done in accordance with Telecom's Code of Practice, PTC 106, and has been tested to ensure the correct termination of all fixed wiring.

Signed

Date



APPENDIX No. 2

SPECIAL REQUIREMENTS FOR HOMES CONNECTED VIA TELECOM'S FIBRE NETWORK

A2.1. INTRODUCTION

(1) Telecom's "Fibre to the Home" is only one example of the changes that have arisen in recent years. It is important that occupants of the homes concerned will be able to make use of the many future services that are expected to be offered via the fibre without being restricted by a sub-standard cabling installation.

Generic cabling, as covered in this Code of Practice is regarded as mandatory for new homes connected to the Telecom network via fibre.

(2) All requirements of this Code of Practice apply to homes connected via fibre.

(3) However, network connection via fibre results in additional special requirements, as detailed below:-

A2.2 TELECOM-PROVIDED COMPONENTS

The items listed in clause A1.2 are supplied by Telecom as an integral part of the trial and remain in Telecom ownership.

A2.2.1 Fibre and copper lead-ins and pipe

(1) For the purposes of the initial trial, Telecom will provide both a conventional copper cable lead-in and a fibre lead-in.

(2) These cables run within a plastic pipe supplied by Telecom.

• *This pipe is laid in a trench provided by the customer or building contractor from the designated point on the street frontage to a suitable point on the external wall of each building concerned.*

A2.2.2 Fibre Network termination or "ONT"

(1) Telecom will provide a new item of equipment known as an "Optical Network Termination" or "ONT". This "weatherproof box" is usually mounted on the outside of the building at about the same level as the electricity company meter board. As both services will often share the same trench between the street and the home, the ONT will generally mount alongside the meter cabinet.

(2) It is expected that some homes may have the ONT installed within the building at a location agreed between the building contractor and Telecom. The fibre cable must be handled carefully to avoid any sharp bending and a suitable route needs to be agreed between the entry point and the selected ONT location.

A2.2.3 ONT Power

(1) Associated with the ONT is a separate power supply unit, which houses service monitoring facilities and an optional back-up battery providing for several

hours operation of the ONT and some services in the event of a 230 V mains supply interruption.

(2) It is recommended that the ONT power supply be mounted on the inside wall of the building close to the location of the ONT, preferably directly beside it where the ONT is mounted internally, or on the inside wall directly against the ONT where this is mounted on the outer wall of the building.

(3) The chosen location should be dry and clear of any sinks, tubs, etc, and where the unit is unlikely to be knocked or damaged. It is recommended that it be mounted at no less than 1200 mm above floor level. To ensure there is good air circulation around it, the power unit is not to be fitted in a cupboard or other enclosure.

A2.2.4 Power and alarm cable

A special cable must be run between the power supply and the ONT. This will be provided and, in most cases, installed by Telecom. The maximum permissible cable length is 30 m, but it is preferred the power supply be mounted close to the ONT, as explained above.

A2.3 CUSTOMER-PROVIDED COMPONENTS

The customer or any party designated to act on the customer's behalf, such as the building contractor, is required to provide the following items:

A2.3.1 Trenching for the network lead-in

Details are given in clause

A2.3.2 230 V power outlet for ONT power supply

A 230 V outlet, used solely for ONT power supply unit, shall be provided within no more than 2 metres of the proposed location of the power supply and, preferably within 500 mm.

- *Mounting the power supply close to the 230 V power socket will avoid the need for long power cords.*

A2.3.3 Home Distributor

(1) The Home Distributor used for fibre-fed homes is required to meet the same requirements as are described in the main body of this Code of Practice.

A2.3.4 Cables from ONT to Home Distributor

(1) Two Cat 5-rated cables shall be connected between the ONT and the home distributor.

- *One cable supports POTS services, which use the copper lead-in. The second cable carries those services delivered over the fibre. In the future they will also provide security in case one cable should be damaged and otherwise need replacement during the life of the home.*

(2) There should be at least 300 mm separation between the two cables over the majority of the run to ensure that any subsequent action causing damage does not affect both cables. This is especially necessary if access to these cables is no longer possible following lining of the building framing.

A2.3.5 Customer Premises Equipment (CPE)

The equipment supplied by each customer for connection to the Telecom network, including all telephony devices, modems, fax machine, alarm dialler, etc, are termed "Customer Premises Equipment" (CPE). Such equipment is subject to Telecom's Telepermit system, which confirms their compatibility with the network.

APPENDIX No. 3

PROVISION FOR SKY DIGITAL SERVICES

A3.1 Introduction

(1) Generic cabling is intended to support a wide range of services, combining conventional telephony and data services with entertainment, security, etc. It is expected that most new homes which install generic cabling systems will also make use of SKY Digital services. It is therefore worth giving consideration to how and where the Satellite Dish will be mounted and how it will be cabled in a manner that optimises the overall system performance for the end customer.

(2) Unfortunately, little consideration is usually given to these requirements at the architectural planning or construction stages and the SKY installer is only called in after the occupant moves into a new home. As a result, some compromises often have to be made by the installer because of difficulty in running the cables concerned after the building is completed.

(3) Needless to say, every building and location can offer different options. The main point is that by considering requirements as part of the basic building design, the overall installation can be flexible for future needs and meet aesthetic considerations. For example, by making sure the various cables will be concealed, that they are run to the most appropriate locations, and that the dish is not mounted in some way that the customer objects to.

A3.2 Architectural issues

(1) The 600 mm diameter grey Sky dish is relatively non-intrusive when mounted on a roof or a wall, but best performance is achieved in windy weather if the building structure provides a good firm fixing for the dish mount and it's bracing struts. Typical dish mounting hardware is designed to fix to a substantial timber backing in the building framing, but the widely-used New Zealand sheet metal tile roofing over narrow battens is not ideal for these mounts.

(2) In a completed home, the most common problem for SKY installers is the provision of cabling. The SKY installer has to run a coaxial cable (two recommended to cover future requirements) from the dish to the chosen location of the decoder, which is often on an inside wall of the lounge and not easily accessed. The SKY decoder also needs to connect to the telephone line for full operation of "pay per view" programmes. This not only requires a jackpoint close to the decoder, but also means that the SKY installer has to connect to the existing telephone wiring. Both requirements often demand some surface-mounted cabling inside the home, as well as cables secured to the outside of the building. Further problems arise if the SKY customer wants to re-locate the decoder for some reason.

- *Cables should be secured using plastic saddles not by clipping or by stapling.*

(3) At least part of the SKY cabling is separate from the basic generic cabling system, as SKY require specific types of coaxial cable to be installed between the dish and the decoder, or between decoders, where two or more are installed.

- *Unless one of the new dual channel PVR-type decoders ("MySKY") is used, additional decoders are required only where the customer wishes to view two or more SKY channels at the same time. Where the same SKY channel is to be viewed at different locations, the inter-connections can be made either at audio/video level using the generic cabling and TO's, or via co-axial cable operating in the UHF band.*

(4) To avoid the need for unsightly installations in a new home, it is recommended that provision for SKY digital service be considered as part of the initial planning of the building.

A3.3 Dish location considerations

(1) The Satellite Dish needs to face "Northwards" towards the satellite. The actual compass bearings vary according to the location, from 311 degrees in the West of the North Island to 325 degrees in the South-East of the South Island. Similarly, the elevation angle also varies with location from 47 degrees above horizontal in the North of the North Island to 35 degrees in the South of the South Island.

(2) The exact dish direction is not particularly critical from the initial location viewpoint, as the mounting system provides some adjustment flexibility to optimise the direction and elevation of the dish and the installer adjusts the dish as part of the service commissioning.

(3) Should the architect or builder wish to select a dish location and provide the cabling, there must be a clear line of sight between the dish location and the satellite. Any obstructions, such as buildings or trees will obviously govern whether a preferred location is feasible.

- *The architect may wish to ensure that the dish will be in an acceptable position as regards the overall appearance and, more importantly, avoid any risk that the subsequent installation could cause damage to the roof fabric or wall sheathing.*

(4) Whether wall or roof-mounted, it would be helpful to the installer if a firm backing could be provided. Typically, two 150 mm x 50 mm timbers fixed between the wall studs or rafters would provide an ideal backing.

- *SKY has a wide range of mounting options to fit more or less every situation. Location options for the dish mounting on a new home include:-*

on the roof (or a chimney, where one exists);

on a North-facing wall; or

on a South facing wall "looking over" the roof.

On any other wall that gives line of sight to the satellite

A3.4 Technical considerations

(1) SKY currently uses a single satellite (Optus B1), which is nearing the end of its operational life. A replacement satellite (Optus D1) will be launched to the same location in 2006. This replacement will have no impact on dish location.

(2) Some time around 2007 – 2008, it is expected that another satellite (Optus D2) will be launched. This will provide both back-up against failure of D1 and additional future services. D2 will use a wider bandwidth than the current B1 satellite, requiring modification of the dish electronics to provide switching between the two satellites or the use of two high performance cables between the dish and the decoder. Again, to avoid the need for additional cabling, it is recommended that two cables be installed initially.

A3.5 Pre-cabling

(1) SKY installers generally do the full installation after the home is completed and the customer subscribes to the service. The installer mounts and aligns the dish and cables between it and the decoder. SKY generally prefer to provide and retain ownership of the cable and dish, even though it is mounted on a customer's home and not usually recovered if the customer relinquishes service.

(2) With a home having generic cabling, there is the option to run the SKY coaxial cables from the dish to the Home Distributor and run additional SKY coaxial cables from the Home Distributor to other likely decoder locations within the home. This reduces the risk that additional cables would have to be run in the future.

(3) It is important to note that SKY has approved only a limited number of types of cable (listed in clause A3.7) and connectors (listed in clause A3.8). These cables are of proven service reliability and rated to perform at low loss over the full range of frequencies used between the down converter on the dish and the decoder (up to 2.25 GHz).

(4) It is recommended that two SKY-approved coaxial cables be run from the chosen dish location to the Home Distributor, leaving about 2 metres extra of each cable loosely coiled in the roof space. The ends of the cables should be sealed against moisture ingress with sufficient length protruding from the building for the installer to pull out as much as is needed.

(5) The same types of SKY-approved cable shall be used for any connections from the Home Distributor to likely decoder locations.

A3.6 Cable access way provision

(1) Another option is to provide a cable access path between the dish location and the Home Distributor or decoder location. This can be done with a suitable conduit and draw string.

A3.7 SKY-approved cable types

(1) To be acceptable for SKY digital purposes, ONLY the following types of cable may be used in the connection between the dish and the decoder:-

Belden (1828A-C) 3 GHz 75 Ohm RG6 Duo Sky Satellite YV43459-10 (Black) or YV43459-9 (White); or

TFC T10 TFC D32360 Maser RG6 Sky Digital Satellite 2.25 GHz approved (Black); or

TFC T10 TFC D32391 Maser RG6 Sky Digital Satellite 2.25 GHz approved (White).

(2) Where the cable is connected via a Home Distributor, it is recommended that the individual cables to the other TV outlets be carried out in these same types of cable. This provides maximum flexibility for re-locating a decoder in the future without the need for additional cabling.

(3) An amplifier may be required where the total length of cable run between the dish and the decoder exceeds 38 metres or splitters have been fitted. To assist in determining the total cable length, metre marks are stamped on the cable sheath at 2 m intervals.

A3.8 SKY-approved coaxial connectors

For the high frequencies used between the dish and the decoder, it is important that low loss connectors are used. SKY now specifies 360 degree taper or longitudinal F-type crimp connectors and no longer accepts hexagonal crimp F connectors. The types currently specified are:-

F-Con connectors marked "RG6 WRO" on the barrel; or

PPC CMP 6-OR BLUE F connectors.

A3.9 Warning

Failure to comply with the above SKY requirements will result in the dish to decoder cabling being rejected by the SKY installer.

APPENDIX No. 4

OPTIONAL INSTALLATION COMPONENTS FOR OTHER SERVICES

A4.1 General

- (1) There are many optional items which can be included with the fixed premises cabling. These services may, in some cases, share the above telecommunications wiring, but not actually connect to the Telecom network.
- (2) The following items may be supplied by the customer as components of the overall premises wiring installation. While they may not currently need to make use of any Telecom services concerned, Telecom recommends that customers consider including provision for these services within the overall wiring system.
- (3) Provided that such other services do not cause interference to Telecom's own services, Telecom does not set any conditions on what might be provided.

A4.2 TV/video distribution and control

(1) With virtually every home having free to air television and, often, paid services from Telecom and other operators, there is a need for distributing these services to television sets, recorders and players around the home. The home distributor provides an ideal point for cross-connecting these services, especially in the future when they are expected to be much more closely integrated with the home cabling system. At the present time, co-axial cables are generally used for these services.

(2) Many home customers subscribe to SKY Digital Television services. Each SKY set top unit (decoder) needs to be connected to the telephone network in order for customers to subscribe to "pay per view" services. This means that the more likely primary television set locations will need access to both the SKY cable from the roof or wall-mounted antenna dish and access to a TO connected to the Telecom network.

- See also Appendix 3 regarding provision for SKY Digital Services.

(3) The provision of broadband services and fibre to the home will, in due course, allow for delivery of video services over the Telecom network. For these services, the television set or a suitable set top unit will connect to an RJ45 TO.

(4) In view of the trend towards convergence of the various TV and Telecom network services, it is recommended that TO faceplates at likely television set locations provide for both television (co-axial cable termination) and TO's for Telecom network access. Any pre-wiring requirements should also include provision for the satellite dish and its connection to the Home Distributor.

A4.3 Audio distribution



As with video, some customers are keen to distribute audio around their homes. The cabling system is able to support these optional services.

A4.4 Home automation, monitoring and control

Another growing trend, although slow at this early stage, is home automation and remote control or monitoring of heating, lighting, etc. Such systems also need to connect to the outside world, usually via the telephone or data network.

A4.5 Security systems

These include basic security and medical alarm equipment, sensors, cameras, etc, not all of which may connect directly to the Telecom network, but need to be accessed from various points within the home.

A4.6 Centralised power supplies

The introduction of “Power over Ethernet” – based customer equipment will increase the flexibility of the wiring installation, not only as regards the ease of connection independent of a nearby 230 V outlet, but also provide the option of a high reliability (single or duplicated) dc power supply to the customer’s equipment. This avoids the risk of service disruption due to mains power surges and also provides for a battery back-up for many of those devices which must continue to be operational even when 230 V power is disrupted.

APPENDIX Number 5

POWER OVER ETHERNET

A5.1 Introduction

(1) The Institute of Electrical and Electronics Engineers (IEEE) Specification 802.3af covers "Power over Ethernet" (PoE), and the compatibility requirements for both power supplies and line-powered terminal equipment connected via unshielded twisted-pair wiring, patch cables, and RJ45 outlets.

(2) While it can be used with existing 4-pair UTP cable installations in most commercial buildings, it will apply only to newer homes with generic cabling.

(3) Terminal equipment, such as IP phones, wireless LAN access points, laptop computers and web or surveillance cameras, have traditionally required both power and network connections. It has thus been necessary to provide a 230 V outlet close to the jackpoint and, in many cases, a separate power pack for each device. Power over Ethernet can avoid both of these requirements. In time, it is expected that POE will become a "standard feature" for many types of terminal equipment.

(4) One of the main features of PoE is the adoption of - 48 V d.c. as the standard voltage to be used by all devices with PoE capability. As a result, the need for separate plug pack power supplies operating at different voltages and current ratings can also be avoided.

(5) Because PoE provides for point-to-multipoint power distribution like the data network itself, a common power supply can be located at the Home Distributor. Where necessary, this can be backed up by a 48 V battery to provide an uninterruptible power supply (UPS) for any critical devices on the LAN.

(6) PoE was originally intended for use with low-powered terminal devices in Ethernet cable networks, but it could also provide for a host of other low-power devices and appliances because it sets what could be regarded as the first truly international standard for small appliance powering. PoE defines the plug and socket and the pin-out, overcoming the present multiplicity of national standards for voltages and plug types. It could be used with such diverse low power appliances as electric shavers and broadcast radios or as a trickle charge source for higher powered devices like lap-top PC's. As a result, there may no longer be a need for business people to carry a variety of different plugs when travelling and the RJ45 jack could become the "universal low-power outlet".

A5.2 Power rating and compatibility

(1) Because it is designed to operate over 0.5 mm conductors, the current delivered to each outlet is limited to 350 milliamps in compliance with electrical wiring standards. Taking into account some power loss over the cable run, the total amount of continuous power that can be delivered to each outlet is limited to 13 watts. IP phones and wireless LAN access points typically consume up to 10 watts.

(2) The 48 V is fed over one pair, with an earthed return connection over a second pair. However, only terminal equipment with an authenticated PoE “electronic signature” will receive power, as the PoE power supply incorporates a detection mechanism to prevent sending power to non-compliant devices and potentially damaging them. As a result, legacy Ethernet devices and new PoE equipment can be safely mixed on a PoE cable network. Power flow is stopped within 10 milliseconds after a device is disconnected from the network, so a user changing devices on a port will not damage a second device which is not PoE compliant.

A5.3 Options

(1) The standard defines two options for power feeding; “end-span” and “mid-span”.

(a) End-span is used where the actual Ethernet switch incorporates PoE capability. New PoE end-span switches deliver data and power over the transmission pairs; 1 & 2 and 3 & 6 and are compatible with Gigabit Ethernet, which uses all four pairs. This option is used for new installations set up from the start to use PoE and it is recommended for new homes, as IP phones, wireless LAN access points and other such equipment will almost certainly be used within the next few years.

(b) Mid-span devices incorporate some form of patch panel and typically support between six and 24 channels. They are connected between legacy Ethernet switches and the PoE compliant devices. Each of the mid-span ports has an RJ-45 data input and data/power RJ-45 output connector. For 10/100 Mbit/s Ethernet, mid-span devices make use of the otherwise spare wire pairs 4 & 5 for the earth return and 7 & 8 to carry the - 48 Volts, while data is carried on pairs 1 & 2 and 3 & 6. The Mid-span option applies when upgrading an existing network to PoE, but not replacing the existing switches.

APPENDIX No 6

COAXIAL CABLING FOR BROADCAST TELEVISION, VIDEO, ETC

A6.1 Introduction

(1) While it is not of direct interest to Telecom, as its services will be delivered over the Cat 5 or better UTP cabling, coaxial cabling is briefly covered in this Appendix as it is important that any new home is wired for the full range of services likely to be required by the home owner or occupant. Obviously, coaxial cabling is also much easier to plan and install at the pre-lining stage and both types of cable can be run together where the outlets are co-located.

(2) Coaxial cabling requires a good deal of care and the proper tools for its termination. Similarly, some prior knowledge is needed to decide what components are required and how they should be assembled. The same applies when it comes to commissioning a system to ensure RF signal levels are within the optimum range.

(3) For optimum overall design and performance, the services of a specialist contractor may be needed. The following outlines some of the basic design and installation requirements for those carrying out their own cabling installation.

(4) Typical insertion loss characteristics of the components concerned are given for loss budget purposes only.

A6.2 TV/video Outlets

(1) Other than for SKY digital antenna feeds (See Appendix No. 3), industry standard “F” connectors are to be used for all connections at outlet points and on the various items of hardware. The connectors provide the necessary shielding to prevent both radiation of the signals within the cable or ingress of interference from other RF sources in the vicinity.

(2) As for RJ 45 TO's, outlets with “F” connectors are to be located only in dry areas and properly manufactured female “F” connectors are to be used at all outlets. These must be “captive” to prevent rotation when a male connector is screwed onto it.

(3) It is strongly recommended that wall outlets are not “home-made” by fitting straight connectors into holes drilled in faceplates. The general preference is a standard “F” connector module mounted in a three aperture faceplate, along with the two RJ 45 modules.

(4) As with RJ 45 modules, “F” connectors must not be mounted on the same wall plate as 230 V modules, outlets or switches.

A6.3 Cable types



- (1) Coaxial cable is available in dual shield, trishield and quadshield versions in both RG6 and RG11 types. RG11 is thicker and more rigid than RG6, which is generally quite suitable for the short cable runs involved in most homes.
- (2) As indicated in Appendix No. 3, SKY satellite cabling must be run only in SKY-approved RG6 cable. If it is likely that there will be a need for two or more SKY decoders or that a decoder is likely to be re-located from time to time, all such cable runs should use SKY-approved cable. Other types of RG6 cable are generally suitable for carrying all other VHF/UHF/video services. Where this limit is exceeded, an amplifier may be necessary.
- (3) Use good quality RG6 coaxial cable with insertion loss certified to be no greater than 18 dB/100 m at 750 MHz or, for long runs, RG11 coaxial cable with insertion loss certified to be no greater than 12 dB/100 m at 750 MHz. For both types of cable, Return Loss should be better than 18 dB over the range 5 – 500 MHz and better than 15 dB over the range 500 – 860 MHz, with screening better than 120 dB over the range 5 – 1000 MHz based on the GTEM test conditions.

A6.4 Cable installation

- (1) All coaxial cabling should be run with the same care as used for Cat 5 cabling, avoiding sharp bends, kinks or unnecessary pulling force.
- (2) Run a single RG6 coaxial cable between the Home Distributor and each outlet location. Allow for an extra 300 mm of RG6 cable to be stored in the wall cavity or roof space at both ends of each cable run.
- (3) Coaxial cable should not be subjected to sharp bends. Preferably keep all bends as shallow as practicable for each run. In no cases should bend radius be less than 40 mm.
- (4) With RG6 cable, the total run length between the signal source and the receiver should, as a general rule, not exceed 25 metres
- (5) Each cable is to be labelled at both ends, as for UTP cables.

A6.5 Connectors

- (1) 75 Ohm connectors with insertion loss of no greater than 0.1 dB over the range 5 – 500 MHz and no greater than 0.2 dB over the range 500 – 860 MHz should be used. These may be screw-connected, but crimp types are recommended as long as the correct crimping tools are used.

A6.6 Wall outlets

- (1) As for connectors, good quality types should be selected, with insertion loss no greater than 0.2 dB at 750 MHz. These should be “captive” in the faceplate to prevent their rotating when the cables are connected and screwed tight.

(2) Where it is desired that both free to air and pay television are simultaneously available at any location, or it is required that VCR, DVD or other video signals can be input at the same location, dual F connectors and two coaxial cables to the Home Distributor should be used.

A6.7 Cable termination

(1) Cables must be terminated in accordance with the manufacturer's instructions, using the appropriate tools where applicable. This is particularly important where tri- or quad-shielded cable is used. Generally, exactly 12 mm of sheath is first removed, 6 mm of screen and core insulate is then removed, leaving the centre conductor to act as the "centre pin" of the "F" connector. This is either required to protrude no less than 1.6 mm or more than 3 mm from the outer shell of the "F" connector.

(2) Ensure there is no part of the screen protruding and likely to contact the centre pin. Bad connections are a major cause of faults at customers' premises. Typical faults include the centre conductor being too long or too short; the screen making contact with the centre conductor, the dielectric not butting up against the base of the connector, the connectors being poorly crimped, or not the connection not being fully tightened.

(3) Cables at the Home Distributor will generally be fitted with a male "F" connector, with sufficient free length that they can be connected directly into the signal source, or into a splitter or splitter/amplifier. Those cables from unused outlets are left "hanging" within the Home Distributor.

(4) F connectors should neither be over-tightened nor left too loose. As a general guide, hand tighten and then turn about 0.5 – 1.0 mm (at the barrel of the connector) with a suitable spanner.

A6.8 Service distribution

(1) The same RF signals may be supplied to more than one outlet by means of a suitable splitter. Again, there are various options. A single splitter should be chosen with a sufficient number of outlets for the number of locations involved.

(2) To cover the full range of UHF TV band frequencies, the splitter is to be rated for operation at up to 860 MHz. Splitters introduce additional loss (typically 3.5 dB at 750 MHz for 2-way splitters and 6.5 dB for 3-way splitters). Where more than 3 outlet ports are required, an RF amplifier is necessary. This may be incorporated with a multi-outlet splitter into a single assembly.

(3) The splitter and amplifier are generally housed within the Home Distributor, along with an appropriate d.c. power supply and power supply inserter for the amplifier. The power inserter connects the d.c. voltage from the power pack onto the centre conductor of the coaxial cable which feeds the amplifier.

(4) Where an amplifier is installed the maximum cable run length can be increased where necessary. The amplifier gain should be sufficient to provide an

acceptable signal level at all connected video outlets, but not so high as to cause signal overload on the receivers concerned.

A6.9 Combining with Other Video Signals

Signals from the main free to air television antenna, a digital decoder, and VCR or DVD player may be combined with onto the same cable by means of a suitable combiner.

A6.10 Testing

As with UTP cabling, each cable run is to be tested to ensure continuity and no short circuits after the connections are made at both ends.

A6.11 Commissioning the installation

Confirm that the appropriate signal quality and level is present at each video outlet, using amplification or attenuators where necessary.

A6.12 Safety of ongoing re-arrangements by users

- (1) Care should be taken when changing the connections of coaxial cabling. Once STUs, VCRs, TVs and hi-fi systems are connected to the coaxial cabling, an electrical hazard may be present due to leakage currents or faulty equipment.

- (2) The outer shield of coaxial cable carries signals and any leakage current from faulty TV/audio/video equipment may give rise to an electric shock from the cable shield or other metal-bodied components, such as an RF splitter, When re-terminating any coaxial cables, ensure the cable is disconnected at both ends.

APPENDIX No 7

WIRELESS RETICULATION

A7.1 Introduction

(1) This Code of Practice is based primarily on the concept that generic cabling is the best option for a new home, as it is relatively low cost, provides wide bandwidth and flexibility for a range applications, it is reliable and secure.

(2) Nevertheless, wireless technology is reducing in cost and increasing in its capabilities. It also provides for mobility anywhere within the selected service area. As such, wireless technologies obviously complement generic cabling systems. For an existing home, where additional cabling is difficult and costly, wireless technologies are probably the best option, especially where the range of services needed is not extensive.

A7.2 Technology choices

(1) A number of General User Radio Licence (GURL) bands have been allocated under the New Zealand Radiocommunications Regulations. These, in most cases, align with international frequency allocations. Users of equipment in these bands are not required to gain separate operating licences, but the equipment itself is required to comply with the relevant standards. There is a wide range of such equipment now available. Anyone can use a GURL band for a range of services, subject to their not exceeding the defined power output limits and not transmitting spurious radiation from harmonics. Specific site or user licences are not required, but it does mean that interference is a distinct possibility with some combinations of products using the same radio band. As a result, one neighbour may upset another's service or there could even be interference caused by products used within the same home.

(2) For telecommunications purposes, the more relevant bands for use around the home include those allocated specifically for cordless telephones (the earlier Analogue types and more recent DECT (1.9 GHz), WDECT (2.4 and 5 GHz), etc. On the data side, the main bands are 2.4 GHz used for Bluetooth and WiFi (IEEE 802.11b/g) and 5 GHz used for IEEE 802.11a. The "a" & "g" variants offer up to 54 Mbit/s and the upcoming "n" variant will double this. Although the data rates reduce with increased range, WiFi provides an ideal transmission medium for Wireless Local Area Network (WLAN) operation. This is especially useful where mobility is required or it would otherwise be necessary to install additional cabling.

(3) Provided some care is taken when purchasing several different types of equipment for use in a home, radio interference can be minimised by ensuring that each service is using a different radio band or that the various transmitters are not sited in close proximity.

A7.3 Sources of interference

(1) With the prices of radio equipment dropping steadily, the 2.4 GHz band in particular, is already used for a wide variety of services. Not only WiFi, but 2.4

GHz and wideband DECT cordless phones, baby monitors, video senders, security cameras and wireless alarm systems, Bluetooth devices, wireless door bells, microwave ovens, etc, may all be using this same band. For example, Bluetooth and many cordless phones in use today may severely interfere with a WLAN in the same vicinity. It has been claimed that some 802.11b WLAN have been shut down by simply answering a nearby 2.4GHz cordless phone. The easiest and cheapest way of minimising mutual interference between a cordless phone and a WLAN – if it works – is to change the location of the WLAN access point and/or the cordless phone base station to maximize the distance between them. If this does not work, it may be necessary to replace the cordless phone with one operating on a different frequency band.

(2) Bluetooth operates at much lower power levels and will generally only have any impact on devices located close by. Where a WLAN device is operating at maximum distance from its access point, it will be more susceptible to interference. If it is essential that the WLAN service is available without interference in such locations, it may be necessary to install a WLAN repeater to improve the signal level. On the other hand, the WLAN can also interfere with Bluetooth to some extent, slowing down its effective bit rate.

A7.4 Security

(1) Radio devices, by their very nature, transmit in a general area limited in range by the available signal level and sensitivity of the receiver. The various technologies provide for channel selection in order to avoid channels already in local use or subject to excessive noise, but there is always some risk of cordless telephones being “overheard”. With modern cordless telephones, the possibility of an unauthorised connection to the line for “free calling” is significantly reduced by the security coding used between the base station and its handset(s).

(2) Security can be a more serious issue with WLAN’s, both as regards unauthorised access to the customer’s confidential data and access to the customer’s service. Again, a range of security precautions are available, but it is important that users realise the need to implement them and at a level appropriate to the confidentiality of their data.

