



PTC 190

Requirements for 0 - 4 kHz systems for connection to metallic copper

DRAFT FOR PUBLIC COMMENT

Access Standards
Telecom New Zealand Limited
Wellington
NEW ZEALAND

December 2010



PTC190
Requirements for the connection of 0 - 4 kHz systems to metallic copper

CONTENTS

Foreword	3
Telecom Disclaimer	3
1 General	4
2 Definitions	6
4 Electrical safety	7
5 Electromagnetic Compatibility	8
6 Power Spectral Density	9
7 Balance about earth	11
8 D.C conditions	12
9 Ringing	13

References:

Telecom Specifications:

PTC200

PTC273

PTC274

PTC285

Chorus Specification

C279

TCF Document

Interference Management Plan Parts 1 to 3

AS/ACIF S.002

FOREWORD

The purpose of this Specification is to ensure that 0 - 4 kHz services do not interfere with xDSL services operating on the same cable pair.

Typically the 0 - 4 kHz service which this specification covers is Plain Old Telephone Service (POTS), although other services which meet the requirements of this specification may also be connected.

This specification does not cover the functional or performance requirements for a POTS or any other service. These are the responsibility of the service provider concerned, and will depend upon the CPE which is connected, and interconnection with other networks.

Telecom's network interface is described in specification TNA 102.

TELECOM DISCLAIMER

Telecom makes no representation or warranty, express or implied, with respect to the sufficiency, accuracy, or utility of any information or opinion contained in this Specification. Telecom expressly advises that any use of or reliance on such information is at the risk of the person concerned.

Telecom shall not be liable for any loss (including consequential loss), damage or injury incurred by any person or organisation arising out of the sufficiency, accuracy, or utility of any such information or opinion.

The grant of a Telepermit for any item of terminal equipment indicates only that Telecom has accepted that the item complies with minimum conditions for connection to its network. It indicates no endorsement of the product by Telecom, nor does it provide any sort of warranty. Above all, it provides no assurance that any item will work correctly in all respects with another item of Telepermitted equipment of a different make or model, nor does it imply that any product is compatible with all of Telecom's network services.

1

General

1.1

Equipment covered

This Specification deals specifically with the requirement for equipment to be able to operate on a shared copper cable pair with equipment utilising frequencies between 4 kHz and 30 MHz. It does not specify the functional or service aspects, which are the responsibility of the service provider.

Where the equipment is providing POTS, it is recommended that the interface is configured to be compatible with PTC 200 compliant CPE. Information on such an interface are contained in PTA 102 and PTC 220 section 5.

- The T and R pads in PTC220 s5 reflect a loop of a few metres only so are set at 3 and 8.5 dB respectively. These include a traffic weighted mean local loop of 2.5 dB, so in a CO situation these pads would be reduced by 2.5 dB to 0.5 and 6.0 dB respectively.

1.2

Reference Model

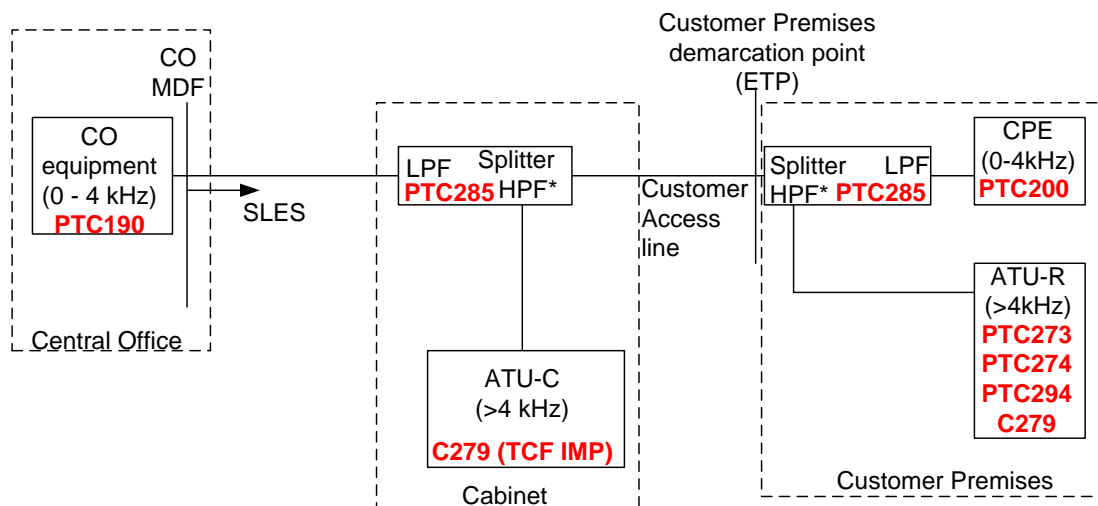

Notes:

1. HPF function may be part of the splitter or may be part of the ATU-C/R
2. This model can only be used with TCF IMP Deployment Class 6 and Class10 systems. Other deployment class systems cannot share a copper pair with 0 - 4 kHz services
3. The Figure shows the ATU-C and its associated splitter housed in a cabinet. The model is still valid for these elements to be housed in the central office building, although the PTC 190 equipment will connect to an IDF, and the MDF will be on the cable side of the splitter.

Figure 1. PTC190 reference model

1.3

Specification presentation

(1) The requirements of this Specification are printed in plain type with each paragraph formally numbered. Informal comments, recommendations and explanations which are added only as indications of the means of compliance

with this specification are shown in italics. Smaller type is used and each paragraph is preceded with a "•" symbol instead of a clause number.

(2) Mandatory requirements are indicated by use of the verb form "shall".

(3) Voluntary and preferred requirements or recommendations are indicated by use of the verb forms "should" or "may".

1.4

Equipment Configuration profiles

(1) Much of the equipment covered by this specification is highly configurable by software, firmware or configuration processes performed at installation time.

(2) When equipment is submitted for testing the correct configuration details and instructions for connection shall be supplied to the Test Laboratory.

1.5

Temperature

All products should be compliant with this Specification at all temperatures in the range -10 degrees C to +40 degrees C.

2**DEFINITIONS**

It has been noted that some terms have been used by manufacturers in different ways. For the avoidance of confusion over terms used in this Specification, they are defined as follows:-

ATU-C: Telecom xDSL equipment (DSLAM)

ATU-R: Customer Premises xDSL equipment (modem)

HPF: High Pass Filter an optional function of a splitter (main function is a low pass filter (ref PTC285)

IMP: Interference Management Plan, Spectrum management plan to minimise interference between services on different cable pairs within one cable. Compiled by the TCF and published by the Commerce Commission.

MDF: Main Distribution Frame. Point in a central Office building at which external cables are terminated and patched to internal equipment

POTS: Plain Old Telephone Service

SLES: Sub Loop Extension Service

TCF: Telecommunications Carrier's Forum

TRP: Transmission Reference Point, also known as the 0 dBr point. Point within network where losses are measured from and to.

3

Electrical Safety

3.1

General

All equipment intended for connection to the Telecom network, including plug-in cards and modules, shall conform to the safety requirements of the joint Australian and New Zealand standard, AS/NZS 60950.

- *This should not be confused with the definition of ELV applicable to electrical wiring covered by the New Zealand Electricity Regulations, where it is defined as 32 Vac rms and 115 V dc.*

3.2

External power supplies

Where the equipment is to be used with a separate external power supply, the combination of equipment plus power supply shall comply with the requirements of AS/NZS 60950.

- *Compliance testing to AS/NZS 60950, may only be undertaken by an IANZ registered laboratory, one which has been accredited by an IANZ affiliated laboratory registration authority, or one which is recognised by the Operations and Risk Management Division of the Ministry of Commerce.*

3.3

Earth connections

(1) Where, for any reason, an earth connection is necessary for the correct operation of any equipment, the requirements of AS/NZS 60950 shall be complied with.

- *Telecommunications equipment is referenced to both the local exchange earth and the remote customer premises earth. In the event of power faults or lightning strikes causing a rise in earth potential in the vicinity of the customer's premises, insulation breakdown is likely to result.*

4

Electromagnetic Compatibility

4.1

Radiated energy requirements

(1) All equipment shall comply with the Radiocommunications Act 1989 and Radiocommunications (Radio) Regulations 1993 as regards radiated energy. These requirements are administered by the Ministry of Economic Development and responsibility for such compliance rests with the Telepermit applicant.

- *Any microprocessor-based equipment is likely to give rise to unwanted radiation and it is advisable that this aspect be checked before any equipment is released onto the New Zealand market.*

(2) All equipment covered by this specification shall comply with
AS/NZS CISPR22

4.2

Immunity from radiated energy

It is strongly recommended that all devices satisfy the requirements for immunity to radiated electromagnetic energy as stated in the joint Australian and New Zealand standard, AS/NZS 4252.

- *The acceptable equivalent European standard is CENELEC/CEN 50082-1:1992.*

5 Power Spectral Density

5.1 Maximum signal in an on-line condition

5.1.1 0 - 4 kHz Band

0 - 4 kHz: -9 dBm Averaged over 1 minute, Z = 600 ohms, -2.86 dBm Peak

The peak value shall be measured with +3.14dBm applied at the 0 dBr point.

- This is the maximum signal which can be handled by a g.711 A-law codec.
- Where other codecs are used the signal injected at the 0 dBr point should be discussed with the Test Laboratory. The intention is to drive the codec to produce its maximum analogue output to line.
- Voiceband data signals tend to remain close to their average values, and are usually in the range of -15 to -9 dBm. Voice signals tend to an average of about -25 dBm, but can have peaks regularly exceeding 0 dBm.
- This requirement also applies to supervisory tones, caller ID DTMF and any other signals which may be transmitted from the equipment

5.1.2 Signals above 4 kHz

- (1) From 4 kHz to 30.175 MHz the signals shall not exceed the limit shown in Figure 2 when measured into a 135 ohm load using a noise power bandwidth of 1 kHz from 4 kHz to 100 kHz, and 10 kHz from 100 kHz to 30 MHz.

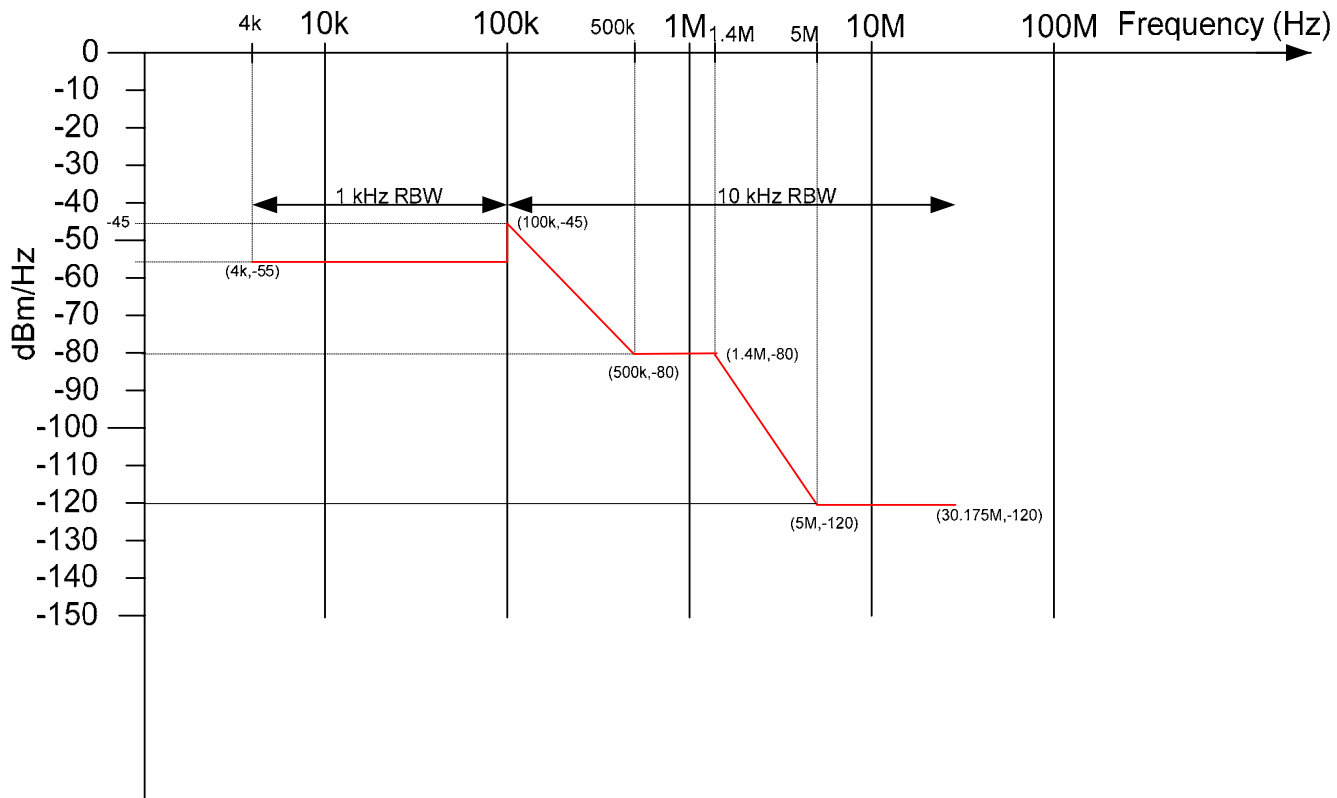

Figure 2 PSD limits for signals above 4kHz

- (2) The PSD of signals in between 300 kHz and 30.175 MHz shall be less than the limit shown in Figure 3, when measured as the average power within a 1MHz sliding window.

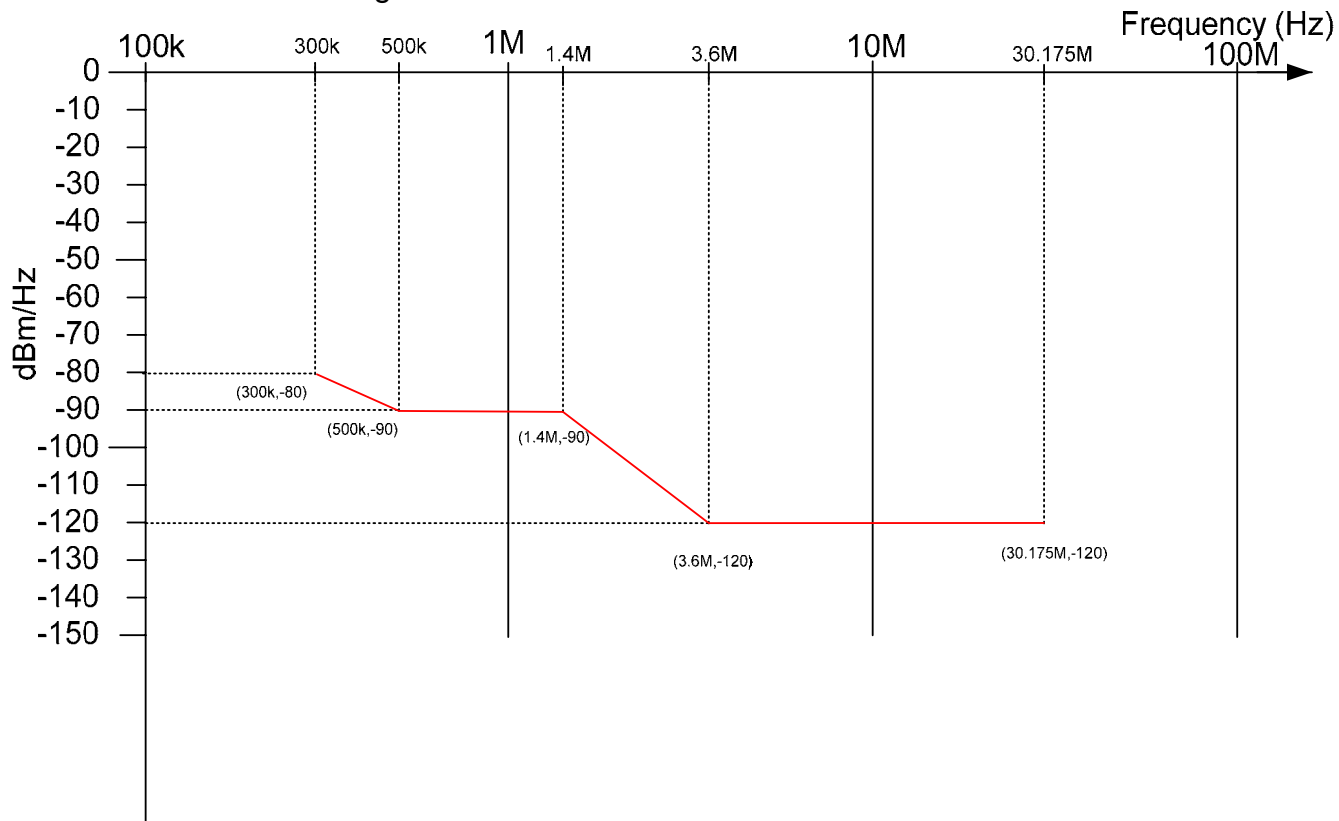
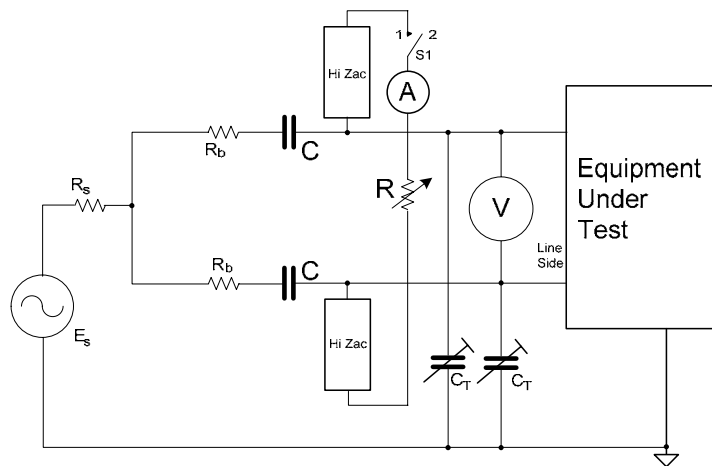

Figure 3 PSD limits for signals between 300 kHz and 30.175 MHz

6

Longitudinal Balance about earth

The Longitudinal conversion ratio (LCR) (ITU-T Rec G.117 para 4.1.3) at the line port of the equipment shall be not less than 40dB over the frequency range 300Hz to 30 MHz, with the equipment in both an on-line and off-line condition.



Notes:

1. R_s to be 600 Ohm for frequencies 300 to 4000 Hz and 25 Ohm for frequencies 4 kHz to 30 MHz (source impedance of generator)
2. R_b to be 300 Ohm for frequencies 300 to 4000 Hz and 25 Ohm for frequencies 4 kHz to 30 MHz and to be matched to 0.1%
3. DC Blocking capacitors marked "C" to be greater than 400 μF for frequencies 300 to 4000 Hz and greater than 10 μF for frequencies 4 kHz to 30 MHz
4. The total DC loop resistance of the two Hi Z impedances in series with R shall be 400 Ohms.
5. ON-line measurements are made with S1 set to position 1 and off-line measurements when S1 set to position 2
6. CT are small value capacitors (30 pF) used to balance the test circuit prior to testing
7. Signal source to be 0 dBm (600 Ohm) measured at E_s , from 300 to 4000Hz, and 0 dBm (100 Ohm) from 4 kHz to 30 MHz
7. Longitudinal Balance = $20 \log_{10}(E_s/V)$

Figure 4 Test setup for measuring longitudinal balance

7

DC characteristics

7.1 General

There are two alternative recommended methods of locally powered line feed as follows:-

(a) A d.c. Voltage, fed via a constant impedance source (commonly 400 ohm), with current usually limited at some value below 80 mA.

(b) Constant or restricted current in the range 18 mA to 45 mA.

- *The line feed is normally applied as negative battery (relative to earth) on one wire and earth on the other. This is not however mandatory for this application. CPE devices are required to be polarity insensitive so it is not necessary to specify a particular polarity for line feed.*

7.2 Requirements

7.2.1 The maximum voltage applied to the line shall be 60V d.c.

7.2.2 The maximum current shall be limited to 80mA

7.2.3 Ripple components shall not exceed 2 mV psophometric measured into loads of 1000 ohm and 50 ohm.

8 Ringing Characteristics

Where low frequency AC ringing is used, the ringing source shall satisfy the following requirements:-

- 8.1 The ringing supply shall comply with the electrical safety requirements of AS/NZS 60950.
- 8.2 The ringing voltage and duration shall comply with the TNV requirements of AS/NZS 60950, Section 6.
- 8.3 The maximum ringing voltage (Open Circuit) shall be 75Vrms, subject to clause 8.2
- 8.4 The ringing frequency shall be in the range 16 to 30 Hz. The preferred value is 25 ± 1 Hz.
- 8.5 The crest factor of the ringing waveform shall be between 1.2 and 1.6.
 - *The crest factor is defined as the ratio of the peak to r.m.s. voltage, and this equates to a value of 1.414 for a pure sine wave.*
- 8.6 The PSD requirements of section 6 shall be met while ringing is applied to a load of 1.6 kOhm in series with 5 microfarads.