

**SPECIFICATION PTC
226: 2006 TELECOM
REQUIREMENTS FOR
TWO WIRE TWO PIN
JACKPOINTS**

**Access Standards
Telecom New Zealand
Limited
Wellington
New Zealand**

PTC 226: Version 2006

Contents	Section-Page
TELECOM DISCLAIMER	vi
WARNINGS	vi
FOREWORD	vii
1. SCOPE	3
1.1 BT socket “2-wire” system	3
1.2 Compatibility issues	3
1.3 Reliability	3
1.4 Physical design of Jackpoint assemblies	4
1.5 Design and development rights	4
2 GENERAL	5
2.1 Mode of presentation	5
2.2 Related Specifications	5
2.3 Marketing features	5
2.4 Unauthorised use of Intellectual Property	5
3 DEFINITIONS	6
4 BACKGROUND	9
4.1 Current position	9
4.2 Benefits of 2-wire operation	9
4.3 Ringing issues	10
4.4 Mixed wire gauges	10
4.5 Jackpoint faceplate design	11
4.6 Telecom maintenance responsibilities	11
4.7 Telecom maintenance service implications	12
4.7.1 Product status	12
4.7.2 Fully interchangeable products	12
4.7.3 High quality products of non-standard or special types	12
4.7.4 Non-Telepermitted products	13
5. LABORATORY TESTING AND DESIGN OF THE “2C” JACKPOINT	15
5.1 Testing requirements	15
5.2 Outcome	15
5.3 Approved components and processes	15
5.4 Qualification of other components	15
5.5 Designs other than that specified	16
6 JACKPOINT REQUIREMENTS	17
6.1 Component and process requirements	17
6.2 Socket assembly	17
6.3 Wiring terminations	17
6.4 Printed circuit board material	18
6.5 Protective coating materials or Protective Cover	18
6.6 Solder	19
6.7 Alternative components	19
6.8 Installation instructions	19
7 CONSTRUCTION AND MANUFACTURING PROCESSES	20
7.1 Interchangeability with Telecom mounting hardware	20
7.2 Printed circuit board design and assembly	20
7.3 Mechanical assembly	21
7.4 Cleaning	21
7.5 Application of protective coating	21
7.6 Faceplates and construction	22

7.7	Mounting Boxes	23
8	ENVIRONMENTAL REQUIREMENTS.....	24
8.1	Temperature and humidity	24
8.2	Hydrogen sulphide	24
8.3	Construction.....	24
9	MOUNTING HARDWARE	25
9.1	General design issues.....	25
9.2	Dampness protection	25
9.3	Dust and dirt protection	25
10.	PRODUCT MARKINGS	26
10.1	Telecom Logo	26
10.2	Telepermit label.....	26
10.3	Telepermit logo	26
10.4	Terminal numbering	26
10.5	Manufacturer's identification.....	27
10.6	Faceplate marking.....	27
10.7	Warnings and other consumer information	28
11	QUALITY ASSURANCE	29
11.1	Quality system	29
11.2	Production consistency	29
11.3	Authorisation of changes.....	29
11.4	Product traceability.....	29
11.5	Quality monitoring	30
12	WARRANTY AND ONGOING SERVICING.....	31
12.1	Service reliability	31
12.2	Warranty	31
12.3	Warranty conditions	32
12.4	Ongoing servicing by Telecom.....	32
13	SAMPLES AND DOCUMENTATION.....	33
13.1	Manufacturer Self-certification	33
13.2	Samples	33
13.3	Design changes	33
14	TESTING	34
14.1	Confirmatory testing.....	34
	APPENDIX No. 1 Acceptable Components and Materials.....	35
A1.1	Socket components	35
A1.2	Insulation displacement connectors.....	35
A1.3	Protective coating material	35
	APPENDIX No. 2: Cleaning Requirements for Printed Wiring Assemblies.....	37
A2.1	Post soldering cleaning	37
A2.2	Cleanliness	37
A2.3	Cleanliness test	37
A2.4	Inspection lot for cleanliness verification	38
A2.5	Failed batches	38
A2.6	Rejected lots.....	39
A2.7	Typical cleanliness test procedure.....	39
	APPENDIX No. 3 Coating Requirements for Printed Wiring Assemblies.....	40
A3.1	Dipping requirements	40
A3.2	Drying and thereafter.....	40
A3.3	Dipping tank maintenance	41

APPENDIX No. 4: Summary of Documentation to be Submitted	42
APPENDIX No. 5 Telepermit Assessment Schedule	44
A5.1 General	44
A5.2 Design	45
A5.3 Corrosion resistance	45
A5.4 Reliability of wiring	45
A5.5 Components	45
A5.5.1 Sockets	45
A5.5.2 Wiring terminations	45
A5.5.3 Printed Circuit Board	46
A5.5.4 Protective coating	46
A5.5.5 Solder	47
A5.6 Construction and Manufacturing Process	47
A5.6.1 Interchangeable with Telecom	47
A5.6.2 Mechanical Assembly	47
A5.6.3 Cleaning	48
A5.6.4 Application of protective coating	48
A5.7 Product Markings	48
A5.8 Installation instructions	49
APPENDIX No. 6:- Diagrams Relating to the 2c Jackpoint	50
Circuit Diagram for 2c Jackpoint	50
Typical Physical Layout of a Telecom 2c Jackpoint	51
Mounting Box and Protective Cover	52
Telepermit Label Formats	53

RELATED DOCUMENTS

PTC 100	Telecom Permit to Connect: General Conditions
PTC 103	Code of Practice for the Installation of Customer Premises Telecommunications Wiring

In addition, the following Standard Specifications are referred to in this Specification:

BS 214: 1977 (1984) - Resin-Cored Solder Wire. (NZS 543).

ANSI/IPC-D-320 (1978) - Printed Board, Rigid, Single and Double sided, End Product Specification.

ANSI/IPC-S-815A - General Requirements for Soldering Electronic Interconnections.

BS 6001:1972 Sampling Procedures and Tables for Inspection by Attributes.

BS 6312-2.1:1994 Plugs for use with British Telecom Line Jack Units.

TELECOM DISCLAIMER

Telecom makes no representation or warranty, express or implied, with respect to the sufficiency, accuracy, or utility of any information or opinion contained in this Specification. Telecom expressly advises that any use of or reliance on such information is at the risk of the person concerned.

Telecom shall not be liable for any loss (including consequential loss), damage or injury incurred by any person or organisation arising out of the sufficiency, accuracy, or utility of any such information or opinion.

The grant of a Telepermit for any item of customer premises terminal equipment normally indicates only that Telecom has accepted that the item complies with minimum conditions for connection to its network. It indicates no endorsement of the product by Telecom, nor does it provide any sort of warranty. Above all, it provides no assurance that any item will work correctly in all respects with another item of Telepermitted equipment of a different make or model.

In the case of the jackpoint assemblies covered by this PTC Specification, special conditions apply as the result of Telecom's Wiring Maintenance Services. For those customers subscribing to the service, Telecom will replace, without additional cost to the customer, any Telepermitted jackpoints installed in accordance with Telecom's Code of Practice for Residential-Type Customer Premises Wiring, PTC 103, but which fail through normal use. Product which is to be covered by this maintenance service must be manufactured to the defined standards (in order to achieve acceptable reliability).

WARNINGS

Telecom's contractual arrangements require its residential customers to connect ONLY Telepermitted products to their lines.

This also applies to the hardware connected to their fixed wiring, especially where the customers concerned pay Telecom a monthly fee to repair that wiring and its associated jackpoints.

Should suppliers offer any non-Telepermitted 2-wire jackpoints of a type described in this Specification and imply that they are suitable for use in customer premises wiring which is connected to the Telecom network, they are likely to be in breach of the Consumer Guarantees Act 1993.

Similarly, where products which have been granted a Telepermit are proved NOT to comply with the requirements of this specification, Telecom reserves its rights under New Zealand law to take legal action against the supplier in order to recover any costs incurred as a result of that non-compliance.



FOREWORD

This Specification defines Telecom requirements for the grant of a Telepermit for jackpoint assemblies manufactured in accordance with Telecom's latest "2-wire" design, which is referred to as the "2c" jackpoint.

Telecom has a duty of care to its customers to ensure that all reasonable steps are taken to give reliable and high quality service. Since their introduction in 1983, the reliability of jackpoints has proved to be an important factor in determining the overall reliability and availability of Telecom's public telephone network services. For this reason, Telecom has to insist on relatively high standards of manufacture to ensure that premature failure and resultant service disruption to customers are minimised.

The "2-wire" design, introduced by Telecom in 1996, incorporated a number of improvements in relation to the earlier 3-wire versions, which were based on or equivalent to the original British Telecom design. At its own expense, and as part of its continuing efforts to improve the level of service offered to its customers, Telecom has progressively replaced most of the earlier 3-wire designs covered by Specification PTC 203. This work has been done during fault clearance work visits to customers' premises.

The trigger for the "2c" jackpoint was the decision by ITT-Cannon Ltd to withdraw production of their BT socket with enhanced plating, as specified in the earlier versions of this Specification. This led to investigations to find another acceptable socket and determine whether or not such a socket would maintain the present level of reliability. Laboratory testing during 2005 gave the opportunity to determine whether further improvements in corrosion resistance could be achieved. Basic design parameters were reviewed in the light of CPE changes over recent years. Given that there are now much lower numbers of older 3-wire connected telephones remaining in service, a ringing capacitor in every jackpoint is no longer essential. With no ringing capacitor, a 2-contact version of the basic BT socket could be considered. This was found to offer significant improvement in corrosion resistance. In the relatively few cases where such older telephones need to be connected via a 2-contact jackpoint; it is far more economic to provide plug-in ringing adapters than to incorporate a ringing capacitor within every jackpoint.

To differentiate these latest versions from previous types, they are being referred to as "2C" (two contact) jackpoints.

The need for reliability implies that the supplier should accept some of the responsibility for ensuring that poor quality items are not supplied to the market. Notwithstanding the selection of "proven components", freedom from chemical contamination and properly applied protective coating remain the responsibility of the party manufacturing the end-product.

This specification requires that all reasonable steps are taken to ensure reliability during the design and manufacturing stages.

The grant of a Telepermit usually indicates only that a particular brand and model of product may be connected to the Telecom network under the terms of Section 106 of the Telecommunications Act, 2001. As far as jackpoints are concerned, the grant of a Telepermit also indicates Telecom's willingness to replace the faulty units as part of its wiring maintenance service.

Jackpoints do not appear to be a particularly complex item. Nevertheless, with some 5 million of them in service, even a reliability level of 100 years Mean Time Between Failures corresponds with 50 000 customers experiencing service problems every year!

Because it is important that suppliers understand the issues relevant to this relatively simple piece of hardware, a considerable amount of background information is given in this Specification.

Telecom aims for a high level of co-operation with jackpoint suppliers, as it is only through such co-operation that Telecom will be able to ensure that jackpoint failure continues to be reduced as a major source of service problems for our customers.

1. SCOPE

1.1 BT socket “2-wire” system

(1) Telecom adopted the plug and socket system of terminal equipment connection originally designed by British Telecom (BT) as the standard for all its telephone installation work in 1983. This was done to provide for the much wider range of Customer Premises Equipment (CPE) then being brought into in service. The BT socket is now used in virtually all residential installations and a very high proportion of small business installations, using what are termed the “2-wire” system.

(2) This Specification defines the minimum requirements for jackpoints designed to the Telecom “2-wire” system. These latest “2c” versions drop the requirement for an integral 1 microfarad ringing capacitor and now incorporate a BT socket with only 2 contact springs in place of the usual six.

(3) While these new jackpoints are compatible with the great majority of customer premises terminal equipment now in service and connected by means of a mating plug specified in British Standard 6312, they no longer provide ringing current for any older 3-wire connected telephones remaining in service. In the relatively few cases where such telephones are connected via these new jackpoints, a simple ringing adapter will be needed.

(4) With the publication of this revised PTC 226 specification, PTC 223-series Telepermits granted to the earlier 2-wire jackpoints continue to be valid until such time as manufacturers run out of the ITT-Cannon 6-contact sockets.

(5) Jackpoints using sockets other than the BT socket, such as RJ12 and RJ45, are not covered by this Specification.

1.2 Compatibility issues

There are a number of critical dimensions to be maintained to ensure the correct fitting of plugs and sockets and ease of replacement of complete jackpoint assemblies. These factors, and the need for assurance that contact spring plating is to specification, have led Telecom to specify “accepted” types of the socket that must be used for Telepermit purposes.

1.3 Reliability

(1) Telepermit applicants shall take special note that service reliability is of paramount importance. Telecom has now replaced millions of the original 3-wire jackpoints with its own 2-wire version as a preventative maintenance measure. Because many other types of 2-wire jackpoints may be installed in significant quantities, there is potential to inconvenience large numbers of customers if any specific types prove unreliable. In the case of jackpoints, the cost of visiting the customer to replace a faulty one could be as much as fifty times its initial cost.

(2) For privately-supplied and installed line hardware to be granted a Telepermit and be covered by a Telecom standard wiring maintenance contract, it must be shown to

comply with the standards of reliability, dimensional accuracy and other requirements set by this Specification.

(3) This Specification provides extensive background information for suppliers to assist them in understanding the in-service performance requirements of the hardware and the reasoning behind its design.

1.4 Physical design of Jackpoint assemblies

(1) This Specification does not restrict applicants to supplying identical versions of Telecom jackpoint designs. Any other designs which have been shown to meet the technical requirements of this Specification will be considered for the grant of a Telepermit. This provision includes the jackpoint “modules” now widely used in those wiring installations where the customer requires telephone jackpoints match their 230 V outlets and switches.

(2) Potential suppliers are warned that faulty jackpoints of a Telepermitted design which is physically incompatible with the standard Telecom range can not be replaced by an identical item under a Telecom wiring maintenance contract. Telecom will only provide a functional replacement of the faulty non-standard item at no cost to the customers concerned.

(3) Where a customer insists on an identical replacement of a faulty jackpoint to a physically incompatible design, Telecom will only be able to disconnect the faulty unit. In such cases, the customer will be required to arrange the purchasing and installation of the direct replacement and meet all the costs incurred.

- *These warnings need to be passed on to customers under the terms of the Consumer Guarantees Act 1993.*

1.5 Design and development rights

(1) The availability of a wide range of jackpoints on the local market in no way implies that such designs or concepts may be copied by any other manufacturer.

- *Telecom’s suppliers may have intellectual property rights over certain aspects of their particular designs. As such, any proposal to copy all or parts of a design need to be checked out with the manufacturer concerned.*

2 GENERAL

2.1 Mode of presentation

(1) The general requirements of this Specification are printed in plain type with each paragraph formally numbered. The words “should” or “may” are used where a requirement is desirable, but not mandatory.

(2) Mandatory requirements are indicated by use of the verb form "shall" and clauses including such requirements are highlighted as demonstrated here.

(3) Informal comments, recommendations and explanations which are added only as indications of the means of compliance with this specification are shown in italics. Smaller type is used and each paragraph is preceded with a "•" symbol instead of a clause number.

2.2 Related Specifications

(1) For any Telepermit application to be successful jackpoints shall comply with the mandatory requirements of this Specification and any mandatory requirements of the related specifications and standards called up by this Specification.

(2) As outlined in Specification PTC 100, where any conflict arises between the requirements of general Specifications and those of this product Specification, the requirements of this Specification shall take precedence.

(3) Where other national or industry specifications are called up, other equivalent specifications may also be acceptable to Telecom. Where product to such other specifications is proposed, details of those specifications are to be supplied to Telecom as part of the Telepermit application.

2.3 Marketing features

Some equipment features or characteristics are regarded as purely marketing issues and their requirements are therefore not necessarily dealt with in this Specification. However, in cases where clarification is considered desirable, explanatory notes are provided.

2.4 Unauthorised use of Intellectual Property

(1) Telepermit applicants and holders shall indemnify Telecom against any claims which may result from the granting of a Telepermit to jackpoints which are later found to have breached another party's intellectual property.

(2) This indemnity also applies to any claimed breach of copyright or non-payment of royalties.

• *Applicants are warned that such claims may also arise with copies of printed circuit board layouts, use of proprietary terminal strips and other design features the rightful ownership of which is not known to Telecom.*

3 DEFINITIONS

2-wire jackpoint: any accepted version of Telecom's standard telecommunications outlet to be used for residential-type customer wiring systems connected to the Telecom network.

- *For the purposes of this Specification, the term "jackpoint" is used to describe the complete unit made up of the printed circuit board assembly and its faceplate and shutter assembly. This is done to avoid confusion with the term "socket", which is applied only to the BT-designed socket component.*
- *Other types of telecommunications outlet may also be used in customers' premises, especially those of business customers who have integrated (generic) cabling systems, such as SOHO.*

2c jackpoint: the latest versions of Telecom's standard telecommunications outlet providing only two contact springs and improved corrosion resistance

2-wiring: the standard wiring termination system adopted by Telecom, which provides for only the two line wires to be terminated on jackpoints.

- *While only two wires are terminated, 2, 3 or 4-pair cables may be used, the additional pairs being available for future services.*
- *2-wiring caters for parallel (or looped) and star wiring arrangements, as required by the customer. Star wiring is generally desirable where 2 or more exchange lines are likely to be needed.*

Accessory: any device, not itself directly providing a telecommunications function, readily fitted or removed by the user, such as a double-adapter plug, extension cord, cord connector, etc, which is intended to be inserted into a jackpoint connected to the premises wiring.

Dual outlet jackpoint: any jackpoint faceplate providing two BT sockets or a BT socket and some other type of socket, whether for two separate lines, or for two appearances of the same line.

Hardware: the general term to describe any termination, fitting or jackpoint associated with the telecommunications wiring.

Master Jackpoint: the 3-wire jackpoint previously used by Telecom, in which a test termination and common ringing capacitor is fitted.

- *As these may no longer be installed, their Telepermits have been cancelled.*

Modular style jackpoint: any telephone jackpoint assembled as a module suitable for insertion in standard rectangular electrical faceplates.

- *This definition covers modules of the various makes and physical dimensions used by suppliers of electrical hardware.*

Parallel wiring: the system adopted by Telecom for customer premises wiring which requires that all jackpoints providing access to a line are terminated in the same way and in electrical parallel.

- *The simplest arrangement is to "loop" from one jackpoint to the next, connecting each in a continuous chain. Preferably, each jackpoint should be "star" wired back to a central point. In both cases, the jackpoints are connected in electrical parallel across the two line wires. Looping is the least cost option, as it involves the minimum length of cable run. Star wiring uses additional cable and connection hardware, but has the advantage that the installation can be split to handle two or more lines whenever necessary.*

Ringin adapter: any device incorporating a 1 microfarad capacitor, connecting to a "2c" jackpoint via a BT plug and providing a 3-wire ringin connection via pin 4 of a standard 4 or 6-contact BT socket.

Secondary (Extension) jackpoint: the 3-wire jackpoint previously used by Telecom for all extension outlets other than the one at which the Master Jackpoint is fitted.

- *This older type now has only limited application, typically for data services or for any CPE requiring other than the standard 2-wire or 3-wire terminations.*

Socket: the BT socket component which mates with a plug to BS 6312 and which forms an essential part of any jackpoint assembly complying with this Specification.

- *The original British Telecom components were defined as BT 601A (plug aperture parallel with the circuit board) or BT 605A (plug aperture perpendicular to the circuit board). The latter are commonly used on modular style jackpoints.*

Star wiring: an optional system for customer premises wiring which requires that all jackpoints providing telecommunications access points are terminated, along with the network terminations, at a common location.

- *Provision for variable cross-connections between the network and jackpoints should preferably be made at this common location. Such issues are covered in PTC 103 and PTC 225.*
- *Star wiring is the recommended practice for all new installations.*

Telecom specifications: in relation to premises wiring practices, the term "Telecom specifications" refers specifically to Specification PTC 103, Telecom's Code of Practice for Customer Premises Wiring".

- *While PTC 103 is the primary reference, it is not likely to be used by customers or even by some professional installers. In practice, many customers will install their own jackpoints to simple "Do it yourself" instructions provided with the jackpoint concerned. These instructions will be required to be in compliance with PTC 103; so that customers are not misled into breaching the terms of Telecom's wiring maintenance service.*

Wiring (premises wiring): any telecommunications wiring, permanently installed within a customer's premises, including the associated jackpoints, cross-connection hardware, Line Break-in, and test access points hardware, etc, which are on the customer's side of the network demarcation point of an individual Telecom line.

- *For the purposes of this Specification, "Wiring" does not include:-*
 - any plug-in accessories, or*
 - any plug-in terminal equipment, or*

- (c) *any fixed terminal equipment.*
 - (d) *any fixed wiring connected to demarcation hardware used to separate the telecommunications wiring from security alarms, remote power and services metering equipment, etc.*
- *For the definition of the network demarcation point and an explanation on its significance, see Telecom Code of Practice PTC 103.*

4 BACKGROUND

4.1 Current position

(1) Telecom introduced the BT plug and socket system for telephone and related services wiring in 1983. It is estimated that there are now well over 4 million jackpoints in service, with the great majority of CPE items using BT plugs.

(2) The British Telecom-developed "3-wire" system was originally used. This introduced a third "ringing wire" to overcome bell tinkle or "sunder chirp" during decadic dialling. It brought many benefits over the earlier Post Office "Plan Wiring" systems, especially as regards the simplicity of both premises and CPE wiring. However, noise induction, from such sources as lamp dimmers, electric fences, power lines and local radio stations, was a common problem with the 3-wire system; especially where several jackpoints are fitted and long wiring runs are involved. Uneven sharing of ringing current via the common ringing capacitor led to some CPE not detecting incoming calls. Also, even three wires can be connected in several ways and "Do it Yourself" installers commonly suffered "problems" when properly functioning CPE was connected to incorrectly wired jackpoints.

(3) However, a far more significant problem was jackpoint corrosion. This affected the printed circuit boards, sockets and IDC connectors. There were numerous causes, but most of them related to the local environment in the customer's premises.

(4) Telecom's exchanges later converted to "all-electronic" with no inductive power feeds and DTMF (tone) signalling replaced decadic signalling. These changes provided the opportunity to simplify wiring practices by introducing our "2-wiring" scheme. This provided a number of side benefits, just one of which was the greatly improved corrosion resistance of the "2-wire" jackpoint.

(5) The great majority of CPE in service is 2-wire connected, as the "preferred" practice. This aligns Telecom practice with that of most of the world market.

4.2 Benefits of 2-wire operation

(1) The original move to "2-wire" operation in 1996 provided the following significant benefits:-

- (a) Separate "Master" and "Secondary" jackpoints were no longer required, as the test termination in the Master jackpoint was moved to the Network Termination Point;
- (b) Ringing performance was improved as current is not limited by the shared capacitor in a Master jackpoint.
- (c) Noise problems were significantly reduced by the improved line balance, especially for dial-up modems and fax machines;
- (d) Transient voltages resulting from longitudinal surges (such as those caused by lightning) were reduced to the extent that a surge suppressor was no longer required in all installations;

- *With the improved line balance, a surge suppressor needed to be fitted by Telecom only at installations in known lightning-prone areas.*

(e) Wiring was simplified - only two wires in the cable needed to be terminated, with no polarity problems;

(f) Up to three different conductor gauges could be reliably connected by making use of the three IDC slots connected to each line wire;

- *This provided the solution to another cause of unreliability in that different wire gauges had commonly been connected within the same IDC slot, leading to potential joint failure and noise problems.*

(g) Electrolytic corrosion was reduced by dispensing with the third wire and providing wider clearances between the printed circuit board tracks. These changes avoided having a continuous 50 V d.c. potential difference between adjacent pins of the socket assembly;

(h) Socket corrosion was reduced by enhanced plating requirements;

(i) Improved cleaning, drying and protective coating over the entire jackpoint circuit board and components further enhanced corrosion resistance and service reliability for customers.

4.3 Ringing issues

(1) By 1996, when 2-wire operation was introduced, most CPE had an integral ringing capacitor and was 2-wire connected. Nevertheless, a separate ringing capacitor had to be provided in each jackpoint to support the reasonably large number of 3-wire connected telephones that were in service at that time.

- *Unfortunately, there is no indication to a customer whether an older telephone is 2-wire or 3-wire connected, so it was decided to provide for all 2-wire jackpoints to support these older telephones.*

(2) There are considerably fewer of these older 3-wire telephones remaining in service, most of them already well over 10 years old. With the numbers declining steadily, it is no longer necessary to provide a ringing capacitor within every jackpoint. Where it proves necessary to replace an earlier jackpoint with a new "2c" version and such an old telephone is still being used, a simple ringing adapter can be provided.

4.4 Mixed wire gauges

(1) Typically, 0.4 mm, 0.5 mm and 0.63 mm conductors may be present in Telecom customers' premises. This often led to two conductor sizes being terminated in the same IDC connector slot, reducing contact reliability.

- *This situation arose due to the change from 0.5 mm to 0.4 mm in 1981 and the use of even heavier gauges for lead-in wires.*

(2) Both the standard 2-wire jackpoint and the new "2c" jackpoints incorporate two three-slot IDC strips, each with its slots "commoned" together. With one strip used for each line wire, each strip can cater for three different wire gauges up to and including 0.63 mm without the need to fit mixed gauges in the same slot.

(3) The requirement for 3-slot IDC strips was relaxed for modular-type jackpoints mounted in electrical industry standard rectangular faceplates. This relaxation was accepted in view of the limited space within flush boxes and the restrictions set by the faceplate aperture dimensions adopted by the major suppliers of electrical hardware in New Zealand. Despite the reduced spacing between adjacent line wire connections in such modules, a 4-slot IDC strip was considered acceptable on the basis that these modules are not used by Telecom as standard replacements.

4.5 Jackpoint faceplate design

(1) Most of the jackpoints used by Telecom are based on designs originally developed by British Telecom. Telecom formally adopted only the 67 mm square version of the original three standard British faceplate sizes for its own use. The majority of jack-points currently in service use the same faceplate design as the British Telecom LJU2 (Line Jack Unit 2).

- *The timber-frame building construction generally used in New Zealand and customer demand for flush-mounted jackpoints led to a redesign of the original BT-designed line hardware to incorporate a more compact circular printed circuit board. The circular boards have been used with the standard 67 mm square faceplate and a range of plastic mounting hardware providing for flush, semi-flush and surface mounting of jacks and terminal blocks. The most common practice now is to surface mount the jackpoint on a square Mounting Box. See Fig. 3*
- *Recent changes to Telecom's own 2-wire jackpoints include the use of a more efficient printed circuit board design but, other than for the copper track layout, the electrical design is unchanged.*

(2) Telecom also uses jackpoints mounted in rectangular (115 mm x 80 mm) 230 V electrical hardware faceplates matching the most commonly used current styles. These single and dual outlet units use shutter components similar to those of the standard Telecom jackpoint.

4.6 Telecom maintenance responsibilities

As part of its complete telecommunications service to its customers, Telecom provides comprehensive fault reporting and clearance services. These include a premises wiring maintenance service. The general terms of this service are as follows:

- *Such contracts currently apply to virtually all residential customers.*
- *For the payment of a monthly fee Telecom will provide free repair for the premises wiring and any faulty jackpoints for which a Telepermit has been granted.*
- *Jackpoints which hold a valid Telepermit and which are fully compatible with Telecom's own product range will be replaced free of charge, unless they have been subjected to mechanical damage or have not been wired in accordance with Telecom Code of Practice, PTC 103.*
- *Any privately-supplied jackpoint which holds a Telepermit, but is not included in the standard Telecom product range, will be replaced by a functional equivalent from Telecom's own range.*
- *Where the fault is due to wiring not carried out in accordance with Telecom's requirements, where mechanical damage has occurred, or where the fault is due to hardware for which a Telepermit has not been granted, the customer will be required to pay Telecom's charges for the visit and for any work carried out.*

4.7 Telecom maintenance service implications

Because all jackpoints are connected in electrical parallel across the line, corrosion in any one of them has the potential to totally disrupt the customer's service.

4.7.1 Product status

The implications of the Telecom maintenance service for suppliers of jackpoints are that there are two classes of Telepermit that can be granted under the terms of this Specification:

(a) Items which are fully interchangeable with the Telecom range of hardware in overall dimensions, appearance and basic physical design, and

(b) Items which, because they provide special features or are otherwise not directly interchangeable with Telecom items, can be replaced only by generally equivalent Telecom items free of charge under a Telecom wiring maintenance contract.

- *For option b items, the customer may supply an identical replacement item or choose to arrange for one to be supplied and installed by a party other than Telecom.*
- *Typical cases of "b" are jackpoint modules used in rectangular faceplates, especially where other types of modules are also fitted in the same faceplate. Similarly, where the larger LJU 1 dual outlet jackpoints or others in a different format to that used by Telecom are used, it is not practicable for Telecom to provide an identical replacement for a faulty item. This may be due to mounting differences or inability for the Telecom replacement to provide a "cosmetic" solution acceptable to the customer.*

4.7.2 Fully interchangeable products

(1) Items in (a) above which fail in service will be eligible for replacement by an equivalent item under a Telecom wiring maintenance contract. For such items, suppliers shall provide sufficient quality assurance information to satisfy Telecom that the products concerned will not represent an unacceptable risk of failure in service.

(2) The information and assurances required to gain a Telepermit for each product concerned are covered in Section 10.

(3) It is recommended that suppliers granted a Telepermit for any hardware product in this category offer the item for sale with a statement to the effect that

"This Jackpoint has met all Telecom requirements and will be replaced under a Telecom customer's wiring maintenance service provided that it is installed in accordance with Telecom specifications".

4.7.3 High quality products of non-standard or special types

(1) Products in (b) above which are granted a Telepermit will not be replaced free of charge with identical items under a residential wiring maintenance agreement.

(2) The connection of such products, when installed in compliance with Telecom specifications, will not affect a customer's rights under a wiring maintenance contract. Where faults occur, it will be replaced free by a functional equivalent from the Telecom range unless the customer elects to pay the full costs of another party installing an

identical replacement. In such cases, the Telecom service staff will simply disconnect the faulty item to restore service via the other jackpoints on the same line.

(3) To comply with the requirements of the Consumer Guarantees Act, 1993, suppliers granted a Telepermit for any hardware product in this category shall offer the item for sale with a suitable warning regarding its status under Telecom's wiring maintenance service.

- *It should be noted by suppliers that virtually all Telecom residential customers and many business customers subscribe to this wiring maintenance service. Even if jackpoints are offered for sale at trade outlets, such a warning needs to be passed on by the installer to the end customer under New Zealand consumer legislation. The fact that jackpoints are a product sold to consumers in general does NOT give protection to suppliers when the product is sold to Telecom business customers.*

(4) It is recommended that this warning be a statement along the following lines:

"This Jackpoint has been granted a Telepermit but, under the terms of Telecom's wiring maintenance service, it can only be replaced by the closest functional equivalent from Telecom's own product range. Free replacement applies only if it is installed in accordance with Telecom's Code of Practice, PTC 103. If you elect to have it replaced by an identical item, you will have to make the necessary arrangements independent of Telecom and you will be required to pay all costs".

4.7.4 Non-Telepermitted products

(1) Non-Telepermitted jackpoints are specifically excluded from the standard Telecom wiring maintenance service. To connect them to the Telecom network without clear agreement from Telecom for their use under specified conditions is a breach of Section 106 of the Telecommunications Act, 2001.

- *This provision for "use under specified conditions" is typically applied to the cabling and wiring of commercial buildings, where the customer or building owner has special needs and does not necessarily subscribe to a Telecom wiring maintenance service. It covers the use of "RJ 12" and "RJ 45" socket-equipped jackpoints in such installations.*

- *Non-standard wiring maintenance contracts can generally be entered into by Telecom where commercial customers wish to have different types of cabling and jackpoints maintained*

(2) To offer non-Telepermitted products for sale to residential customers is likely to be in breach of the Consumer Guarantees Act, 1993, or the Sale of Goods Act, 1908, unless a clear warning is given to the purchaser to the effect that:

"This item has not been granted a Telecom Telepermit and shall not be connected to wiring connected to the Telecom network. Its use in such applications could lead to its being disconnected by Telecom and payment of a call-out charge".

- *"2-wire" BT socket-equipped jackpoints are subject to Telepermit requirements and a warning is required by the Consumer Guarantees Act to protect all residential and most business customers.*

- *This is partly due to the problem of ensuring high reliability in a residential environment and partly due to the wide range of styles and proprietary modules used.*

(3) The only current exceptions to this general rule are:-

(a) the RJ 45 8-way modular jackpoint used in commercial buildings and in the SOHO or “generic” cabling used in many new homes; and

(b) earlier “secondary” or “extension” type 3-wire jackpoints with six separate wiring terminations and six contact springs in the socket, to be used only in business system or data installations where four or more wires are necessary for their operation.

- *Where used in residential premises, such jackpoints are excluded from Telecom’s wiring and jackpoint maintenance service.*

(4) To ensure there is no doubt about their status, the use of earlier 3-wire “master” jackpoints on wiring connected to the Telecom network is no longer permitted.

5. LABORATORY TESTING AND DESIGN OF THE “2C” JACKPOINT

5.1 Testing requirements

(1) The non-availability of the ITT-Cannon socket, which had been made especially to Telecom’s enhanced plating requirements and specified in earlier versions of this Specification, led to the need to locate other socket suppliers and assess the corrosion resistance of their products. Having located the most promising option, a corrosion test regime was set up by Materials Processing & Technology Ltd, a specialist materials testing laboratory, in conjunction with the manufacturer of Telecom’s own jackpoints.

(2) The primary aim of these tests was to confirm that any component or design changes would be at least as corrosion resistant as Telecom’s own standard 2-wire jackpoint. Both standard jackpoints and various modified versions using the ITT-Cannon socket and the proposed replacement were simultaneously subjected to the same series of accelerated corrosion tests.

(3) This test regime was developed progressively in the light of preliminary results and a review of basic design requirements.

5.2 Outcome

(1) These tests resulted in the introduction of a socket with only 2-contact springs. As expected, omitting conductive components in the path between contact springs 2 & 5, which have 50 V between them while the line is “idle”, was proven to significantly reduce the leakage current under damp conditions. It is this leakage current which first triggers the corrosion process, eventually resulting in line lock-out and service disruption.

(2) Omitting the redundant contact springs and capacitor also allows omission of the associated copper tracks, such that the spacing between tracks with 50 V between them can be increased. This further reduces the risk of insulation breakdown across the surface of a damp printed circuit board.

5.3 Approved components and processes

(1) Details of the components approved by Telecom for use in jackpoint manufacture and contact details for these items are given in the Appendices. The socket supplier specified has undertaken to make this component available to any jackpoint manufacturer.

5.4 Qualification of other components

(1) While it is expected that most jackpoint manufacturers will make use of the specified socket, consideration will be given to the acceptance of other sockets. However, any such acceptance is subject to the supplier concerned arranging a similar series of comparative corrosion tests at their own cost.

(2) Since the actual testing process is the intellectual property of MPT a division of Industrial Research limited, it is not intended that the test regime be published by Telecom. Any supplier wishing to gain Telecom acceptance of other types of

socket will be required to arrange a comparative testing process with MPT and gain Telecom approval of this process before actual testing is carried out.

5.5 Designs other than that specified

- (1) While suppliers are invited to offer alternative components and processes for consideration by Telecom, no undertaking can be given that any such alternatives will be acceptable for Telepermit purposes.
- (2) Suppliers shall note that any design different to that shown in this specification and granted Telepermit by Telecom may have some aspects which are deemed to be the intellectual property of the supplier or manufacturer.
- (3) Where there is clear evidence that other components and processes can be expected to improve reliability, and there are no "intellectual property" issues, details of changes acceptable to Telecom will be added to the relevant Appendices.

6 JACKPOINT REQUIREMENTS

6.1 Component and process requirements

Based on almost 20 years experience covering the use of many millions of jackpoints and its recent laboratory testing, this specification defines components and processes that result in a high reliability product. The actual components and processes are specified later in this Section and in the attached Appendices.

6.2 Socket assembly

(1) All 2-wire jackpoints shall incorporate a socket assembly which accurately mates with a plug to BS 6312.

(2) Socket components of a brand and model listed in Appendix 1 of this Specification shall be used in all 2-wire jackpoints granted a Telepermit under the terms of this Specification.

- *Despite any apparent cost savings, there are good technical reasons to reject supplies of "equivalent items" from non-approved manufacturers. The integrity of the jack assembly is the key to long reliable service life and, for cover under a Telecom maintenance contract, Telecom is not willing to jeopardise reliability for minor savings in first cost.*
- *For example, the spring material used, the thickness of the nickel and gold plating applied to contact springs and the absence of cracking in the protective plating are not easily verified during an importer's inwards good inspections, so reputable suppliers are regarded as essential from a purely practical viewpoint.*
- *There are more than ten critical dimensions in the socket aperture to ensure the correct mating of the plug. The socket is like a complex lock in this respect and there is considerable risk that the tolerances in manufacturing the socket will not match with the tolerances in manufacturing the plug if the two items come from non-approved sources.*

6.3 Wiring terminations

(1) Standard square faceplate mounted 2c jackpoints shall incorporate two strips, each providing three insulation displacement connectors (IDC), such that up to three different conductor gauges may be used where necessary per line wire termination.

(2) Where two strips, each providing three insulation displacement connectors, are not practicable because of other design constraints, modular style 2c jackpoints shall incorporate an insulation displacement connector with at least two termination slots per line wire. In such cases, the spacing between the adjacent terminal slots shall be no less than 5 mm.

(3) For both options, (1) & (2), the IDC connectors shall be compatible with the Krone LSA-Plus insertion tool.

(3) For both options, (1) & (2), each IDC terminal slot shall be capable of terminating up to two wires of the same gauge for any gauge between 0.4 mm and 0.65 mm.

- *Telecom converted from 0.5 mm to 0.4 mm conductor cable in 1982, so both gauges may be in service in older installations. In some circumstances, 2-wire jackpoints will also be required to terminate 0.63 mm conductors.*

- *Potential suppliers should note that Telecom requires the use of insulation displacement connectors (IDC) as a safety measure and to avoid the risk of conductor damage should installers need to strip insulation - especially when 0.4 mm diameter wires are used.*

(4) Insulation displacement connectors of a brand and model listed in Appendix 1 of this Specification shall be used in all 2c jackpoints granted a Telepermit under the terms of this Specification.

6.4 Printed circuit board material

(1) A printed circuit board (PCB) meeting the requirements of ANSI/IPC-D-320 or an appropriate national equivalent in the country of origin shall form the mounting base for all jackpoint electrical components.

(2) Printed circuit boards shall be of an approved material of at least 1.5 mm thickness. The copper shall consist of high conductivity metal of minimum purity 99.5% and be free from wrinkles, pits, scratches, pinholes and blisters.

6.5 Protective coating materials or Protective Cover

When Protective Coating is chosen as the means of protecting the jackpoint from corrosion it must meet requirements (1) and (2) below:

(1) Protective coating of a brand and type listed in Appendix No. 1 of this Specification shall be used in all 2c jackpoints granted a Telepermit under the terms of this Specification.

(2) The coating used shall be suitable for application over the entire surface of the jackpoint. It shall be such that it will “scrape clean” only on the mating contact points wherever a wire or plug is inserted, but continue to provide a high level of protection from dampness or contamination on all other surfaces.

- *Conformal coatings of various types have been used in the past, but these provide no protection to the exposed contact springs and IDC connector springs. Also, unless measures are taken to prevent the conformal coating material entering the IDC connectors or socket assemblies, the application of such coatings may actually cause faults.*

When the Protective Cover is chosen as the means of protecting the jackpoint from excess dust and moisture, it must meet requirements (3), (4) and (5) below:

(3) The Protective Cover must fit onto the back of the 2c jackpoint; a possible design is given in Appendices figure 3.

(4) The intension of the Protective Cover is to stop dust and dirt falling onto the back of the jackpoint. This coupled with the inevitable water vapour would result in a build up of “grudge” on the back of the jackpoint due to air movement in the wall cavity. The increased gap between A & B leg contacts within the 2c jackpoint will substantially reduce corrosion probably making protective coating issues less important.

(5) If the Protective Cover is part of the jackpoint design then it must be impossible to install the jackpoint without the Protective Cover fitted. The Protective Cover must be complete with the “new features” given in the notes below Appendices Figure 3.

These are:



- No side or bottom knockouts to be fitted.
- 8 mm diameter cable entry holes to be located as shown in figure 3 to ensure cable entry at the bottom of the jackpoint assembly.
- Cable locating “pegs” used in the current Telecom design is now replaced by a 20 mm long “wall” to ensure that cables are kept below the printed circuit board and consequently water infiltrating within the cable sheath does not enter the space enclosed by the Protective Cover and jackpoint.

6.6 Solder

The solder used shall comply with BS 219 or a recognised equivalent specification.

6.7 Alternative components

- (1) While only the components or materials listed in Appendix 1 are currently acceptable to Telecom, this does not prevent a supplier seeking approval for any alternative components which offer significant benefit and can be shown to meet the requirements of this Specification.
- (2) Jackpoint reliability is a key aspect of the reliability and availability of Telecom’s services to its customers. As such, Telecom is interested in any proposals that can be expected to further improve reliability.
- (3) Where suppliers wish to have such alternatives accepted by Telecom, it is recommended that proposals be submitted prior to and separate from a Telepermit application. Such proposals shall include full supporting documentation, including any justification for their acceptance as permitted options.
- (4) Where any such components and processes are found to bring significant improvements in product reliability, they may be adopted as additional options or replacements for the components and processes listed in the current Appendices. Telecom encourages all suppliers to adopt improvements at the earliest opportunity.
 - *This edition of PTC 226 is an example of such a development.*
- (5) Where another brand or model of component has been accepted, it will be listed in Appendix 1 by means of an amendment to this Specification. This will generally mean that other suppliers will have the right to use the same component.

6.8 Installation instructions

- (1) To minimise customer confusion, suppliers of Telepermitted jackpoints shall provide simple installation instructions in each product pack. These instructions shall include suitable warnings on the need to avoid mixing types.
- (2) The instructions supplied with the jackpoint shall in no way conflict with Telecom Code of Practice PTC 103: 2005.

7 CONSTRUCTION AND MANUFACTURING PROCESSES

7.1 Interchangeability with Telecom mounting hardware

(1) Total interchangeability with current Telecom-supplied mounting hardware is not a mandatory requirement for the granting of a Telepermit.

(2) For suppliers who wish to ensure compatibility with current Telecom mountings, such that their hardware will be eligible for direct replacement under a Telecom residential wiring maintenance contract, the following data applies to the Telecom version:-

(a) The jackpoint printed circuit board and components to fit within a 46 mm diameter circle centred on the socket aperture.

(b) Square faceplates, of dimensions 67 mm +/- 0.1 mm overall, and manufactured in gloss white ABS plastic.

(c) Mounting holes are 51 mm +/- 0.1 mm apart and are designed for M3.5 machine screws.

7.2 Printed circuit board design and assembly

(1) IPC (previously known as Institute for Printed Circuits, www.ipc.org) practices and recommendations or any equivalents accepted by Telecom shall be complied with in the production of the printed circuit board assemblies.

(2) The classes of end product workmanship of the PCBs shall be stated.

(3) Maximum practicable separation shall be maintained between adjacent tracks or soldering on the printed circuit board. Simplicity of this 2c PCB means track spacing should exceed the previous minimum requirements for Jackpoint reliability.

• *Maximising the separation between tracks operating at different voltages is a major factor in reducing the probability of insulation breakdown in service. The 50 V d.c. line voltage is continuously applied between socket pins 2 and 5 and their associated copper tracks and terminations.*

(4) Solder pads for socket pins 1, 3, 4 and 6 shall be omitted.

(5) Copper tracks shall not be less than 2.0 mm in width.

• *It is preferred that 2 mm be maintained to provide a greater level of over-current capacity and improved track adhesion.*

(5) Terminal numbers may be clearly and permanently marked adjacent to each terminal position using the standard terminal number allocation shown in Fig. 1, or that same numbering may be moulded into the inner face of the faceplate in such a way as to be clearly visible to the installer.

(6) To ensure reliability in service, soldering of component leads on the printed circuit board shall be in accordance with IPC-S-815A, such that there is a continuous flow of

solder around the lead and between the lead and printed wiring. The end shape of the lead shall be clearly visible from the printed wiring side of the board.

7.3 Mechanical assembly

- (1) Clearance between support ribs in the rear of the faceplate and any solder joints on the printed circuit board shall be such as to avoid incorrect seating of the circuit board.
- (2) To avoid damage during plug insertion or snatch-out, the printed circuit board assembly shall be securely fastened to the faceplate.
- (3) All plastic mouldings shall be undistorted and present a flat mating surface with any associated mounting hardware.
- (4) Special attention shall be given to the seating of the IDC terminals against the printed circuit board. These components are subject to concentrated loads during installation and, if not seated properly, solder joint breakage or track peeling can result in premature service failure.
- (5) The socket assembly is to be seated securely against the surface of the printed circuit board with the mounting lugs securely welded to avoid the assembly breaking free during insertion of the plug or as a result of accidental snatch-out.
- (6) The socket opening shall be correctly aligned with the shutter aperture and have the top edge of the aperture in line with the top edge of the open cover to provide a guide for the plug to be inserted.
- (7) Alignment shall be such that the plug can be inserted and withdrawn without obstruction from the plastic mouldings.
- (8) The socket shall be clear of solder flux or any other extraneous material which prevents the free insertion and withdrawal of the plug.
- (9) The IDC strips shall be mounted with their "shoulders" facing the socket.

7.4 Cleaning

- (1) In the interests of long and reliable service, no corrosive residues shall be left on the printed circuit board following the soldering and any subsequent cleaning process.
- (2) Details of the cleanliness requirements are stated in Appendix No. 2. These shall be complied with for all jackpoints before any protective coating is applied.

7.5 Application of protective coating

- (1) The protective coating, as selected by the jackpoint manufacturer from the list of acceptable materials in Appendix No. 1, shall be applied in accordance with the specifications and recommendations provided by the manufacturer of that coating material.
- (2) Where "Acota TL6x" is to be used, this shall be applied in accordance with Appendix No. 3.

- *In typical installation situations in New Zealand, jackpoints may be subjected to continuous draughts within wall cavities, dusty conditions, and dampness during inclement weather conditions. There is thus a tendency for dust and dirt to accumulate on the printed circuit board and electrical components wherever a mounting box is left inadequately sealed. This can be even more of a corrosion risk where jackpoints are flush-mounted without the use of a substantially enclosed flush box.*
- *All line hardware is subjected to continuous 50 V d.c. from the network and frequent applications of 90V a.c. ringing signals. Both can lead to rapid insulation breakdown and corrosion should any ionic contamination be present in damp installations.*
- *It should be appreciated that where corrosion occurs in any socket or item of line terminating hardware the usual result is complete failure of service for the installation concerned. Corrosion almost invariably results in low insulation and progressively increasing leakage current which typically results in "one ring" faults. At this stage the line is unusable for incoming calls until the fault is located and repaired.*
- *Reliability is a primary requirement for the customer and for those involved in installing the product. As such, the suitability of a product to operate for many years in such environments is essential.*

(3) Handling precautions shall be taken during all further stages of manufacture and packaging to avoid rubbing the coating from the completed printed wiring assembly.

7.6 Faceplates and construction

(1) To keep its inventory to reasonable levels Telecom has adopted a basic range of jackpoint designs which, in conjunction with the appropriate form of mounting hardware, will meet the great majority of installation requirements. Nevertheless, there are now many additional designs available, providing such facilities as special panel mounting sockets, multiple outlets, and a variety of "decorator" features. Where such designs incorporate the standard BT socket and comply with the requirements of this Specification, they will be eligible for the grant of a Telepermit.

(2) The faceplate shall incorporate a dust shutter or cover which effectively seals the socket opening against dust or drafts when no plug is inserted.

- *A gravity or spring-loaded shutter or cover protects against the ingress of house dust or fluff into those sockets which are not fitted with a plug for long periods. The shutter also prevents insects from entering and possibly nesting in the socket aperture. As such, the shutter is a reliability requirement, not just a cosmetic feature.*

(3) The shutter or cover shall operate automatically when a plug is withdrawn.

- *Any effective design meeting the above requirements is acceptable for Telepermit purposes.*

(4) Faceplates may be manufactured in any suitable material, but metallic or conductive faceplates shall provide isolation from the Telecom line in accordance with the safety requirements of AS/NZS 60950.

(5) Special attention shall be given to the provision of printed circuit board supporting ribs in plastic mouldings. The use of insulation displacement terminals inherently involves the application of substantial forces during the termination of wiring. The plastic mouldings shall incorporate support ribs so designed that the circuit board is protected from flexure or fracture.

7.7 Mounting Boxes

(1) Telecom's own standard square format jackpoints are provided with covers to protect against damp, dust and other contaminants. Similar Mounting Boxes are recommended for adoption by other jackpoint suppliers with the introduction of the 2c jackpoint these Mounting Boxes are now considered a viable alternative to protective coating of the metallic pins of the jackpoint.

8 ENVIRONMENTAL REQUIREMENTS

8.1 Temperature and humidity

All jackpoints shall be able to perform their intended function over the temperature range -10°C to +40°C and 30% to 95% relative humidity.

8.2 Hydrogen sulphide

Some areas in New Zealand are subject to concentrations of H₂S in the atmosphere of up to 5 parts per million. Whether or not the jackpoint conforms to the following requirements shall be stated:

- (1) No lead stabilisers in any PVC materials.
- (2) No exposed copper or copper alloys in the components or printed circuit board assembly.

8.3 Construction

The mandatory components and materials accepted by Telecom and listed in Appendix No. 1 of this Specification are deemed by Telecom to be suitable for their purpose only as long as they are correctly assembled and processed in accordance with this Specification.

9 MOUNTING HARDWARE

9.1 General design issues

(1) Most residential installations in New Zealand are now using concealed wiring with surface-mounted Mounting Boxes. The most common version is that shown in Fig. 3.

(2) Experience to date has revealed that providing the cable access hole in the rear of the Mounting Box directly behind the socket could be a contributory factor in the more frequent socket corrosion found in this country.

- *It is likely that the usual ventilated timber-framed wall construction gives rise to damp air currents passing through the socket aperture. While this is not proven, there has been relatively high incidence of corrosion at the root of the socket springs.*

(3) In view of this possibility, it is recommended that cable knock-outs be provided in preference to cable access holes and that these are off-set from the centre.

- *Cable access holes located at the centre of the Mounting Box are not recommended.*

(4) The depth of the Mounting Box is not critical, but the box should be deep enough for cable to be led in from any angle and still provide clearance behind the jackpoint assembly when it is screwed into position.

(5) Where the physical size of a jackpoint design is different to that described in this Specification, the associated mounting should comply with the design principles outlined in this Section.

9.2 Dampness protection

Mounting hardware, shall be designed such that protection is provided against dampness on walls or in wall cavities.

- *As far as is practicable, the mounting should either hold the jackpoint from the surface of the wall or provide some form of drip seal to avoid condensation running into the socket or onto the surface of the printed wiring assembly.*

9.3 Dust and dirt protection

Mounting hardware shall provide protection against the ingress of dust and dirt which could lead to premature failure.

- *In this respect, the number and size of open cable access holes should be kept to a minimum consistent with adequate cable entry. Optional "knock-outs" are preferred, rather than holes and such knock-outs should not be located directly behind the socket.*

10. PRODUCT MARKINGS

10.1 Telecom Logo

Jackpoints offered for sale by parties other than Telecom shall not bear a “Telecom” logo without the express permission of Telecom.

10.2 Telepermit label

(1) Those jackpoints which have been granted a Telepermit shall bear the relevant Telepermit label, as defined by Telecom.

(2) The preferred Telepermit label format is shown in Fig. 4A. This label shall be used on those Telepermitted products which are intended to be covered by free replacements under Telecom's wiring maintenance service. This label provides space for the installer to mark the date of installation, as explained in Section 12. Other proposals for the Telepermit label format or means of meeting the warranty provision may be made by suppliers. Such alternatives shall be formally accepted by Telecom before they are put into use.

(3) Where the jackpoint is of a special type not able to be replaced by an identical Telecom item, the Telepermit label format shown in Fig. 4B shall be used.

(4) Where the supplier has a Telepermit, but is not willing meet the warranty criteria of Section 12, the Telepermit label format shown in Fig. 4C shall be used.

• *These labelling arrangements are intended to make the warranty provisions absolutely clear to customers, installers and service persons.*

10.3 Telepermit logo

(1) Those jackpoints which have been granted a Telepermit may bear the Telepermit logo in addition to the Telepermit label. Similarly, the Telepermit logo may be shown on any packaging or promotional material used for Telepermitted products.

(2) The Telepermit logo alone may be used as a replacement for the full details normally shown on the Telepermit label provided that the arrangement proposed is accepted by Telecom.

10.4 Terminal numbering

(1) In view of the “commoned” connector slots in standard format jackpoints it is not necessary to mark terminal numbers on printed circuit board.

(2) Where a single IDC strip is used on modular style jackpoints, the slots for each line wire shall be clearly marked.

(3) The socket pin numbers shall not be marked on the printed circuit board or on the faceplate.

• *Such numbering should be avoided because it is likely to cause confusion to an installer.*

10.5 Manufacturer's identification

(1) All products shall be permanently marked with a suitable code or logo to indicate either the maker's name and product or, where this is not pre-arranged on imported products, some indication of the name of the New Zealand importer and his product code.

- *This information is necessary for traceability of any products which prove to have an excessive fault rate during service.*
- *This information should preferably be in clear English text such that an end-user is aware of the origin of the product.*
- *Where it is not practicable to mark the above information in clear English, some form of unique code may be acceptable to Telecom.*

(2) Preferably, either the year and the number of the week on which the product was manufactured, or some form of batch number should also be shown.

(3) The above markings shall be shown at a suitable position on the actual jackpoint itself, usually on the inner surface of the faceplate, so as to be visible to an installer or service person without the need to dismantle the printed circuit board from the faceplate.

- *Markings may also be shown on the product wrapping if the supplier so chooses.*

(4) Type numbers, etc., may be combined with the "Telepermit" label once this has been granted. However, the space available is very limited.

(5) Easily-peeled labels shall not be used as permanent markings.

(6) The size and nature of the characters used for product marking is left to the discretion of the applicant, who should take into account the following factors:

- (a) Durability, legibility and visibility.
- (b) Materials to which the marking is applied.
- (c) Methods most suitable to the Manufacturer's plant and factory processes.

10.6 Faceplate marking

(1) All 2-wire jackpoints shall bear the legend "2c", permanently marked on either the exposed surface of the faceplate or the shutter to clearly indicate that the unit provides no ringing current for 3-wire connected CPE.

- *This type marking is required to permit rapid confirmation that all jackpoints used at an installation are of the 2-wire type. This allows easy recognition should the addition of any 3-wire jackpoints have resulted in "no ringing" faults being reported.*

(2) The "2c" should preferably be placed on the lower right hand corner of the faceplate and be moulded into the faceplate.

- *It is not critical which corner is used, but the lower right-hand corner is suggested for uniformity between suppliers.*

(3) The size and style of the “2c” is not critical, as long as it is clearly legible to customers and service staff.

- *The style used may be chosen by the manufacturer as part of brand identification.*
- *It is recommended that the “2c” be marked in 12-point or 14-point, within an inset square.*

10.7 Warnings and other consumer information

The product packaging and promotional material of any designs incompatible with those of Telecom shall incorporate clear warnings as regards Telecom's inability to provide identical replacements in the event of failure. Similarly, the product packaging and promotional material of any 2-wire jackpoints which are NOT covered by Telecom's wiring maintenance service shall provide warnings of this.

- Such warnings are necessary to comply with the Fair Trading Act 1986 and Consumer Guarantees Act 1993. Unless they are provided, these products could be purchased and installed without customers realising that they will be responsible for paying for replacements.

11 QUALITY ASSURANCE

11.1 Quality system

(1) To be granted a Telepermit for any item of terminating hardware, the manufacturer's quality standards shall be consistent with high reliability public communications equipment. The applicant shall therefore provide evidence to demonstrate that the manufacturer uses an effective system of quality assurance consistent with the requirements of this specification and is able to continuously control quality at the levels specified in the application for a Telepermit. This evidence involves the supply of the following additional information:

(2) The applicant shall submit:-

- (a) The manufacturer's quality plan for jackpoint production with full details of all procedures concerning quality assurance, and
- (b) Show evidence of any registration or acceptance of the factory's quality system by a recognised authority.

(3) For overseas manufacturers, information should be given regarding their acceptance as contractors or suppliers to any overseas telecommunications administrations, together with confirmation of such acceptability from the administrations concerned.

(4) Telecom reserves the right to carry out an audit of the manufacturer's quality control plan to ensure it meets the requirements of this specification. Such audits may take place prior to granting a Telepermit or at any other time should the service reliability of the jackpoints concerned be in question

11.2 Production consistency

Telepermit holders shall ensure that all products offered for sale continue to comply with the technical requirements laid down in this Specification and that the general conditions of PTC 100 are complied with.

11.3 Authorisation of changes

Where a Telepermit holder wishes to make changes to the product as accepted by Telecom, proposals shall be submitted to Telecom prior to making such changes, as required by clause 13.3. While any changes to the quality plan do not need to be advised to Telecom, Telecom shall, on request, be given a copy of the latest quality plan in the event that the service reliability of the jackpoints is in question.

11.4 Product traceability

Telepermit holders shall set up a system of marking batches and recording all production changes, including those not affecting compliance this is required in order to provide traceability should problems arise.

11.5 Quality monitoring

As outlined in PTC 100, Telecom reserves the right to regularly check on the quality of the goods offered for sale. Samples will be expected to comply with requirements of this specification, with the reference sample submitted at the time of application, and with the quality assurance data submitted by the applicant. If samples do not comply with the above, cancellation of the Telepermit and claims for damages against the supplier under the Telecommunications Act may result.

12 WARRANTY AND ONGOING SERVICING

12.1 Service reliability

Unlike almost all other Telepermitted products, jackpoints are interposed between the Telecom line and other CPE. The failure of a jackpoint directly affects the operation of the network service and the associated CPE. Several jackpoints per line are used in the typical New Zealand residential installation, and failure of any one of them can lead to a total service outage for the customer concerned. Poor reliability thus affects the customer, the supplier of “apparently faulty” CPE, and Telecom as the party responsible for restoring service.

12.2 Warranty

(1) Under the terms of its wiring maintenance service offered to residential and some business customers, Telecom has accepted the maintenance responsibility "in perpetuity" for those jackpoints which have been granted a Telepermit, whether or not they are supplied by Telecom. This acceptance was originally based primarily on the evidence submitted with the initial application and reliance on the manufacturer's assurance that only identical products of equivalent standard would be supplied.

(2) As one of the formal conditions for the grant of a Telepermit for 2-wire jackpoints, Telecom requires that applicants shall undertake some responsibility for the quality of the products they supply. Telecom will only continue to accept responsibility for those Telepermitted items used in residential applications if they have demonstrated a level of reliability under New Zealand service conditions comparable with that of Telecom's own jackpoints.

(3) As a demonstration of good faith and support for the products supplied, Telepermit holders shall provide an effective warranty system for all products sold for use in customer premises telecommunication wiring which is to be connected to the Telecom network.

(4) During a supplier's warranty period, a customer would normally return the faulty item to the retailer concerned, but this is impracticable in the case of jackpoints, as they are connected to the fixed wiring. Most customers simply report a fault to Telecom without knowing the cause. When Telecom service staff is on-site, they are expected to restore service. In the unlikely event that replacement of a jackpoint covered by the Telecom wiring maintenance service is required during the warranty period, they would use an equivalent Telecom jackpoint as a replacement.

(5) Where faulty products bear a Telepermit label showing that they are covered by Telecom's wiring maintenance service, Telepermit Holders shall agree to Telecom staff making replacements within the supplier's warranty period.

(6) The warranty shall provide for the payment of labour and material for the replacement by Telecom of any jackpoint which fails within six months from the date of installation in the customer's premises by an installer.

- *It is assumed that should any product prove unreliable and involve unacceptable support costs within the warranty period then the supplier will withdraw it from the market as quickly as possible or take the necessary remedial action.*

12.3 Warranty conditions

(1) With each of the jackpoints offered for sale with a Telepermit label, the Telepermit holder shall provide a warranty statement or other assurance in compliance with the Consumer Guarantees Act, 1993.

(2) Details of the applicant's warranty proposals shall be included in the formal application.

12.4 Ongoing servicing by Telecom

(1) In effect, jackpoint suppliers are entering into a relationship with Telecom whereby Telecom will repair or replace a faulty Telepermitted jackpoint as long as there is evidence that the product is reliable and of acceptable quality. There is thus a need to identify any jackpoint types not meeting these objectives. The only fair measure of reliability is a comparison of the product's failure rate with that of Telecom's own jackpoints made to this Specification. This implies the need to relate replacements to the number installed and to the time any faulty jackpoints have been in service.

(2) Suppliers gaining Telepermits for jackpoints to be covered by Telecom's wiring maintenance service shall provide 3-monthly reports to Access Standards on the number of jackpoints imported or manufactured. This information will be held in confidence by Access Standards.

(3) As part of a general service quality improvement programme, Telecom service staff is required to return all faulty 2-wire jackpoints found during service visits. These will be logged according to brand/model/time in service. In the event that Telecom service management considers a particular brand or model to have an excessive failure rate, they may choose to report the matter to Access Standards. The rate of replacements will be assessed by Access Standards using the statistics provided by suppliers under (2) above.

(4) Should a particular product prove to have a significantly higher failure rate than Telecom jackpoints manufactured to this Specification, Access Standards will advise the supplier concerned. Telecom reserves the right to withdraw or suspend a Telepermit until remedial action acceptable to Telecom has been taken.

(5) In addition, Telecom reserves the right to exclude from its maintenance service any further products of a type identified as in (4) above. Any such decision will be at Telecom's sole discretion.

13 SAMPLES AND DOCUMENTATION

13.1 Manufacturer Self-certification

(1) It is not practicable to test individual line hardware components because of the complexity of testing critical aspects such as gold plating thickness and contact spring material. This is why some critical components are subject to mandatory specification by Telecom.

(2) Notwithstanding Telecom's specification of such critical components, the jackpoint manufacturer is required to ensure that these materials, together with all other components and materials used in the manufacture of jackpoints supplied to the New Zealand market are subject to quality procedures described in the quality plan.

13.2 Samples

So that any inspection can readily ascertain whether future production is being maintained in accordance with the Telepermit application, applicants shall supply three samples of each item covered by that application. These samples will be retained for record purposes and comparison with subsequent production.

13.3 Design changes

Where design changes which are likely to affect the granting of a Telepermit are contemplated, applicants are referred to Specification PTC 100.

- *This Specification details Telecom requirements for formal acceptance of such changes.*
- *It should be noted that Telecom retains the original samples or drawings as references for use should there be any question about conformance with the original design.*

14 TESTING

14.1 Confirmatory testing

(1) Telecom reserves the right to make or arrange confirmatory tests of samples submitted in support of an application for a Telepermit. Such tests will generally only be carried out during the initial evaluation, but in the event of service problems additional tests may also be conducted in accordance with the conditions.

- *Such confirmatory testing may have to be carried out by a specialist laboratory, but any results will not be divulged to other outside parties.*

(2) Such confirmatory testing will in no way reduce Telecom's right under PTC 100 to carry out tests on products bearing a "Telepermit" label and offered for sale in New Zealand.

APPENDIX No. 1 Acceptable Components and Materials

This Schedule lists those components and materials which have been confirmed by Telecom to meet the objective reliability requirements of this Specification. As such, Telecom accepts that their use will permit the manufacturer of the jackpoint to comply with the mandatory materials clauses of this Specification.

Telecom reserves the right to add to or amend the following list in the light of service experience and future developments in the component and coating fields.

A1.1 Socket components

(1) The 2-contact versions of BT Jack manufactured by General Jack Co. Ltd, part number UK00G-6p2c are the ONLY “approved socket components” for 2c jackpoints at this time.

Contact details for orders are as follows:-

Telephone: +61 - 2 - 9997 8388
Fax: +61 - 2 - 9997 8699
Email: rsobanski@telequip.com.au
Website: <http://www.telequip.com.au>

(2) Telecom will accept NO other sockets until further notice. This particular make and model shall thus be used by all jackpoint manufacturers in order to qualify for the grant of a Telepermit under the terms of this Specification.

A1.2 Insulation displacement connectors

(1) Krone 3-way LSA-Plus IDC connector, Part No. 6048 1 001-03;

(2) For modular type jackpoints only, genuine Krone 4-way LSA-Plus IDC connector, Part No. 6048 1 001-04;

(3) Genuine Pressac “KATT” style IDC terminations, formally recognised by BT as Strip 238A.

(4) General Jack IDC terminations, Part No. T39A.

A1.3 Protective coating material

The only coating product now approved by Telecom for use in jackpoints is Certonal “TL6X”, as manufactured by Acota Ltd and applied as specified in Appendix No. 3

Certonal identification and ordering: Certonal is supplied in glass bottles, each containing 5.5 kg (approximately 3.5 litres) or alternatively steel drums containing 25 kg (15.6 litres)

Sales: Description for the glass bottle is: Certonal 5.5kgs blue dye 2% solids TNZ. Its part number is abbreviated to: CERT-2.0-BD-5.5-TNZ.

Description for the steel drum is: Certonal 25kgs blue dye 2% solids TNZ. Its part number is abbreviated to: CERT-2.0-BD-25.0-TNZ.

30-36 Old Coleham
Shrewsbury
Shropshire SY3 7BU
ENGLAND

Tel: +441-743 244411
Fax: +441-743 289658
E-mail: sales@acota.co.uk

Support: Much information is published at <http://www.acota.co.uk> This has replaced the former <http://www.layton.co.uk> Direct English language support is available to Certonal customers from Steve Henly of Acota by phone or fax at the same numbers as above.

Purpose built coating plant that assures excellent results for minimum Certonal usage, is also available.

Telecom currently accepts NO other protective coating material. Until further notice, this material shall thus be used by all jackpoint manufacturers in order to qualify for the grant of a Telepermit under the terms of this Specification.

APPENDIX No. 2: Cleaning Requirements for Printed Wiring Assemblies

A2.1 Post soldering cleaning

- (1) Printed wiring assemblies (PWA's) complete with all components soldered in place shall be cleaned no later than 60 minutes after completion of soldering using solvents or combinations of solvents or other solutions which will remove all polar and non-polar contaminants.
- (2) Cleaning shall have no deleterious effects on any part of the printed wiring assembly.
- (3) After cleaning, PWA's shall not be contaminated by handling or environment prior to coating. If the option for protecting the PWAs is Protective Covers, then they must not be handled (by people) after cleaning.
- (4) Hand soldering rework shall be minimised by appropriate control of the machine soldering process. Such rework should be completed prior to cleaning within the time specified in (1) above. Exceptionally, when necessary following cleaning and coating, hand soldering shall use non-activated rosin flux and no subsequent cleaning or coating shall be attempted.

A2.2 Cleanliness

- (1) After cleaning, there shall be no visual evidence of flux residue or other contamination. "Other contamination" includes particles of foreign matter which may result in insulation breakdown or change in electrical characteristics or degradation of mechanical integrity (e.g. improper bonding of the coating).
- (2) When tested in accordance with A2.3 and sampled in accordance with A2.4, PWA's shall have ionic contamination not greater than an equivalent Sodium Chloride contamination of $1.55 \mu\text{g per cm}^2$ when measured to MIL-P-28809. Sodium Chloride equivalents are given below in Table A2.2.

A2.3 Cleanliness test

- (1) Complete and cleaned PWA's shall be washed in a solvent, the resistivity of which shall be measured.
- (2) The specific test methods and equivalence factors apply to the various commercial instruments available. The test procedure specified by the instrument manufacturer shall be followed and the acceptance limit applied shall be as follows in Table A2.1.
- (3) An example of a typical test procedure is outlined in A2.7

Table A2.1 Equivalence Factors for Testing Ionic Contamination

Method	Equivalence Factor	$\mu\text{gNaCl}/\text{cm}^2$	$\mu\text{gNaCl}/\text{in}^2$
MIL-P-28809 Beckman	1	1.56	10
MIL-P-28809 Markson	1	1.56	10
Omega Meter Model 200	1.39	2.2	14
Ionograph	2.01	3.1	20
Ion Chaser	3.25	5.1	32
Zero Ion Model ZI-100	3.83	5.8	37

A2.4 Inspection lot for cleanliness verification

(1) An inspection lot for cleanliness verification shall consist of all PWA's processed through the cleaning process during a single production shift.

(2) Immediately after cleaning, the last five PWA's per production shift shall each be subjected to the test of table A2.2.

(3) Relaxation of this requirement will be authorised by Telecom only on production of evidence that control of the cleaning process is sufficient to justify less frequent testing.

A2.5 Failed batches

(1) Failure of any assembly to pass the test constitutes a failed test.

(2) To minimise disruption to production flow, the manufacturer's Quality Manager shall investigate the relevant data and circumstances. If satisfied that reliability of the final product is not impaired, the batch involved may be completed and delivered.

(3) In no circumstances shall jackpoints that have been coated, be recoated.

(4) Should the circumstances indicate that reliability may be compromised, and the batch concerned has proceeded beyond coating, that batch shall be withdrawn and destroyed. Where coating has not been completed, re-cleaning and re-testing may be undertaken. However, more aggressive cleaning may be required, particularly if rosin based flux has been used.

(5) Jackpoints of batches for which cleanliness test results have not been received, shall not be delivered.

(6) All cases of failed test shall be reported in the monthly summary sent to Telecom, together with the cause and remedial action taken to prevent reoccurrence.

(7) Relaxation of the frequency of cleanliness tests in terms of A2.4 (3) above shall revert to batch by batch testing.

A2.6 Rejected lots

When a lot is rejected as a result of a failure to pass the test specified in table A2, the manufacturer shall withdraw the lot, take corrective action in connection with the cleaning materials and procedures, re-clean the lot, and resubmit the lot to the test of table A2. Such lots shall be separated from new lots, and shall be clearly identified as re-inspected lots.

Table A2.2 In-Process Inspection

Test or inspection	Requirement paragraph	Method paragraph	Sampling plan
Cleanliness and resistivity of solvent extract	A2.2	A2.3	A2.4

A2.7 Typical cleanliness test procedure

(1) Prepare a test solution of 75 percent by volume ACS reagent grade isopropyl alcohol and 25 percent by volume distilled/deionised water. Pass this solution through a mixed bed deionizer cartridge (Barnstead D8902, Ultra-Purse, Hose-Nipple Cartridge, or equal). After passage through the cartridge, typical resistivity of the solution will be 25×10^6 ohm-cm. Replacement of the deionizer cartridge shall be required when the resistivity of the solution is of value less than 6×10^6 ohm-cm. Replacement of the solvent extract solution shall be required when the resistivity of the solution is of a value less than 2×10^6 ohm-cm.

(2) Position a convenient sized polyethylene funnel over a suitable polyethylene container. Premark the container for the volume of test solution required for the test. Suspend the printed wiring assembly within the funnel.

(3) Direct the test solution, in a fine stream, on to both sides of the assembly until 10 ml of test solution is collected for each square inch of assembly area. Assembly area includes the area of both sides of the board plus an estimate of the area of the components mounted thereon. Wash the assembly for a minimum of 1 minute. It is imperative that the initial washings be included in the test sample. Measure the resistivity/conductivity of the collected test solution with a conductivity bridge or other instrument of equivalent range and accuracy.

(4) All laboratory ware must be scrupulously clean. Preferably, laboratory ware used for this test should be reserved for this test and not used elsewhere. Alternate test methods specified in A2.3 may be used.

APPENDIX No. 3 Coating Requirements for Printed Wiring Assemblies

Only the coating material specified in Appendix 1 shall be used. This Appendix provides details of the coating processes acceptable to Telecom.

A closed tank coating process is recommended. Information and equipment is Jackpoint manufacturers should contact Acota Ltd, the supplier of Certonal for the latest recommendations on the coating process.

The following information outlines requirements which apply to the more common open tank dipping process.

A3.1 Dipping requirements

(1) The tank shall be stocked with sufficient undiluted "as shipped" Certonal to totally submerge completed, cleaned and dried PC assemblies.

(2) Prior to coating, the printed circuit assemblies shall be thoroughly dried in accordance with A2.8.

(3) Where made up on a panel of multiple assemblies, each shall be separated such that the coating will cover all cut edges of each circuit board as well as all components and both board surfaces.

(4) The mechanism that submerges the assemblies shall keep assemblies separate from each other. The complete assemblies shall not touch each other while submerged, during withdrawal or during subsequent drying.

(5) Agitation shall be provided to ensure that all trapped air is dispelled while submerged. Acota recommends ultrasonic fluid agitation at 38 to 42 kHz.

(6) Assemblies shall remain totally submerged for at least 30 seconds following total displacement of trapped air.

(7) Withdrawal shall be slow and steady without shock. Mechanised withdrawal at a rate not exceeding 100 mm/sec and that also avoids sudden acceleration and deceleration, is recommended.

A3.2 Drying and thereafter

(1) Following withdrawal, the assemblies shall be allowed to drain and dry naturally without touching each other, and with no shaking, air-wipe or the like.

(2) After drying, the assemblies shall be handled and transported with care to ensure that the coating film is not damaged.

(3) At all subsequent stages - e.g., final assembly and packing, protection of the coating from abrasion is essential.

(4) The nature of the dried film is such that it is removed from the contact surface of the jack springs, merely by insertion of a plug. An equivalent force will

unacceptably remove the film from any other parts. Particular care shall be taken when fitting PC assemblies to faceplates.

A3.3 Dipping tank maintenance

- (1) Refrigeration above the surface is acceptable to minimise evaporation of solvent. Care is needed to ensure that dew does not form on the Certonal surface.
- (2) Water or any other liquid shall NOT be floated on top of the Certonal surface to prevent loss by evaporation.
- (3) Dipping tank contents shall be regularly maintained between 1.7% and 2.2% solids content, by weight.
- (4) High % solids may be corrected by carefully mixing Certonal TLS solvent into the contents.
- (5) Low % solids may be corrected by replacing the tank contents with new Certonal, or carefully evaporating solvent off using a tank temperature of 40°C. Acota can reprocess low % solids Certonal to new condition.
- (6) Acota recommends % solids content verification as follows:
 - a) Use accurate balance capable of measuring to 0.001g (1 mg).
 - b) Calibrate balance as required.
 - c) Weigh a 10cc syringe and watch glass - record weight "A".
 - d) Extract approximately 5cc of fluid in syringe and re-weigh with watch glass - record weight "B".
 - e) Dispense fluid into watch glass and allow it to fully evaporate, do not heat above 80°C if using heat to evaporate solvent.
 - f) Once the fluid has fully evaporated (and the watch glass has cooled if necessary) re-weigh the syringe and watch glass - record weight "C".
 - g) Deduct "A" from "B" = weight of fluid.
 - h) Deduct "C" from "A" = weight of solid.
 - i) $\text{Weight of solid divided by weight of fluid} \times 100 = \text{percentage of solids present in fluid.}$
 - j) The value should be no less than 1.7% and no higher than 2.2%. Use Certonal TLS solvent to reduce solids content if necessary.

APPENDIX No. 4: Summary of Documentation to be Submitted

NOTE: The following information is to be submitted for each type of jackpoint for which a Telepermit application is being made. The same format should preferably be used.

APPLICANT COMPANY

.....

MANUFACTURER'S NAME
AND ADDRESS

.....

.....

.....

PRODUCT NAME/BRAND
(As offered for sale in NZ)

.....

PRODUCT IDENTIFICATION

.....

CODE NUMBERS

DRAWING/SPEC NO.
OF ITEM SUPPLIED

.....

DRAWING/SPEC SUPPLIED

YES / NO

TYPE OF SOCKET COMPONENT

.....

(where applicable)

SOCKET MANUFACTURER

.....

TYPE OF IDC CONNECTOR

.....

IDC MANUFACTURER

.....



NOTE THAT THE ABOVE DOCUMENTATION IS TO BE SUPPLIED WITH THE APPLICATION

Warranty proposals provided YES / NO

Samples provided with application YES / NO

IS THIS JACKPOINT TO BE COVERED BY THE TELECOM WIRING MAINTENANCE SERVICE? YES / NO

I UNDERTAKE TO COMPLY WITH THE CONDITIONS PUBLISHED IN THIS SPECIFICATION AND THE GENERAL CONDITIONS PUBLISHED IN PTC 100, ESPECIALLY AS REGARDS THE WARRANTY AND ANY NECESSARY PRODUCT WARNINGS

I CERTIFY THAT THE ABOVE DETAILS APPLY TO THE ENTIRE ABOVE-DESCRIBED PRODUCT WHICH IS TO BE OFFERED FOR SALE IN NEW ZEALAND AND FOR WHICH THIS TELEPERMIT APPLICATION IS MADE.

I ALSO UNDERTAKE TO ENSURE THAT NO DESIGN CHANGES AFFECTING THE GRANT OF THE TELEPERMIT WILL BE MADE WITHOUT TELECOM APPROVAL.

I am authorised by the Applicant company to make these undertakings

Signed

Position in Company

Company Name

Date



APPENDIX No. 5 Telepermit Assessment Schedule

A5.1 General

The final stage of the Telepermit assessment process is carried out on 10 samples taken at random from the first production run. The schedule of requirements is effectively a checklist which applicants should aim for when a product is first contemplated. It is expected that information will be supplied during development, and by the time the production samples are submitted most of the assessment will have been already completed.

Assessment is divided into five categories:

- (1) Design assessment
- (2) Component assessment
- (3) Manufacturing Process
- (4) Installation Instruction assessment
- (5) Marking and Labelling requirements

In the case of design assessment, it has not been possible to date to devise a laboratory test which can be used as a definitive test of the long-term reliability of a jackpoint. There is therefore a degree of subjectivity in assessing this aspect. Where the design differs from the Telecom reference design, but does not have obvious weaknesses, and complies with other basic requirements, an interim Telepermit will be granted. This will allow the product to be installed under a wide range of service conditions. Should the product exhibit a significantly higher rate of failure than the Telecom reference design, or be found to fail consistently through one mechanism, remedial action will be required.

For reliability assessment, the test sample will be compared with the Telecom Reference Design as a complete unit. The most likely failure mode of the sample will be compared with the most likely failure mode of the Telecom Reference Design. It is likely that an alternative design will contain some elements which are superior as well as some elements which are inferior to the Telecom Reference Design.

Where copies of manufacturer's statements of compliance of other documentation is required, the requirement in this schedule is prefixed by ~ This information would normally be provided to Telecom Access Standards during the prototype development phase.

The applicant is invited to use the following schedule, as a checklist of the requirements of this specification. It summarises the assessment criteria used by Telecom in evaluating a jackpoint Telepermit application

A5.2 Design

Design equivalent to Telecom Design: Yes/No
 If yes go to A5.5, if no go to A5.3

A5.3 Corrosion resistance

- (1) equivalent to Reference design Complies/Does not comply/Trial
 (2) Satisfactory shutter arrangement Complies/Does not Comply

A5.4 Reliability of wiring

Complies/does not comply/Trial

Design (A5.2, A5.3, & A5.4) Complies/Does Not Comply/Trial

A5.5 Components**A5.5.1 Sockets**

- (1) Mates with BS 6312 plug Complies/Does not Comply
 (2) (a) Socket specifically approved by Telecom Yes/No
 If yes go to A5.5.2, if no go to A5.5.1 (2)(b)
 * (b) Evidence of BT licence Complies/Does not Comply
 (3) Plating thickness 2 µm gold over 3 µm nickel
 over full surface of contact spring
 * (certificate of compliance from manufacturer) Complies/Does not Comply

Socket Assessment

Complies/Does Not Comply/Trial

A5.5.2 Wiring terminations

- (1) IDC connector listed in Appendix 1 Yes/No
 If yes go to A5.5.3, if no go to A5.5.2(2)
 (2) IDC Connector compatible with Krone
 tool or can be used without tool Krone tool/No Krone tool
 (3) IDC connector capable of terminating
 two same gauge wires between 0.4 mm
 and 0.63 mm. (certificate of compliance
 from manufacturer and confirming test) Complies/Does not Comply
 (4) Indemnification if connectors similar to
 Krone, but not manufactured under
 a Krone license. Complies/Does not Comply/NA

Wiring Termination Assessment**Complies/Does Not Comply****A5.5.3 Printed Circuit Board**

(1) Printed Circuit Board Used
If yes go to A5.5.3(2) if no go to A5.5.4

Yes/No

(2) (a) Printed Circuit Board Material

.....

(b) Meets requirements of
ANSI/IPC-D-320 or equivalent

Complies/Does not Comply

(3) Thickness of PCB (> 1.5 mm)

..... mm

Complies/Does not Comply

(4) Minimum Track spacing

(>3.0 mm)

..... mm

Complies/Does not Comply

(5) Track Width

(>2 mm, <3 mm)

..... mm

Complies/Does not Comply

(6) No exposed bare Copper tracks

Complies/Does Not Comply

Printed Circuit Board**Complies/Does Not Comply/NA****A5.5.4 Protective coating**

Protective coating material listed
in Appendix 1 (manufacturers statement
of compliance)

Yes/No

if no, evidence will need to be supplied
showing that alternatives give a similar
level of protection.

Either Protective coating**Complies/Does Not Comply****Or Protective Cover****Complies/Does Not Comply**

(a) Protective Cover meets telecom design

Yes/No

(i) No side or bottom knockouts fitted?

Yes/No

(ii) Cable entry located at the bottom
of the Protective Cover?

Yes/No

(iii) 20mm “wall” to stop cable sheath rising above the PCB? Yes/No

(b) Jackpoint cannot be installed in wall cavity without Protective Cover installed Yes/No

A5.5.5 Solder

(a) Meets BS219 (manufacturer’s statement of compliance) Complies/Does Not Comply

(b) Meets equivalent to BS219 if applicable (state equivalent)

Solder Complies/Does Not Comply

Components (A5.5)	Complies/Does Not Comply/Trial
-------------------	--------------------------------

A5.6 Construction and Manufacturing Process

A5.6.1 Interchangeable with Telecom mounting hardware Yes/No

A5.6.2 Mechanical Assembly

(1) PCB seated evenly Complies/Does Not Comply/NA

(2) Socket/PCB assembly firmly fastened to faceplate Complies/Does Not Comply

(3) Even mating between faceplate and mounting hardware Complies/Does Not Comply

(4) IDC connector supported to meet loads from installation tool (If PCB used, IDC must be evenly seated on PCB and PCB must be supported) Complies/Does Not Comply

(5) Alignment of socket and faceplate satisfactory Complies/Does Not Comply

Mechanical Assembly Complies/Does Not Comply



A5.6.3 Cleaning

(1) Visual inspection shows no residues Complies/Does Not Comply

* (2) Manufacturer's Statement of Compliance that cleaning procedures are in accordance with Appendix 2 Complies/Does Not Comply

Cleaning Complies/Does Not Comply

A5.6.4 Application of protective coating

* Manufacturer's Statement of Compliance that application of the protective coating is in accordance with Appendix 3

Application of protective coating Complies/Does Not Comply

Manufacturing Process (A5~6)	Complies/Does Not Comply
-------------------------------------	---------------------------------

A5.7 Product Markings

(1) Telepermit Label Complies/Does Not Comply

(2) Terminal numbering Complies/Does Not Comply

(3) Manufacturer's Identification Complies/Does Not Comply

(4) Manufacturer's Batch Code Complies/Does Not Comply

(5) 2-wire jackpoint identification '2c' (visible when installed) Complies/Does Not Comply

(6) Installation date label Complies/Does Not Comply

(6) Permanence of label Complies/Does Not Comply

(7) Packaging

(a) Telepermit Label Clearly visible Complies/Does Not Comply

(b) "2-wire 2 contact" 2c clearly visible Complies/Does Not Comply

(c) Warning to purchasers that product not for use in 3-wire installations Complies/Does Not Comply

(d) Package labelling match product markings which in turn match Telepermit Register details Complies/Does Not Comply

Product Marking (A5.7)	Complies/Does Not Comply
-------------------------------	---------------------------------

A5.8 Installation instructions

A5.8.1

Are Telecom standard instruction sheets to be packed with product Yes/No

Information to be contained

- | | |
|--|--------------------------|
| (1) Product to be maintained by Telecom or not | Complies/Does Not Comply |
| (2) All joints to be made at jackpoint | Complies/Does Not Comply |
| (3) Wiring to come from below socket | Complies/Does Not Comply |
| (4) Consumer Guarantees Act information | Complies/Does Not Comply |
| (5) Electrical Safety Information | Complies/Does Not Comply |

Installation instructions (A5.8) Complies/Does Not Comply

OVER ALL ASSESSMENT	COMPLIES / DOES NOT COMPLY/ TRIAL
----------------------------	--

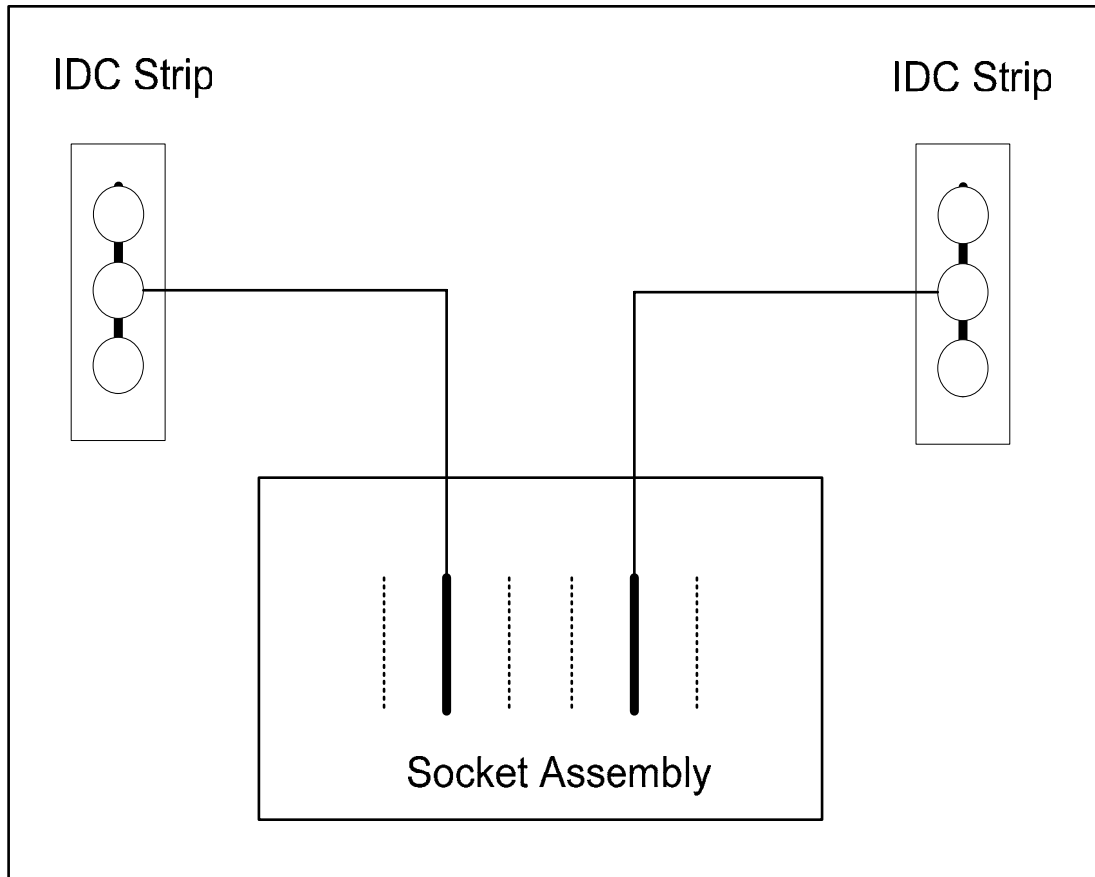
APPENDIX No. 6:- Diagrams Relating to the 2c Jackpoint**Please Note:**

1. Dotted lines indicate unequipped pins.
2. There is no equipped capacitor

**Appendix 6: Diagram No. 1 Entitled:
Circuit Diagram for 2c Jackpoint**

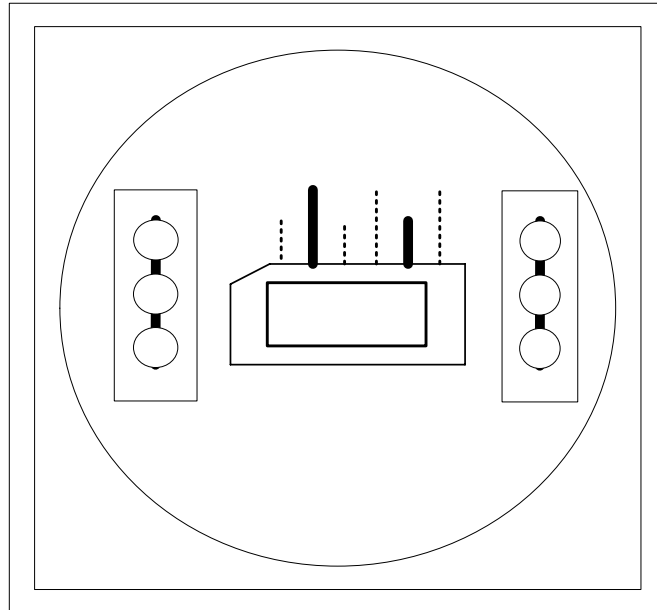

Component Side of Jackpoint

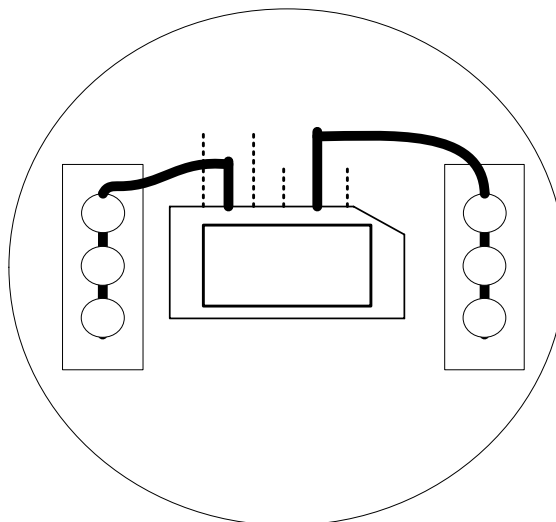

Printed Circuit Side of Jackpoint

Notes about construction:

1. 3 slots on each terminal strip are common allowing the use of up to 3 different wire gauges.
2. Dotted lines indicate unequipped pins.
3. No equipped capacitor

Explanatory Notes:

1. The drawn printed circuit tracks are explanatory only to show that track spacing is no longer an issue.
2. The drawing is not intended to show an actual design for compliance.
3. The shoulders of the IDC strip face to the centre.

**Appendix 6 Diagram No. 2 Entitled:
Typical Physical Layout of a Telecom 2c Jackpoint**

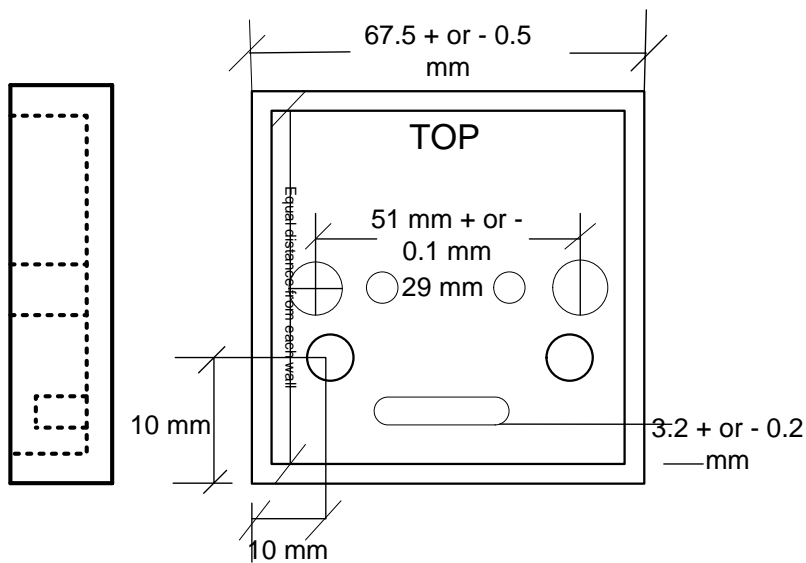
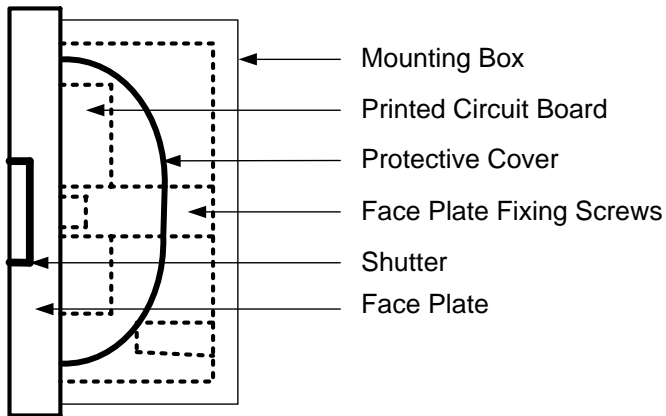

Notes:

Material: Gloss White ABS, wall and base thickness 2 mm
 Brass faceplate mounting inserts to be threaded M3.5

Features Box mounting via 4 mm dia hole and 6x4 mm slot

1. No side or bottom knockouts are to be provided.
2. Cable entry holes to be located as shown to ensure cable entry at the bottom.
3. A 20 mm long "wall" is located as shown to ensure that cables are kept below the printed circuit board
4. If the Protective Cover option is being supplied then it needs to completely cover the printed circuit board as shown. It must not be possible to install the jack point without the protective cover fitted.

Appendix 6 Diagram No. 3 Entitled: Mounting Box and Protective Cover



FIG. 4A STANDARD TELEPERMIT LABEL FOR PRODUCTS COVERED BY TELECOM WIRING MAINTENANCE



FIG. 4B TELEPERMIT LABEL FOR SPECIAL DESIGNS COVERED BY TELECOM WIRING MAINTENANCE, BUT NOT DIRECTLY REPLACEABLE



FIG. 4C TELEPERMIT LABEL FOR SPECIAL DESIGNS NOT COVERED BY TELECOM WIRING MAINTENANCE SERVICE

NOTES

1. The amount of space available for label details is limited by the size of the product and the very restricted space around the printed wiring assembly, hence the reduced product information.
2. The supplier may choose to include the manufacturer's brand name on the label
3. Note that "shoulders" of DC strips face to the centre.

FIG. 4 TELEPERMIT LABEL FORMATS

Appendix 6 Diagram Number 4 Entitled:
Telepermit Label Formats