



## **Specification PTC 331**

### **Telephone Network Interconnection using ITU-T No. 7 Signalling**

#### **PART C**

#### **ISUP SPECIFICATION**

##### **Recommendation Q.763**

##### **MESSAGE AND PARAMETER FORMATS AND CODES**

**and**

##### **Recommendation Q.764**

##### **SIGNALLING PROCEDURES**

(This page intentionally blank)

## CONTENTS

Section	Title	Page C- .
<b>0</b>	<b>Introduction</b>	<b>5</b>
0.1	Scope	5
0.2	Relationship with ITU-T Recommendations	5
0.3	General	6
0.4	Interworking with non-ISUP signalling systems	6
0.5	ISUP-ISUP interworking at the Telecom POI exchange	6
0.6	Changes from Issue 1	7
<b>1</b>	<b>General</b>	<b>7</b>
1.0	Scope, references, definitions, abbreviations	7
1.0.1	Scope	7
1.0.2	References	7
1.0.3	Terms and definitions	8
1.0.4	Abbreviations	8
1.0.5	General coding principles	9
1.1	Routing label	10
1.2	Circuit identification code	10
1.3	Message type code	11
1.4	Formatting principles	13
1.5	Mandatory fixed part	14
1.6	Mandatory variable part	14
1.7	Optional part	14
1.8	End of optional parameters octet	14
1.9	Order of transmission	14
1.10	Coding of spare bits	15
1.11	National message types and parameters	15
1.12	Rules for the allocation of message types codes and parameter name codes	16
1.13	Meaning of "spare" codes and "reserved" codes	16
<b>2</b>	<b>Parameter formats and codes</b>	<b>16</b>
2.1	Message type codes	16
2.2	Coding of the length indicator	16
2.3	Coding of the pointers	16
<b>3</b>	<b>ISDN user part parameter</b>	<b>17</b>
3.1	Parameter names	17
3.2	Access delivery information	19
3.3	Access transport	20
3.4	Automatic congestion level	21
3.5	Backward call indicators	21
3.6	Call diversion information	24
3.7	Call history information	24
3.8	Call reference (national use)	24
3.9	Called party number	25
3.10	Calling party number	27

3.11	Calling party's category	29
3.12	Cause indicators	32
3.13	Circuit group supervision message type	46
3.14	Circuit state indicator (national use)	47
3.15	Closed user group interlock code	47
3.16	Connected number	47
3.17	Connection request	47
3.18	Continuity indicators	47
3.19	Echo control information	47
3.20	End of optional parameters	47
3.21	Event information	47
3.22	Facility indicator	48
3.23	Forward call indicators	48
3.24	Generic digits (national use)	51
3.25	Generic notification indicator	51
3.26	Generic notification indicator	51
3.27	Reserved (used in 1992 version)	51
3.28	Information indicators (national use)	51
3.29	Information request indicators (national use)	51
3.30	Location number	51
3.31	MCID request indicators	51
3.32	MCID response indicators	51
3.33	Message compatibility information	51
3.34	MLPP precedence	51
3.35	Nature of connection indicators	51
3.36	Network specific facility (national use)	52
3.37	Optional backward call indicators	52
3.38	Optional forward call indicators	54
3.39	Original called number	54
3.40	Origination ISC point code	55
3.41	Parameter compatibility information	55
3.42	Propagation delay counter	55
3.43	Range and status	55
3.44	Redirecting number	57
3.45	Redirection information	58
3.46	Redirection number	60
3.47	Redirection number restriction	60
3.48	Remote operations (national use)	60
3.49	Service activation	60
3.50	Signalling point code (national use)	61
3.51	Subsequent number	61
3.52	Suspend/resume indicators	61
3.53	Transit network selection (national use)	62
3.54	Transmission medium requirement	62
3.55	Transmission medium requirement prime	63
3.56	Transmission medium used	63
3.57	User service information	63
3.58	User service information prime	64
3.59	User teleservice information	64

<b>3.60</b>	<b>User-to-user indicators</b>	<b>64</b>
<b>3.61</b>	<b>User-to-user information</b>	<b>65</b>
<b>3.62</b>	<b>Backward GVNS</b>	<b>65</b>
<b>3.63</b>	<b>CCSS</b>	<b>65</b>
<b>3.64</b>	<b>Call transfer number</b>	<b>65</b>
<b>3.65</b>	<b>Call transfer reference</b>	<b>65</b>
<b>3.66</b>	<b>Forward GVNS</b>	<b>66</b>
<b>3.67</b>	<b>Loop prevention indicators</b>	<b>66</b>
<b>3.68</b>	<b>Network management controls</b>	<b>66</b>
<b>3.69</b>	<b>Circuit assignment map</b>	<b>66</b>
<b>3.70</b>	<b>Correlation id</b>	<b>66</b>
<b>3.71</b>	<b>SCF id</b>	<b>66</b>
<b>3.72</b>	<b>Call diversion treatment indicators</b>	<b>66</b>
<b>3.73</b>	<b>Called IN number</b>	<b>66</b>
<b>3.74</b>	<b>Call offering treatment indicators</b>	<b>66</b>
<b>3.75</b>	<b>Charged party identification (national use)</b>	<b>66</b>
<b>3.76</b>	<b>Conference treatment indicators</b>	<b>66</b>
<b>3.77</b>	<b>Display information</b>	<b>66</b>
<b>3.78</b>	<b>UID action indicators</b>	<b>66</b>
<b>3.79</b>	<b>UID capability indicators</b>	<b>66</b>
<b>3.80</b>	<b>Hop counter</b>	<b>66</b>
<b>3.81</b>	<b>Collect call request</b>	<b>67</b>
<b>4</b>	<b>ISDN user part messages and codes</b>	<b>67</b>
<b>4.1</b>	<b>General</b>	<b>67</b>
<b>4.2</b>	<b>Address Complete Message</b>	<b>67</b>
<b>4.3</b>	<b>Answer</b>	<b>68</b>
<b>4.4</b>	<b>Call Progress (CPG)</b>	<b>69</b>
<b>4.5</b>	<b>Circuit Group Query Response (CQR)</b>	<b>70</b>
<b>4.6</b>	<b>Circuit Group Reset Acknowledgement</b>	<b>71</b>
<b>4.7</b>	<b>Confusion (CFN)</b>	<b>71</b>
<b>4.8</b>	<b>Connect Message (CON)</b>	<b>71</b>
<b>4.9</b>	<b>Continuity (COT)</b>	<b>72</b>
<b>4.10</b>	<b>Facility Reject (FRJ)</b>	<b>72</b>
<b>4.11</b>	<b>Information (INF)</b>	<b>72</b>
<b>4.12</b>	<b>Information Request (INR)</b>	<b>72</b>
<b>4.13</b>	<b>Initial Address Message (IAM)</b>	<b>73</b>
<b>4.14</b>	<b>Release (REL)</b>	<b>74</b>
<b>4.15</b>	<b>Release Complete (RLC)</b>	<b>75</b>
<b>4.16</b>	<b>Subsequent Address Message (SAM)</b>	<b>76</b>
<b>4.17</b>	<b>User-to-User Information (USR)</b>	<b>76</b>
<b>4.18</b>	<b>Delayed Release (DRS)</b>	<b>76</b>
<b>4.19</b>	<b>Forward Transfer (FOT)</b>	<b>76</b>
<b>4.20</b>	<b>Suspend (SUS)</b>	<b>76</b>
<b>4.21</b>	<b>Resume (RES)</b>	<b>76</b>
<b>4.22</b>	<b>Blocking (BLO), Blocking Acknowledgement (BLA), Continuity Check Request (CCR), Loop Back Acknowledge (LPA), Overload (OLM), Reset Circuit (RSC), Unblocking (UBL), Unblocking Acknowledgement (UBA), Unequipped CIC (UCIC)</b>	<b>77</b>
<b>4.23</b>	<b>Call Modification Completed (CMC) Call Modification Request (CMR) Call Modification Reject (CMR)</b>	<b>78</b>

<b>4.24</b>	<b>Circuit Group Blocking (CGB), Circuit Group Blocking Acknowledgement (CGBA), Circuit Group Unblocking (CGU), Circuit Group Unblocking Acknowledgement (CGUA)</b>	<b>78</b>
<b>4.25</b>	<b>Circuit Group Reset (GRS)</b>	<b>79</b>
<b>4.26</b>	<b>Circuit Group Query (CQM)</b>	<b>80</b>
<b>4.27</b>	<b>Facility Accepted (FAA) Facility Request (FAR)</b>	<b>80</b>
<b>4.28</b>	<b>Pass Along (PAM)</b>	<b>80</b>
<b>4.29</b>	<b>User part test (UPT), User part available (UPA)</b>	<b>80</b>
<b>4.30</b>	<b>Facility (FAC)</b>	<b>80</b>
<b>4.31</b>	<b>Network resource management (NRM)</b>	<b>80</b>
<b>4.32</b>	<b>Identification request (IDR)</b>	<b>80</b>
<b>4.33</b>	<b>Identification response (IDS)</b>	<b>80</b>
<b>4.34</b>	<b>Segmentation (SGM)</b>	<b>80</b>
<b>4.35</b>	<b>Loop prevention (LOP)</b>	<b>80</b>
<b>Annex A</b>	<b>Tables for handling of unrecognized parameter values</b>	<b>81</b>
<b>Annex B</b>	<b>General description of component encoding rules</b>	<b>88</b>
<b>Appendix 1</b>	<b>Circuit Identification Code (CIC) Numbering</b>	<b>89</b>
<b>Appendix 2</b>	<b>Signalling Interworking Backward Call Indicators</b>	<b>94</b>
<b>Appendix 3</b>	<b>Recommendation Q.764 Signalling Procedures</b>	<b>96</b>
<b>Appendix 4</b>	<b>Sample Message Sequences</b>	<b>100</b>
<b>Appendix 5</b>	<b>Support Of Supplementary Services</b>	<b>101</b>
	<b>Call Forwarding (CALL DIVERSION) Procedures</b>	<b>103</b>

## 0 Introduction

### 0.1 Scope

0.1.1 Part C of PTC 331 describes the functions and message formats of the ITU-T No.7 Signalling System Integrated Services Digital Network User Part (ISDN User Part or ISUP) as it applies to Telecom's Public Switched Telephone Network (PSTN) and Integrated Services Digital Network (ISDN) on the interconnect interface at a Telecom Point of Interconnect exchange (POI).

### 0.2 Relationship with ITU-T Recommendations

0.2.1 Clauses 1 to 4 of part C follow, as far as possible, the general format (paragraph, figure and table numbering) of ITU-T Recommendation Q.763 (1997) [14], to facilitate comparisons. However, some descriptions have been revised in the interests of clarity by including explanations from ITU-T Recommendations Q.762 [13] and Q.764 (1997) [15] for example, and aspects specific to Telecom's exchanges. Unless stated, such changes to wording do not imply real departures from the Q.763 recommendations. Section 2 of Q.764 is summarised in Appendix 3.

0.2.2 Some real differences do exist between Q.763 and the version of ISUP described in this part. These are typically:

- (1) Where less than the full set of ITU-T messages, parameters or facilities are available in the implementation at Telecom's POI or within Telecom's network, or where Telecom has placed a narrower interpretation on some aspects than Q.763. In these cases, except where complete messages and parameters are not implemented, the ITU-T text is reproduced here but is highlighted (as in this sentence) and explanatory text is added. In the case where complete messages and parameters are not implemented in Telecom's POI the ITU-T text is omitted from this document.
- (2) Where additional messages, parameters or facilities beyond those described by ITU-T are implemented at Telecom's POI. *In this case the text is written in bold Italics (as in this sentence).*
- (3) Comments and clarifications are written in Italics. Note that the original ITU-T text also uses Italics for emphasis.

The meaning of the different typefaces is illustrated below.

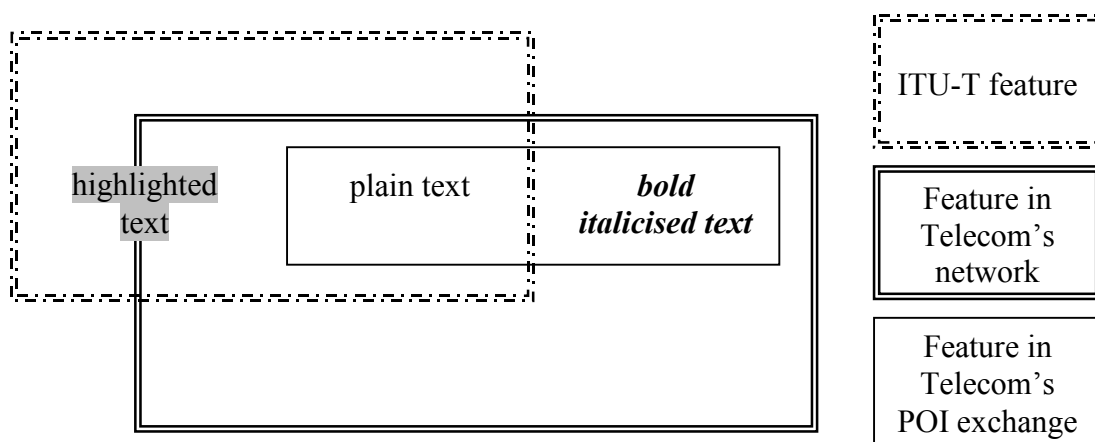

Where figures and tables have been deleted, subsequent figures and tables have not been renumbered. This maintains the numbering identical to that in ITU-T Recommendations.

### **0.3 General**

0.3.1 The ISUP is the No.7 Signalling level 4 protocol that provides the signalling functions required to support basic bearer service and supplementary services for voice and non-voice applications in the ISDN and PSTN.

0.3.2 The ISUP makes use of services provided by the No.7 Signalling Message Transfer Part (MTP) comprising levels 1 to 3. The Signalling Connection Control Part (SCCP) is not currently used by Telecom to provide services to the ISUP.

The MTP version being implemented by Telecom concurrently with this version of ISUP is based on the 1997 ITU-T Recommendations and is described in part B of this document.

0.3.3 ISUP signalling involves a series of signalling relationships between each pair of adjacent exchanges involved in a call. The ISUP messages are handled on an exchange by exchange basis, not end-to-end, except, of course, where no transit exchanges are involved in the call. End-to-end ISUP signalling using the SCCP is not used by Telecom.

0.3.4 Although the ITU-T specified MTP allows for a variety of bit rates signalling links connected to Telecom's network use only 64kbit/s.

### **0.4 Interworking with non-ISUP signalling systems**

0.4.1 The retention of Decadic Pulse (DP) and ITU-T version R2 based Multi Frequency Compelled (R2MFC) inter-exchange signalling in parts of Telecom's network will necessitate interworking between these and ISUP signalling for some calls. For some calls this may occur in the POI exchange.

0.4.2 Interworking will also take place in Telecom's network between ISUP and international signalling systems No.5, No.7 TUP and No.7 ISUP (Q.767) at Telecom's international exchanges for international calls.

0.4.3 This document primarily describes the all-ISUP environment. However interworking issues are covered in this way:

- (1) Where there is an obvious exact equivalent between ISUP and R2MFC or DP (e.g. called party number) this document makes no specific comment on interworking.
- (2) In other cases, for national calls the mapping to/from R2MFC or DP is shown in the relevant section.
- (3) Interworking to international signalling systems is in accordance with the relevant ITU-T recommendations.

### **0.5 ISUP-ISUP interworking at the Telecom POI exchange**

0.5.1 Part C of PTC331 describes the structures and meanings of ISUP messages and parameters which are currently used in the Telecom network, and which may be sent to or received from another network at the POI exchange.

0.5.2 In the event that the POI exchange receives ISUP signals from another network which do not comply with those described here, (for example values which are highlighted in this text) it will, in general, take action in accordance with ITU-T Recommendation Q.764 §2.9.5 (Receipt of unreasonable signalling information messages); i.e. the exact action will depend on the call state and the affected service. Where a general procedure applies, this is described in the text. Note, however, that the complexity of ISUP signalling means that it has not been possible to test the reaction of Telecom's network to every potential case of unreasonable and unrecognized ISUP signal received



at the POI exchange. The onus is with the interconnecting network provider to ensure that all ISUP signals sent to the Telecom POI meet the requirements of PTC331.

0.5.3 Note that in some situations the Telecom network may, on receipt from an interconnecting network of signalling information that is not used in the Telecom network and is outside the scope of Part C of PTC331, pass this information to another interconnected network, i.e., the Telecom network does not “police” the interface. Adherence to the signals defined in this specification is dependent upon the co-operation of all interconnected network operators.

## 0.6 Changes from Issue 1

The previous issue 1 (1992) of Part C to PTC331 and amendments 1, 2, 3 and 4 were based on Blue Book ITU-T Recommendations Q.763 and Q.764 (1988). This issue is based on the 1997 versions of these ITU-T Recommendations. This has resulted in major change to the layout but these do not represent technical changes to the POI exchange ISUP interface.

The only substantive technical changes from the previous issue are:

- a) Subject to agreement with the interconnected network operator new cause value 22 may be sent by Telecom to indicate release from a changed number subscriber.
- b) Subject to agreement with the interconnected network operator, forward call indicator parameter, bit M=1 can be used to indicate a reverse charge call, and bit O=1 can be used to indicate that interaction has taken place with the Intelligent Network.
- c) Subject to agreement with the interconnected network operator, flexibility in passing calling party category values between networks.

## 1 General

### 1.0 Scope, references, definitions, abbreviations

#### 1.0.1 Scope

This Recommendation specifies the formats and codes of the ISDN user part messages and parameters required to support basic bearer services and supplementary services.

#### 1.0.2 References

The following ITU-T Recommendations and other references contain provisions which, through reference in this text, constitute provisions of this Recommendation. At the time of publication, the editions indicated were valid. All Recommendations and other references are subject to revision; all users of this Recommendation are therefore encouraged to investigate the possibility of applying the most recent edition of the Recommendations and other references listed below. A list of the currently valid ITU-T Recommendations is regularly published.

- [1] ITU-T Recommendation X.208 (1988), *Specification of Abstract Syntax Notation One (ASN.1)*.
- [2] ITU-T Recommendation X.209 (1988), *Specification of basic encoding rules for Abstract Syntax Notation One (ASN.1)*.
- [3] ITU-T Recommendation X.219 (1988), *Remote operations: Model, notation, and service definition*.
- [4] ITU-T Recommendation X.229 (1988), *Remote operations: Protocol specification*.

- [5] ITU-T Recommendation G.704 (1995), *Synchronous frame structures used at 1544, 6312, 2048, 8488 and 44 736 kbit/s hierarchical levels.*
- [6] ITU-T Recommendation Q.931 (1993), *ISDN user-network interface layer 3 specification for basic call control.*
- [7] ITU-T Recommendation Q.850 (1993), *Use of cause and location in the digital subscriber Signalling System No. 1 and in the Signalling System No. 7 user part.*
- [8] ITU-T Recommendation Q.703 (1993), *Signalling link.*
- [9] ITU-T Recommendation Q.704 (1993), *Signalling System No. 7 – Signalling network functions and messages.*
- [10] ITU-T Recommendation Q.2763 (1995), *Signalling System No. 7 B-ISDN User Part (B-ISUP) – Format and codes.*
- [11] ITU-T Recommendation I.530 (03/93), *Network interworking between an ISDN and a public switched telephone network (PSTN)*
- [12] ITU-T Recommendation Q.761 (09/97), *Signalling System No. 7 – ISDN User Part Functional Description, plus Addendum 1, 05/98.*
- [13] ITU-T Recommendation Q.762 (09/97), *Signalling System No. 7 – ISDN User Part General Functions of Messages and Signals, plus Addendum 1, 05/98.*
- [14] ITU-T Recommendation Q.763 (09/97), *Signalling System No. 7 – ISDN User Part Formats and Codes, plus Addendum 1, 05/98.*
- [15] ITU-T Recommendation Q.764 (09/97), *Signalling System No. 7 – ISDN User Part Signalling Procedures, plus Addendum 1, 05/98.*
- [16] ITU-T Recommendation Q.732.2 (09/99), *Stage 3 description for call offering supplementary services using Signalling System No. 7: Call diversion services.*

### **1.0.3 Terms and definitions**

See ITU-T Recommendation Q.762.

### **1.0.4 Abbreviations**

This Recommendation uses the following abbreviations:

ASN.1	Abstract Syntax Notation One
ATP	Access Transport Parameter
BCD	Binary Coded Decimal
CCBS	Completion of Calls to Busy Subscriber
CCSS	Call Completion Service Set-up
CIC	Circuit Identification Code
CUG	Closed User Group
DNIC	Data Network Identification Code
DPC	Destination Point Code
DSS 1	Digital Subscriber Signalling System No. 1
FDM	Frequency Division Multiplex
GUG	GVNS User Group
GVNS	Global Virtual Network Service

IA5	International Alphabet No. 5
INAP	Intelligent Network Application Protocol
INN	Internal Network Number
ISC	International Switching Centre
ISDN	Integrated Services Digital Network
LFB	Look-ahead for Busy (from MLPP Supplementary Service)
LSB	Least Significant Bit
MCID	Malicious Call Identification
MLPP	Multi-Level Precedence and Preemption
MNIC	Mobile Network Identification Code
NI	Network Identity
NI	Number Incomplete
O/E	Odd/Even
OPC	Originating Point Code
OPSP	Origination Participation Service Provider
ROSE	Remote Operations Service Element
ROA	Registered Operating Agency
SCCP	Signalling Connection Control Part
SCF	Service Control Function
SLS	Signalling Link Selection
ST	End of pulsing signal (Stop Sending)
TAR	Temporary Alternative Routing
TCC	Telephony Country Code
TNRN	Termination Network Routing Number
UID	User Interactive Dialogue

For further abbreviations, see Recommendation Q.761.

### 1.0.5 General coding principles

ISDN user part messages are carried on the signalling link by means of message signal units the format of which is described in 2.2/Q.703 [8].

The format of and the codes used in the service information octet are described in 14.2/Q.704 [9]. The service indicator for the ISDN user part is coded 0101 *and the Sub Service Field is coded 1000*.

The signalling information field of each message signal unit containing an ISDN user part message consists of an integral number of octets and encompasses the following parts (see Figure 1):

- a) routing label;
- b) circuit identification code;
- c) message type code;
- d) the mandatory fixed part;
- e) the mandatory variable part;
- f) the optional part, which may contain fixed length and variable length parameter fields.

NOTE – The service information octet, the routing label and circuit identification code are not included in the SCCP user data parameter transferred between the ISDN user part and signalling connection control part. *The Signalling Connection Control Part (SCCP) is not currently used by Telecom to provide services to the ISUP.*

Routing label
Circuit identification code
Message type code
Mandatory fixed part
Mandatory variable part
Optional part

**Figure 1 – ISDN user part message parts**

A description of the various message parts is given in the following subclauses.

### 1.1 Routing label

The format and codes used for the routing label are described in 2.2/Q.704. For each individual circuit connection, the same routing label must be used for each message that is transmitted for that connection.

NOTE – The SLS bits are set to the four least significant bits of the CIC. *Telecom POI exchanges operate in accordance with the 1988 (Blue Book) recommendation and do not use this rule.*

### 1.2 Circuit identification code

The format of the Circuit Identification Code (CIC) is shown in Figure 2.

8	7	6	5	4	3	2	1
Circuit Identification Code (least significant bits)							
Spare				CIC most significant bits			

**Figure 2 – Circuit identification field**

The allocation of circuit identification codes to individual circuits is in accordance with Appendix 1 of Part C.

For international applications, the four spare bits of the circuit identification field are reserved for CIC extension, provided that bilateral agreement is obtained before any increase in size is performed. For national applications, the four spare bits can be used as required.

Allocations for certain applications are defined below:

a) *2048 kbit/s digital path*

For circuits which are derived from a 2048 kbit/s digital path (Recommendations G.732 and G.734) the circuit identification code contains in the 5 least significant bits a binary representation of the actual number of the time slot which is assigned to the communication path.

The remaining bits in the circuit identification code are used, where necessary, to identify these circuits uniquely among all other circuits of other systems interconnecting an originating and destination point.

b) 8448 kbit/s digital path

Not applicable and not reproduced.

c) Frequency Division Multiplex (FDM) systems in networks using the 2048 kbit/s pulse code modulation standard

Not applicable and not reproduced.

d) For a multirate connection type call

Not applicable and not reproduced.

e) For the N 64 kbit/s connection types

Not applicable and not reproduced.

**Table 1**

Not applicable and not reproduced

**Table 2**

Not applicable and not reproduced

**Table 3**

Not applicable and not reproduced

### 1.3 Message type code

The message type code consists of a one-octet field and is mandatory for all messages. The message type code uniquely defines the function and format of each ISDN user part message.

The allocation with reference to the appropriate descriptive tables in this Recommendation is summarized in Table 4.

**Table 4**

Message type	Abbr.	Ref. (Table)	Code
Address complete	ACM	21	0 0 0 0 0 1 1 0
Answer	ANM	22	0 0 0 0 1 0 0 1
Blocking	BLO	39	0 0 0 1 0 0 1 1
Blocking acknowledgement	BLA	39	0 0 0 1 0 1 0 1
Call progress	CPG	23	0 0 1 0 1 1 1 0
Circuit group blocking	CGB	40	0 0 0 1 1 0 0 0
Circuit group blocking acknowledgement	CGBA	40	0 0 0 1 1 0 1 0
Circuit group query (national use)	CQM	41	0 0 1 0 1 0 1 0
Circuit group query response (national use)	CQR	24	0 0 1 0 1 0 1 1
Circuit group reset	GRS	41	0 0 0 1 0 1 1 1
Circuit group reset acknowledgement	GRA	25	0 0 1 0 1 0 0 1
Circuit group unblocking	CGU	40	0 0 0 1 1 0 0 1
Circuit group unblocking acknowledgement	CGUA	40	0 0 0 1 1 0 1 1
Charge information (national use)	CRG	(Note)	0 0 1 1 0 0 0 1
Confusion	CFN	26	0 0 1 0 1 1 1 1
Connect Rx Only	CON	27	0 0 0 0 0 1 1 1
Continuity	COT	28	0 0 0 0 0 1 0 1
Continuity check request	CCR	39	0 0 0 1 0 0 0 1
Facility	FAC	45	0 0 1 1 0 0 1 1
Facility accepted	FAA	42	0 0 1 0 0 0 0 0
Facility reject	FRJ	29	0 0 1 0 0 0 0 1
Facility request	FAR	42	0 0 0 1 1 1 1 1
Forward transfer	FOT	37	0 0 0 0 1 0 0 0
Identification request	IDR	47	0 0 1 1 0 1 1 0
Identification response	IDS	48	0 0 1 1 0 1 1 1
Information (national use)	INF	30	0 0 0 0 0 1 0 0
Information request (national use)	INR	31	0 0 0 0 0 0 1 1
Initial address	IAM	32	0 0 0 0 0 0 0 1
Loop back acknowledgement (national use)	LPA	39	0 0 1 0 0 1 0 0
Loop prevention	LOP	50	0 1 0 0 0 0 0 0
Network resource management	NRM	46	0 0 1 1 0 0 1 0
Overload (national use)	OLM	39	0 0 1 1 0 0 0 0
Pass-along (national use)	PAM	43	0 0 1 0 1 0 0 0
Release	REL	33	0 0 0 0 1 1 1 0
Release complete	RLC	34	0 0 0 1 0 0 0 0
Reset circuit	RSC	39	0 0 0 1 0 0 1 0
Resume	RES	38	0 0 0 0 1 1 1 0

**Table 4**

Message type	Abbr.	Ref. (Table)	Code
Segmentation	SGM	49	0 0 1 1 1 0 0 0
Subsequent address	SAM	35	0 0 0 0 0 0 1 0
Suspend	SUS	38	0 0 0 0 1 1 0 1
Unblocking	UBL	39	0 0 0 1 0 1 0 0
Unblocking acknowledgement	UBA	39	0 0 0 1 0 1 1 0
Unequipped CIC (national use)	UCIC	39	0 0 1 0 1 1 1 0
User Part available	UPA	44	0 0 1 1 0 1 0 1
User Part test	UPT	44	0 0 1 1 0 1 0 0
User-to-user information	USR	36	0 0 1 0 1 1 0 1
Reserved (used in 1984 version)			0 0 0 0 1 0 1 0 0 0 0 0 1 0 1 1 0 0 0 0 1 1 1 1 0 0 1 0 0 0 1 0 0 0 1 0 0 0 1 1 0 0 1 0 0 1 0 1 0 0 1 0 0 1 1 0
Reserved (used in 1988 version)			0 0 0 1 1 1 0 1 0 0 0 1 1 1 0 0 0 0 0 1 1 1 1 0 0 0 1 0 0 1 1 1
Reserved (used in B-ISUP)			0 0 1 1 1 0 0 1 to 0 0 1 1 1 1 0 1
Reserved for future extension			1 0 0 0 0 0 0 0
<p>Note – The format of this message is a national matter.</p> <p><i>All messages shown are originated and received by Telecom's POI exchanges in this implementation, except:</i></p> <p><b>Highlighted messages</b> = neither originated nor received by Telecom</p> <p><i>Rx Only</i> = can be received by Telecom but not originated.</p>			

#### 1.4 Formatting principles

Each message consists of a number of PARAMETERS listed and described in clause 3. Each parameter has a NAME which is coded as a single octet (see Table 5). The length of a parameter may be fixed or variable, and a LENGTH INDICATOR of one octet for each parameter may be included as described below.

The detailed format is uniquely defined for each message type as described in clause 4.

Between parameters there should be no unused (i.e. dummy) octets.

A general format diagram is shown in Figure 3.

### **1.5 Mandatory fixed part**

Those parameters that are mandatory and of fixed length for a particular message type will be contained in the *mandatory fixed part*. The position, length and order of the parameters is uniquely defined by the message type; thus, the names of the parameters and the length indicators are not included in the message.

### **1.6 Mandatory variable part**

Mandatory parameters of variable length will be included in the *mandatory variable part*. Pointers are used to indicate the beginning of each parameter. Each pointer is encoded as a single octet. The name of each parameter and the order in which the pointers are sent is implicit in the message type. Parameter names are, therefore, not included in the message. The details of how pointers are encoded is found in 2.3. The number of parameters, and thus the number of pointers, is uniquely defined by the message type.

A pointer is also included to indicate the beginning of the optional part. If the message type indicates that no optional part is allowed, then this pointer will not be present. If the message type indicates that an optional part is possible (reflected by the presence of an "end of optional parameter" octet in Tables 21 through 50), but there is no optional part included in this particular message, then a pointer field containing all zeros will be used. It is recommended that all future message types with a mandatory variable part indicate that an optional part is allowed.

All the pointers are sent consecutively at the beginning of the mandatory variable part. Each parameter contains the parameter length indicator followed by the contents of the parameters. If there are no mandatory variable parameters, but optional parameters are possible, the start of optional parameters pointer (coded all "0"s if no optional parameter is present and coded "00000001" if any optional parameter is present) will be included.

### **1.7 Optional part**

The optional part consists of parameters that may or may not occur in any particular message type. Both fixed length and variable length parameters may be included. Unless it is explicitly stated to the contrary within this Recommendation, an optional parameter cannot occur multiple times within one message. Optional parameters may be transmitted in any order *although messages originated in Telecom exchanges normally transmit parameters in the order depicted in this document*. Each optional parameter will include the parameter name (one octet) and the length indicator (one octet) followed by the parameter contents.

### **1.8 End of optional parameters octet**

If optional parameters are present and after all optional parameters have been sent, an "end of optional parameters" octet containing all zeros will be transmitted. If no optional parameter is present (e.g. for CFN message – see Table 26), an "end of optional parameters" octet is not transmitted.

### **1.9 Order of transmission**

Since all the fields consist of an integral number of octets, the formats are presented as a stack of octets. The first octet transmitted is the one shown at the top of the stack and the last is the one at the bottom (see Figure 3).

Unless otherwise indicated, within each octet and subfield the bits are transmitted with the least significant bit first.



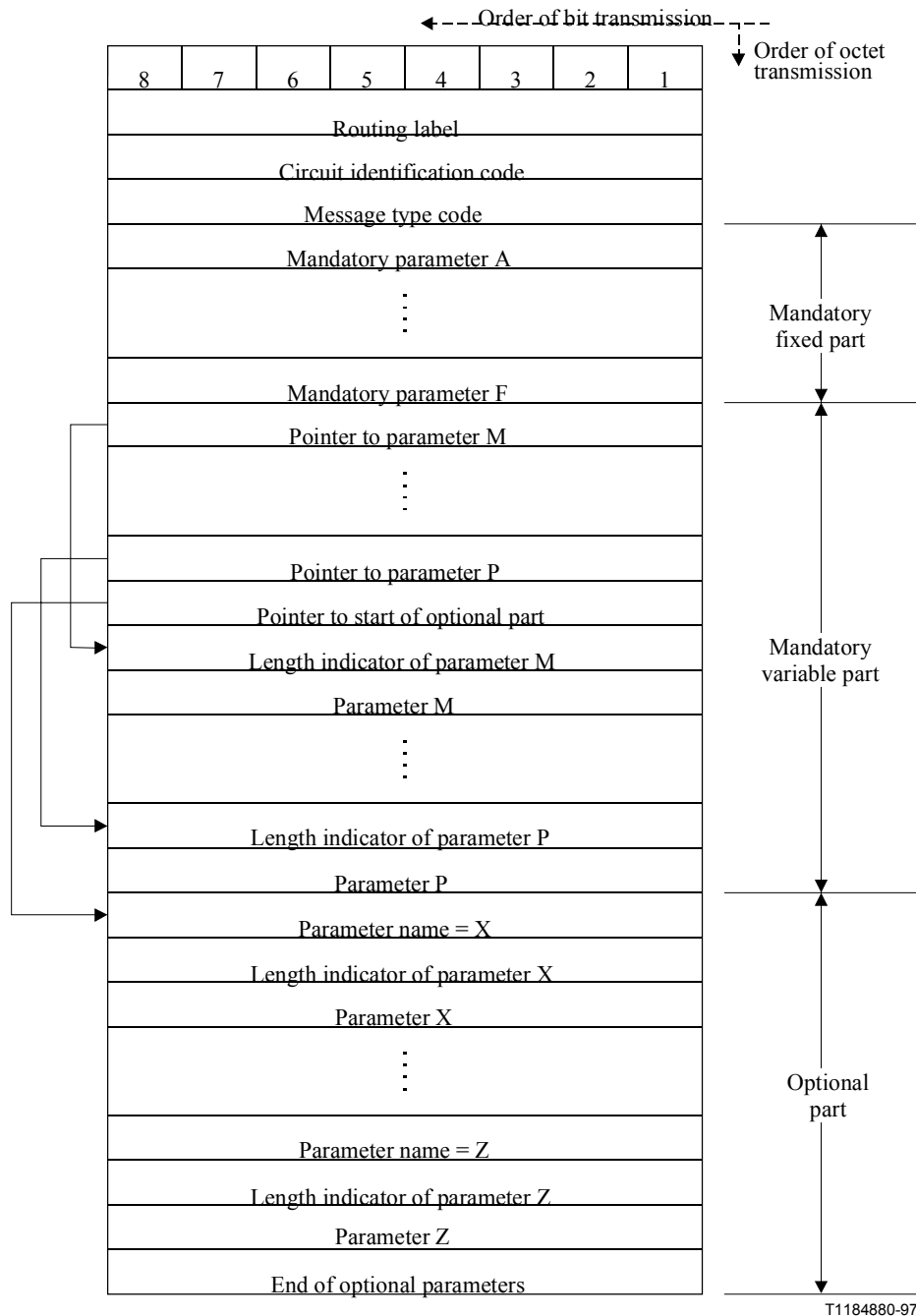

**Figure 3 – General format overview**

**1.10 Coding of spare bits**

Spare bits are coded 0 unless indicated otherwise.

**1.11 National message types and parameters**

If message type codes and parameter name codes are required for national uses not included in this Recommendation, the codes chosen should be from the highest code downwards, that is, starting at code 11111111. Message type codes in the range 11111111 to 11100000 and parameter name codes in the range 11111111 to 11000001 are reserved exclusively for national use.

*Four such parameters are used in Telecom's network. These are shown in Table 5, below, but are not sent to other networks from Telecom's POI exchange. If other network providers choose to define their own messages and parameters it is recommended that, in order to minimize potential confusion when comparing specifications and during fault handling, they avoid using the codes used in Telecom's network.*

### **1.12 Rules for the allocation of message types codes and parameter name codes**

B-ISUP message and parameter codes not used in ISUP should be marked reserved.

### **1.13 Meaning of "spare" codes and "reserved" codes**

a) Spare code: A code is indicated in this Recommendation as:

- spare;
- spare for international use; or
- spare for national use.

A code indicated as "spare" or "spare for international use" is a code available for future ITU-T use.

A code indicated as "spare for national use" is not available for ITU-T use.

b) Reserved code: A code may have been reserved in this Recommendation because of:

- a previous Recommendation;
- an intended usage (however, procedures have not been developed); or
- national use.

A code reserved for a previous Recommendation (e.g. *Blue Book*) is not available for future use.

A code reserved for an intended use (e.g. for future extension) will be specified when the intended procedures are developed.

A code reserved for national use is not available for ITU-T use.

## **2 Parameter formats and codes**

### **2.1 Message type codes**

The encoding of the message type is shown in Table 4.

### **2.2 Coding of the length indicator**

The length indicator field is binary coded to indicate the number of octets in the parameter content field. The length indicated does not include the parameter name octet or the length indicator octet.

### **2.3 Coding of the pointers**

The pointer value (in binary) gives the number of octets between the pointer itself (included) and the first octet (not included) of the parameter associated with that pointer.

The pointer value all zeros is used to indicate that, in the case of optional parameters, no optional parameter is present.

### 3 ISDN user part parameter

#### 3.1 Parameter names

The parameter name codes are given in Table 5 together with references to the subclauses in which they are described.

**Table 5**

Parameter name	Reference (subclause)	Code
Access delivery information	3.2	00101110
Access transport	3.3	00000011
Automatic congestion level	3.4	00100111
Backward call indicators	3.5	00010001
Backward GVNS	3.62	01001101
Call diversion information	3.6	00110110
Call diversion treatment indicators	3.72	01101110
Call history information	3.7	00101101
Call offering treatment indicators	3.74	01110000
Call reference (national use)	3.8	00000001
Call transfer number	3.64	01000101
Call transfer reference	3.65	01000011
Called IN number	3.73	01101111
Called party number	3.9	00000100
Calling party number	3.10	00001010
Calling party's category	3.11	00001001
Cause indicators	3.12	00010010
CCSS	3.63	01001011
Charged party identification (national use)	3.75	01110001
Circuit assignment map	3.69	00100101
Circuit group supervision message type	3.13	00010101
Circuit state indicator (national use)	3.14	00100110
Closed user group interlock code	3.15	00011010
Collect call request	3.81	01111001
Conference treatment indicators	3.76	01110010
Connected number	3.16	00100001
Connection request	3.17	00001101
Continuity indicators	3.18	00010000

**Table 5** (continued)

Parameter name	Reference (subclause)	Code
Correlation id	3.70	0 1 1 0 0 1 0 1
Display information	3.77	0 1 1 1 0 0 1 1
Echo control information	3.19	0 0 1 1 0 1 1 1
End of optional parameters	3.20	0 0 0 0 0 0 0 0
Event information	3.21	0 0 1 0 0 1 0 0
Facility indicator	3.22	0 0 0 1 1 0 0 0
Forward call indicators	3.23	0 0 0 0 0 1 1 1
Forward GVNS	3.66	0 1 0 0 1 1 0 0
Generic digits (national use)	3.24	1 1 0 0 0 0 0 1
Generic notification indicator	3.25	0 0 1 0 1 1 0 0
Generic number	3.26	1 1 0 0 0 0 0 0
Hop counter	3.80	0 0 1 1 1 1 0 1
Information indicators (national use)	3.28	0 0 0 0 1 1 1 1
Information request indicators (national use)	3.29	0 0 0 0 1 1 1 0
Location number	3.30	0 0 1 1 1 1 1 1
Loop prevention indicators	3.67	0 1 0 0 0 1 0 0
MCID request indicators	3.31	0 0 1 1 1 0 1 1
MCID response indicators	3.32	0 0 1 1 1 1 0 0
Message compatibility information	3.33	0 0 1 1 1 0 0 0
MLPP precedence	3.34	0 0 1 1 1 0 1 0
Nature of connection indicators	3.35	0 0 0 0 0 1 1 0
Network management controls	3.68	0 1 0 1 1 0 1 1
Network specific facility (national use)	3.36	0 0 1 0 1 1 1 1
Optional backward call indicators	3.37	0 0 1 0 1 0 0 1
Optional forward call indicators	3.38	0 0 0 0 1 0 0 0
Original called number	3.39	0 0 1 0 1 0 0 0
Origination ISC point code	3.40	0 0 1 0 1 0 1 1
Parameter compatibility information	3.41	0 0 1 1 1 0 0 1
Propagation delay counter	3.42	0 0 1 1 0 0 0 1
Range and status	3.43	0 0 0 1 0 1 1 0
Redirect capability (reserved for national use)	(Note)	0 1 0 0 1 1 1 0
Redirect counter (reserved for national use)	(Note)	0 1 1 1 0 1 1 1
Redirecting number	3.44	0 0 0 0 1 0 1 1
Redirection information	3.45	0 0 0 1 0 0 1 1
Redirection number	3.46	0 0 0 0 1 1 0 0
Redirection number restriction	3.47	0 1 0 0 0 0 0 0
Remote operations (national use)	3.48	0 0 1 1 0 0 1 0

**Table 5 (concluded)**

Parameter name	Reference (subclause)	Code
SCF id	3.71	0 1 1 0 0 1 1 0
Service activation	3.49	0 0 1 1 0 0 1 1
Signalling point code (national use)	3.50	0 0 0 1 1 1 1 0
Subsequent number	3.51	0 0 0 0 0 1 0 1
Suspend/Resume indicators	3.52	0 0 1 0 0 0 1 0
Transit network selection (national use)	3.53	0 0 1 0 0 0 1 1
Transmission medium requirement	3.54	0 0 0 0 0 0 1 0
Transmission medium requirement prime	3.55	0 0 1 1 1 1 1 0
Transmission medium used	3.56	0 0 1 1 0 1 0 1
UID action indicators	3.78	0 1 1 1 0 1 0 0
UID capability indicators	3.79	0 1 1 1 0 1 0 1
User service information	3.57	0 0 0 1 1 1 0 1
User service information prime	3.58	0 0 1 1 0 0 0 0
User teleservice information	3.59	0 0 1 1 0 1 0 0
User-to-user indicators	3.60	0 0 1 0 1 0 1 0
User-to-user information	3.61	0 0 1 0 0 0 0 0
Reserved (used in 1984 version, <i>Red Book</i> )		0 0 0 1 0 1 0 0 0 0 0 1 1 0 0 1 0 0 0 1 1 0 1 1 0 0 0 1 1 1 0 0 0 0 0 1 1 1 1 1
Reserved (used in 1988 version, <i>Blue Book</i> )		0 0 0 1 0 1 1 1
Reserved (used in 1992 version)		0 1 0 0 0 0 0 1 0 1 0 0 0 0 1 0
Reserved for future extension		1 0 0 0 0 0 0 0
Generic name ( <i>used within Telecom's network</i> )	-	1 1 0 0 0 1 1 1
Charge number ( <i>used within Telecom's network</i> )	-	1 1 1 0 1 0 1 1
Inter-Gateway routing ( <i>used within Telecom's network</i> )	-	1 1 1 1 1 0 1 1
Supplementary line information ( <i>used within Telecom's network</i> )	-	1 1 1 1 1 1 1 0
Note – The format of this parameter is a national matter.		
<i>All parameters shown are used in messages originated and received by Telecom's POI exchanges in this implementation, except:</i>		
<i>Highlighted parameters = not used in messages originated or received by Telecom</i>		

The following codes are reserved for use in B-ISUP:

01000110 to 01001010, 01001111 to 01011010, 01011100 to 01100100, 01100111 to 01101101.

### 3.2 Access delivery information

This section has not been reproduced as this parameter is not implemented.

### 3.3 Access transport

3.3.1 This parameter is used to carry signalling information in either direction across the No.7 signalling network between the originating and terminating ISDN subscribers connected to different exchanges. Transit exchanges in Telecom's network do not examine this parameter (other than for call charging purposes) and will pass it on, unchanged.

3.3.2 The format of the information carried in this parameter is identical to that received from the ISDN access. The parameter passes Called party subaddress, Calling party subaddress, Low layer compatibility, High layer compatibility and Progress indicator information elements from the ISDN access. In effect this parameter is used as an envelope to pass access signalling information transparently across the signalling network. Multiple information elements may be included within the Access Transport parameter. The maximum permitted length of this parameter is constrained by the maximum permitted MSU length and its other contents.

3.3.3 Access Transport is an optional parameter which may be used in the following messages:

Address Complete (ACM)	(ref. §4.2)
Answer (ANM)	(ref. §4.3)
Call Progress (CPG)	(ref. §4.4)
Connect (CON)	(ref. §4.8)
Facility (FAC)	(ref. §4.30)
Identification Response (IDS)	(ref. §4.33)
Initial Address (IAM)	(ref. §4.13)
Release (REL)	(ref. §4.14)
Segmentation (SGM)	(ref. §4.34)
User to User Information (USR)	(ref. §4.17)

However, it is not currently carried by Telecom in the ACM message, and the CON, FAC, IDS, SGM and USR messages are not currently used by Telecom, although the CON message may be received from other networks and carried in the Telecom network.

The format of the access transport parameter field is shown in Figure 5.

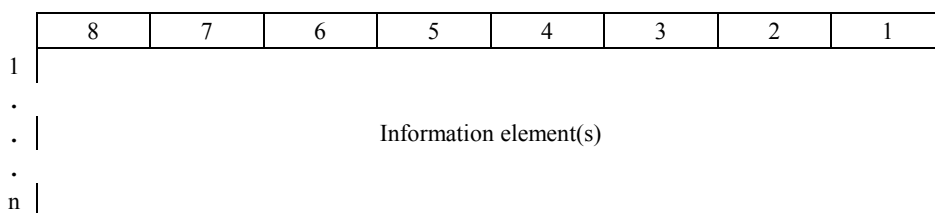

**Figure 5 – Access transport parameter field**

The information element is coded as described in 4.5/Q.931 [6]. Multiple Q.931 information elements can be included within the access transport parameter. The information elements applicable to a particular usage of the access transport parameter are dependent on, and will be determined by, the relevant procedures. The maximum length of the access transport parameter should only be limited by the message length as the content of the ATP will probably evolve in the future.

### 3.4 Automatic congestion level

3.4.1 This parameter is used to pass switching congestion level indications from a transit or terminating exchange back to the preceding exchange.

3.4.2 Receipt of this parameter by a transit or originating exchange will cause that exchange to restrict switched circuit traffic to the congested exchange (from which the message was received) in an effort to reduce the congestion there. At an ISUP-ISUP transit exchange the parameter is then discarded and not passed back to preceding exchanges.

3.4.3 Automatic Congestion Level is an optional parameter which may be used in the following message:

Release (REL) (ref. §4.14)

3.4.4 The format of the automatic congestion level parameter field is shown in Figure 6.

8	7	6	5	4	3	2	1
Automatic congestion level							

**Figure 6 – Automatic congestion level parameter field**

3.4.5 The following codes are used in the automatic congestion level parameter field:

0 0 0 0 0 0 0 0	Spare; not set by Telecom
0 0 0 0 0 0 0 1	Congestion level 1 exceeded
0 0 0 0 0 0 1 0	Congestion level 2 exceeded
0 0 0 0 0 0 1 1	Spare; not set by Telecom
to	
1 1 1 1 1 1 1 1	

3.4.6 *Telecom exchanges include Congestion Level 1 or Level 2 indication in all call release messages while occupancy of the call processor (controlling the circuit being released) exceeds criteria specified in system data. It is recommended that exchanges interconnected with the Telecom network act in accordance with ITU-T Recommendation Q.764, clause 2.11.2 during conditions of overload.*

3.4.7 *Receipt of a release message with this parameter causes Telecom exchanges to restrict traffic by application of call gapping to the overloaded exchange at a rate specified in system data. Restriction continues after receipt of the last automatic congestion control parameter for a specified retention period, then reduces to the next level of restriction and finally ceases. Calls with operator, maintenance or priority calling party's categories are not restricted. The action taken by an interconnected network upon receipt of an Automatic congestion level parameter should be in accordance with ITU-T Recommendation Q.764 §2.11.1*

### 3.5 Backward call indicators

3.5.1 This parameter is used to pass information relating to the call and the called subscriber back towards the originating exchange (i.e. in the direction from the terminating towards the originating exchange). The information may be used by the receiving exchange for charging, barring, rerouting, mapping to incoming R2MFC or mapping to originating ISDN access. *As not all values of this parameter are applicable in other networks, some particular values of Backward Call Indicators*

received from within the Telecom network will be mapped by the Telecom POI exchange to recognized Q.763 values (in accordance with the tables in Appendix 2 of this document) before they are sent to the other network.

3.5.2 Backward Call Indicators is a mandatory fixed length parameter in the following messages:

Address Complete (ACM) (ref. §4.2)

Connect (CON)\* (ref. §4.8)

\* However, the Connect message is not originated by Telecom.

It is also an optional parameter which may be included in the following messages:

Answer Message (ANM) (ref. §4.3)

Call Progress Message (CPG) (ref. §4.4)

However, it is not used in these messages by Telecom.

The format of the backward call indicators parameter field is shown in Figure 7.

	8	7	6	5	4	3	2	1
1	H	G	F	E	D	C	B	A
2	P	O	N	M	L	K	J	I

**Figure 7 – Backward call indicators parameter field**

The following codes are used in the backward call indicators parameter field:

bits

BA Charge indicator (Note 1)

0 0 no indication; set when the call is intercepted by an announcement, operator or IN node, or switched to an outgoing DP route, or when an outgoing R2MFC route receives an A-6 signal

0 1 no charge; not set by Telecom; passed transparently if received from another network at a POI or from the international network

1 0 charge; set when the call terminates, or when an outgoing R2MFC route receives B-1, B-6, B-7, B-9 or B-10

1 1 spare; not set by Telecom; passed transparently if received from another network at a POI

NOTE 1 – The interpretation of these bits depends only on the charging exchange.

NOTE 1a – Although carried, Telecom does not base its charging on the value of these bits.



bits

DC

Called party's status indicator

0 0

no indication; *set when the call terminates to an ISDN or DDI line, is intercepted by an announcement, operator or IN node, or switched to an outgoing DP route, or when an outgoing R2MFC route receives A-6 signal*

0 1

subscriber free; *set when call terminates to a free non-DDI PSTN line, or when outgoing R2MFC route receives B-1, B-6, B-7, B-9 or B-10; may also be received from other networks for calls terminating on some ISDN terminals (ref. ITU-T Q.699 Fig. 5)*

1 0

connect when free (national use); *not set by Telecom. Passed transparently if received from another network at a Telecom POI exchange*

1 1

Spare; *not set by Telecom. Passed transparently if received from another network at a Telecom POI exchange*

bits

FE

Called party's category indicator

0 0

no indication; *set when the call is intercepted by an announcement, operator or IN node, or switched to an outgoing DP route, or when an outgoing R2MFC route receives A-6 signal*

0 1

ordinary subscriber; *set when call terminates to a line which is neither barred incoming collect nor INWATS terminating category, or when call is switched to an outgoing R2MFC route which receives B-1 or B-6*

1 0

payphone; *used in the Telecom network. Not sent from a Telecom POI to another network.*

1 1

Spare; *not set by Telecom*

bits

HG

End-to-end method indicator (Note 2)

0 0

no end-to-end method available (only link-by-link method available) ; *set for all calls*

0 1

pass-along method available (national use); *not set by Telecom; mapped to value 00 if received from another network at a POI*

1 0

SCCP method available; *not set by Telecom; mapped to value 00 if received from another network at a POI*

1 0

pass-along and SCCP methods available (national use) ; *not set by Telecom; mapped to value 00 if received from another network at a POI*

bit

I

Interworking indicator (Note 2)

0

no interworking encountered (Signalling System No. 7 all the way); *set when No.7 is used all the way back from the terminating exchange*

1

interworking encountered; *set in messages returned from transit exchanges where outgoing signalling is not No.7, or when the call is intercepted by an announcement, operator or IN node*

bit

J

End-to-end information indicator (Note 2) (national use)

0

no end-to-end information available; *set for all calls*

1

end-to-end information available, *i.e., awaiting transmission; not set by Telecom; mapped to value 0 if received from another network at a POI*

bit  
K ISDN user part indicator (Note 2)  
0 ISDN user part not used all the way; *set in messages returned from transit exchanges where outgoing signalling is not ISUP, or when the call is intercepted by an announcement, operator or IN node*  
1 ISDN user part used all the way

bit  
L Holding indicator (national use)  
0 holding not requested; *set for all calls*  
1 holding requested; *not set by Telecom; mapped to value 0 if received from another network at a POI*

bit  
M ISDN access indicator  
0 terminating access non-ISDN or not known; *also used when the call is intercepted by an announcement, operator or IN node*  
1 terminating access ISDN and ISUP used all the way

bit  
N Echo control device indicator  
0 incoming echo control device not included; *set for all calls*  
1 incoming echo control device included; *not set by Telecom; passed transparently if received from another network at a POI*

bits  
PO SCCP method indicator (Note 2)  
0 0 no indication; *set for all calls*  
0 1 connectionless method available (national use); *not set by Telecom; mapped to value 00 if received from another network at a POI*  
1 0 connection oriented method available; *not set by Telecom; mapped to value 00 if received from another network at a POI*  
1 1 connectionless and connection oriented methods available (national use) ; *not set by Telecom; mapped to value 00 if received from another network at a POI*

NOTE 2 – Bits G-K and O-P constitute the protocol control indicator.

NOTE 3 – For calls terminating in Telecom's network bits I and K convey identical information because ISUP is the only part of No.7 signalling used for call control. (When I=0, K=1).

NOTE 4 – The contents of bits I, K and M can be mapped to the originating ISDN access.

NOTE 5 – Bit I=1 and bit K=0 are returned from an exchange where a call is intercepted by an operator, an announcement or by the Intelligent Network for input of in-band tones, even though ISUP is used all the way.

### 3.6 Call diversion information

This section has not been reproduced as this parameter is not implemented.

### 3.7 Call history information

This section has not been reproduced as this parameter is not implemented.

### 3.8 Call reference (national use)

This section has not been reproduced as this parameter is not implemented.

### 3.9 Called party number

3.9.1 This parameter is used to send the called number forward to each succeeding exchange in the call set-up sequence for use in call routing. When this parameter is sent from a Telecom POI it always includes all required digits of the called party number, as the ISUP signalling used is en-bloc, not overlap.

3.9.2 Called Party Number is mandatory variable length parameter used in the following message:

Initial Address (IAM) (ref. §4.13)

The format of the called party number parameter field is shown in Figure 10.

	8	7	6	5	4	3	2	1
1	Odd/ even	Nature of address indicator						
2	INN Ind.	Numbering plan Ind.			Spare			
3	2nd address signal				1st address signal			
.								
.								
n	Filler (if necessary)				nth address signal			

**Figure 10 – Called party number parameter field**

The following codes are used in the subfields of the called party number parameter field:

a) *Odd/even indicator*

- |   |   |
|---|---|
| 0 | even number of address signals ( <i>last octet has no filler</i> )                        |
| 1 | odd number of address signals ( <i>last octet has one address signal and one filler</i> ) |

b) *Nature of address indicator*

0 0 0 0 0 0 0	spare; <i>not set by Telecom</i>
0 0 0 0 0 0 1	subscriber number (national use) ; <i>not set by Telecom</i>
0 0 0 0 0 1 0	Unknown (national use); <i>used for all calls (Note 1)</i>
0 0 0 0 0 1 1	national (significant) number; <i>not set by Telecom</i>
0 0 0 0 1 0 0	international number; <i>not set by Telecom</i>
0 0 0 0 1 0 1	network-specific number (national use); <i>not set by Telecom</i>
0 0 0 0 1 1 0	spare; <i>not set by Telecom</i>
to	
1 1 0 1 1 1 1	reserved for national use; <i>not set by Telecom</i>
1 1 1 0 0 0 0	
to	
1 1 1 1 1 1 0	spare; <i>not set by Telecom</i>
1 1 1 1 1 1 1	

*NOTE 1 - Indicates that the format of the called party number forwarded in the address signal subfields will be by agreement between the network operators, in accordance with Part A section 11.5.*

*NOTE 2 - All values of Nature of Address indicator received from another network at a POI are mapped to 0000010*

c) *Internal Network Number indicator (INN ind.)*

0	routing to internal network number allowed; <i>set for all calls</i>
1	routing to internal network number not allowed; <i>not set by Telecom; mapped to value 0 if received from another network at a POI</i>

d) *Numbering plan indicator*

0 0 0	spare; <i>not set by Telecom</i>
0 0 1	ISDN (Telephony) numbering plan (Recommendation E.164); <i>set for all calls</i>
0 1 0	spare; <i>not set by Telecom</i>
0 1 1	Data numbering plan (Recommendation X.121) (national use); <i>not set by Telecom</i>
1 0 0	Telex numbering plan (Recommendation F.69) (national use); <i>not set by Telecom</i>
1 0 1	reserved for national use; <i>not set by Telecom</i>
1 1 0	reserved for national use; <i>not set by Telecom</i>
1 1 1	spare; <i>not set by Telecom</i>

*NOTE – All values of Numbering plan indicator received from another network at a POI are mapped to 001.*

e) *Address signal*

0 0 0 0	digit 0	
0 0 0 1	digit 1	
0 0 1 0	digit 2	
0 0 1 1	digit 3	
0 1 0 0	digit 4	
0 1 0 1	digit 5	
0 1 1 0	digit 6	
0 1 1 1	digit 7	
1 0 0 0	digit 8	
1 0 0 1	digit 9	
1 0 1 0	spare	<i>not set by Telecom; if received from another network, these values will cause the call to be released</i>
1 0 1 1	code 11	
1 1 0 0	code 12	
1 1 0 1	spare	
1 1 1 0	spare	
1 1 1 1	ST; always included after the last digit of called party number used in the Telecom network, to indicate that no subsequent address messages follow the IAM	

The most significant address signal is sent first. Subsequent address signals are sent in successive 4-bit fields.

*Telecom's network can support up to 24 digits plus the ST signal in this field. The actual length used will depend on the numbering plan.*

f) *Filler*

In case of an odd number of address signals, the filler code 0000 is inserted after the last address signal.

### 3.10 Calling party number

3.10.1 This parameter is used to send forward the calling party number for use in charging, malicious call trace printout, display to operators and delivery to customers subscribing to Calling Line Identity Presentation (CLIP) service. *Refer to Part A section 11.6 (3) concerning the intended use of this parameter.*

3.10.2 Calling Party Number is an optional parameter which may be used in the following messages:

Identification Response (IDS)	(ref. §4.33)
Information (INF)	(ref. §4.11)
Initial Address (IAM)	(ref. §4.13)

However, it is not used in the IDS and INF messages by Telecom.

3.10.3 *The method of sending calling party number from a Telecom POI exchange to an interconnected network depends on which of the following options is selected by the other network operator to apply to the interconnect route:*

*OPTION A The Telecom POI will always include the full calling party number in the IAM for all calls, where it is available*

*OPTION B The Telecom POI will always include the first 4 digits of the Calling Party Number in the IAM. In this case, the Calling Party Number Incomplete indicator is set to incomplete and the Address Presentation Indicator is set to Restricted.*

*OPTION C The Telecom POI will not send a Calling Party Number parameter for any calls.*

*Refer to Appendix 4 (Figs. 1a to 1f) for associated message handling.*

3.10.4 *The User-provided, verified and passed calling party number is sufficient for charging purposes and the INR/INF procedure is no longer to be used within the Telecom network. All references to INR and INF have been highlighted in this specification to indicate “not supported by Telecom”.*

The format of the calling party number parameter field is shown in Figure 11.

	8	7	6	5	4	3	2	1
1	Odd/ even	Nature of address indicator						
2	NI	Numbering plan Ind.			Address presentation restricted indicator		Screening	
3	2nd address signal				1st address signal			
.								
.								
n	Filler (if necessary)				nth address signal			

**Figure 11 – Calling party number parameter field**

The following codes are used in the calling party number parameter field.

a) *Odd/even indicator*

See 3.9.2 a)

b) *Nature of address indicator*

0 0 0 0 0 0	spare; <i>not set by Telecom</i>
0 0 0 0 0 1	subscriber number (national use) ; <i>not set by Telecom</i>
0 0 0 0 1 0	unknown (national use) ; <i>not set by Telecom</i>
0 0 0 0 1 1	national (significant) number (national use) ( <i>normally in the format Toll Group Code + Directory Number</i> ); <i>set for all national network originated calls where available</i>
0 0 0 0 1 0 0	international number; <i>set for incoming international calls that use ISUP all the way from the international exchange</i>
0 0 0 0 1 0 1	
to	spare; <i>not set by Telecom</i>
1 1 0 1 1 1 1	
1 1 1 0 0 0 0	
to	reserved for national use; <i>not set by Telecom</i>
1 1 1 1 1 1 0	
1 1 1 1 1 1 1	spare; <i>not set by Telecom</i>

c) *Number Incomplete indicator (NI)*

0 complete

1 incomplete; *set when a partial calling party number is provided in the following cases:*

- *for calls originated from M party lines;*
- *beyond R2MFC-ISUP interworking point when ONI calling party category is received;*
- *beyond DP-ISUP interworking point when calling party number is generated at the interworking exchange; and*
- *when calling party number is coded '0000' for incoming international calls (when true calling party number is unavailable)*

d) *Numbering plan indicator*

See 3.9.2 d)

e) *Address presentation restricted indicator*

0 0 presentation allowed (*to a terminating customer subscribing to CLIP supplementary service*); *set except in cases below, and always set beyond MFC or DP interworking point*

0 1 presentation restricted (*available to operators and services with special status only*); *set where originating customer subscribes to CLIR supplementary service, or where originating customer has a special billing number*

1 0 address not available (Note) (national use); *not set by Telecom; passed transparently if received*

1 1 spare; *not set by Telecom*

NOTE – If the parameter is included and the address presentation restricted indicator indicates address not available, octets 3 to n are omitted, the subfields in items a), b), c) and d) are coded with 0's, and the subfield f) is coded with 11.

*NOTE 2 – Also refer to Part A, para 11.6.*

f) *Screening indicator*

0 0	reserved (Note); <i>not set by Telecom</i>
0 1	user provided, verified and passed; <i>set to indicate that calling party number is a valid number supplied by the originating ISDN subscriber in setup message</i>
1 0	reserved (Note); <i>not set by Telecom</i>
1 1	network provided; <i>set in all other cases to indicate that calling party number is that registered to the originating subscriber line, or for an ONI subscriber, the number entered by the operator</i>

NOTE – Code 00 and 10 are reserved for "user provided, not verified" and "user provided, verified and failed" respectively. Codes 00 and 10 are for national use.

g) *Address signal*

0 0 0 0	digit 0
0 0 0 1	digit 1
0 0 1 0	digit 2
0 0 1 1	digit 3
0 1 0 0	digit 4
0 1 0 1	digit 5
0 1 1 0	digit 6
0 1 1 1	digit 7
1 0 0 0	digit 8
1 0 0 1	digit 9
1 0 1 0	spare; <i>not set by Telecom</i>
1 0 1 1	code 11 ) <i>not set by Telecom but may be received from another</i>
1 1 0 0	code 12 ) <i>network</i>
1 1 0 1	
to	spare; <i>not set by Telecom</i>
1 1 1 1	

*Telecom's network can support up to 24 digits in this field. Interconnecting networks must support at least 15 digits as specified in ITU-T Recommendation E.164.*

h) *Filler*

See 3.9 f).

### 3.11 Calling party's category

3.11.1 This parameter is used to send the calling party's category to each succeeding exchange in the call set-up sequence. It is used for charging, routing and barring purposes. In general at a transit exchange the Calling Party Category may change or remain the same, depending on the call type. *At a Telecom POI exchange, because not all values of this parameter are applicable in other networks, some values are mapped to applicable values in agreement with the interconnected network operator.*

3.11.2 *Calling Party's Category is a mandatory fixed length parameter used in the following message.*

*Initial Address (IAM) (ref. §4.13)*

*It is also an optional parameter which may be used in the following message:*

*Information (INF)*

*(ref. §4.11)*

*However, it is not used in this message by Telecom.*

The format of the calling party's category parameter field is shown in Figure 12.

8	7	6	5	4	3	2	1
Calling party's category							

**Figure 12 – Calling party's category parameter field**

The following codes, with meanings, equivalent R2MFC signals, and mappings to and from other networks at the Telecom POI exchange shown, are used in the calling party's category parameter field.



Code	Description	R2MFC Equiv.	Used in Telecom Network	If received at Telecom POI exchange	
				Value mapped to other network <sup>1</sup>	Value mapped to Telecom network <sup>2</sup>
0000 0000	calling party's category unknown at this time (national use)	-	NO	N.A.	0000 1010
0000 0001	operator, language French	-	NO	N.A.	Invalid
0000 0010	operator, language English	-	NO	N.A.	Invalid
0000 0011	operator, language German	-	NO	N.A.	Invalid
0000 0100	operator, language Russian	-	NO	N.A.	Invalid
0000 0101	operator, language Spanish	-	NO	N.A.	Invalid
0000 0110 0000 0111 0000 1000	(available to Administrations for selection a particular language by mutual agreement)	-	NO	N.A.	Invalid
0000 1001	reserved (see Recommendation Q.104) (Note 1) (national use) <i>Operator</i>	GII-5	YES	Note 2	Note 2
0000 1010	ordinary calling subscriber	GII-1	YES	Note 2	Note 2
0000 1011	calling subscriber with priority	GII-2	YES	Note 2	Note 2
0000 1100	data call (voice band data)	GII-10	YES	Note 2	Note 2
0000 1101	test call	GII-3	YES	Note 2	Note 2
0000 1110	spare	-	NO	N.A.	Invalid
0000 1111	payphone	GII-6	YES	Note 2	Note 2
0001 0000 to 1101 1111	spare	-	NO	N.A.	Invalid
1110 0000 to 1111 0110	reserved for national use	-	NO	N.A.	Invalid
1111 0111	<i>Used for Telecom network services</i>	<i>GII-15</i>	<i>YES</i>	<i>0000 1010</i>	<i>0000 1010</i>
1111 1000		<i>GII-14</i>	<i>YES</i>	<i>0000 1010</i>	<i>0000 1010</i>
1111 1001		<i>GII-13</i>	<i>YES</i>	<i>0000 1010</i>	<i>0000 1010</i>
1111 1010	<i>Operator Number Identification</i>	<i>GII-12</i>	<i>YES</i>	Note 2	Note 2
1111 1011	<i>Used for Telecom network services</i>	<i>GII-11</i>	<i>YES</i>	<i>0000 1010</i>	<i>0000 1010</i>
1111 1100	reserved for national use	-	NO	N.A.	Invalid
1111 1101	<i>Used for Telecom network services</i>	<i>GII-5</i>	<i>YES</i>	<i>0000 1010</i>	<i>0000 1010</i>
1111 1110		<i>GII-4</i>	<i>YES</i>	<i>0000 1010</i>	<i>0000 1010</i>
1111 1111	spare	-	NO	N.A.	Invalid

Note 1 – In national networks, code 00001001 may be used to indicate that the calling party is a national operator.

Note 2 – subject to agreement with the interconnect network operator these values may be either passed transparently or mapped to 0000 1010.

<sup>1</sup> – N.A. = Not Applicable

<sup>2</sup> – Invalid values received at a POI will cause the call to be released with cause value 21

### 3.12 Cause indicators

3.12.1 This parameter is used to convey information in either the forward or backward direction concerning the reason why a call has failed to mature or has been released.

When the Cause Indicator included in a REL message sent in the forward direction (i.e. towards the terminating exchange) is received:

- (1) an ISUP-ISUP transit exchange will pass the parameter on unchanged if it is a recognised value, otherwise it will be changed to the “unspecified” value for the class.
- (2) an ISUP-R2MFC or DP transit exchange will convert the cause indicator to a clear forward line signal
- (3) a terminating exchange will, if the terminating customer is still connected, pass the information in the cause indicator on to the terminating customer via the access signalling or as an inband tone.

When the Cause Indicator included in a REL message sent in the backward direction (i.e. towards the originating exchange) is received:

- (1) an ISUP-ISUP transit exchange will pass the parameter on, unchanged
- (2) an ISUP-R2MFC transit exchange will convert the cause indicator into the relevant backward MFC message
- (3) an originating exchange will, if the originating customer is still connected, pass the information in the cause indicator on to the originating customer via the access signalling or as an inband tone, or action any instruction contained in the received cause value.

3.12.2 Cause Indicators is a mandatory variable length parameter in the following messages:

Confusion (CFN)	(ref. §4.7)
Facility Reject (FRJ)	(ref. §4.10)
Release (REL)	(ref. §4.14)

However, the Facility Reject message is not currently used by Telecom.

It is also an optional parameter which may be used in the following messages:

Address Complete (ACM)	(ref. §4.2)
Call Progress (CPG)	(ref. §4.4)
Release Complete (RLC)	(ref. §4.15)

However, it is not generated in the ACM, CPG and RLC messages within the Telecom network but may be passed if received by another network.

The format of the cause indicators parameter field is shown in Figure 13.

	8	7	6	5	4	3	2	1
1	ext.	Coding standard		Spare	Location			
2	ext.	Cause value						
3	Diagnostic(s) (if any)							
.								
.								
n								

NOTE – Octet 3 to 3n may be omitted or repeated, e.g. 3' to 3'n.

**Figure 13 – Cause indicators parameter field**

The codes to be used in the subfields of the cause indicators parameter fields are defined in Recommendation Q.850 [7] and is summarised below. Section number from Recommendation Q.850 is retained to allow easy reference.

#### Q.850/2.2.1 Extension indicator (ext.)

Bit

8

0 octet continues through the next octet (e.g. octet 1 to 1a)

1 last octet

#### Q.850/2.2.2 Coding standard

Bits

7 6

0 0 ITU-T standardized coding, as described below; *set for all calls*

0 1 ISO/IEC standard (see Note) ; *not set by Telecom*

1 0 national standard (see Note) ; *not set by Telecom*

1 1 standard specific to identified location (see Note) ; *not set by Telecom*

NOTE – These other coding standards should be used only when the desired cause value cannot be represented with the ITU-T-standardized coding.

#### Q.850/2.2.3 Location

Bits

4 3 2 1

0 0 0 0 user (U); *set when cause is received from the ISDN Access*

0 0 0 1 private network serving the local user (LPN) ; *not set by Telecom*

0 0 1 0 public network serving the local user (LN); *set when cause is initiated at a Telecom exchange served by No. 7 signalling*

0 0 1 1 transit network (TN) ; *to be sent to Telecom's POI when cause is initiated at a bypass network operator's exchange. Not generated in the Telecom network; carried if received from another network*

0 1 0 0 public network serving the remote user (RLN) ; *not set by Telecom*

0 1 0 1 private network serving the remote user (RPN) ; *generated on receipt of LPN from a private network*

- 0 1 1 1 international network (INTL); *set when cause is initiated in the international network*
  - 1 0 1 0 network beyond interworking point (BI) ; *set when the cause value is based on information received from another signalling system e.g. R2MFC*
  - 1 1 0 0 reserved for national use; *not set by Telecom*
  - 1 1 0 1 reserved for national use; *not set by Telecom*
  - 1 1 1 0 reserved for national use; *not set by Telecom*
  - 1 1 1 1 reserved for national use; *not set by Telecom*
- All other values are spare; *not set by Telecom*

#### **Q.850/2.2.4 Recommendation**

Bits

7 6 5 4 3 2 1

0 0 0 0 0 0 0 Q.763/Q.931; *set for all calls*

0 0 0 0 0 1 1 X.21; *not set by Telecom*

0 0 0 0 1 0 0 X.25; *not set by Telecom*

0 0 0 0 1 0 1 public land mobile networks, Q.1031/Q.1051 ; *not set by Telecom*

All other values are reserved ; *not set by Telecom*

NOTE – If octet including this field is omitted, Recommendation Q.763/Q.931 is assumed.

#### **Q.850/2.2.5 Cause value (only applicable in the context of Recommendations Q.763 and Q.931)**

The cause value is divided into two fields, a class (bits 5 through 7) and a value within the class (bits 1 through 4).

- 1) The class indicates the general nature of the event.
  - Class (000): normal event
  - Class (001): normal event
  - Class (010): resource unavailable
  - Class (011): service or option not available
  - Class (100): service or option not implemented
  - Class (101): invalid message (e.g. parameter out of range)
  - Class (110): protocol error (e.g. unknown message)
  - Class (111): interworking
- 2) The cause values are listed in Table 1.

#### **Q.850/2.2.6 Diagnostics (only applicable in the context of Recommendations Q.763 and Q.931)**

The diagnostics applicable to each cause value are given in Table 1. Diagnostic information is not available for every cause. In those cases in which the diagnostic is a Q.931 information element, the coding of the diagnostic is the same as for the corresponding information element in 4/Q.931.

**Q.850/2.2.6.1 Coding of Condition**

The condition diagnostic is coded as follows:

- Bit 8: 1
- Bits 7-5: 000
- Bit 4: Condition as follows:  
0 – Network service – Provider  
1 – Network service – User
- Bit 3: Condition as follows:  
0 – Normal  
1 – Abnormal
- Bits 2-1: Condition as follows:  
00 – Unknown  
01 – Permanent  
10 – Transient

**Q.850/2.2.6.2 Coding of Transit network identity**

The diagnostic field contains the entire transit network selection or network specific facilities information element as applicable, including parameter name/information element identifier and length octet.

**Q.850/2.2.6.3 Coding of CCBS indicator**

The CCBS indicator is coded as follows:

- Bits 8-1: 00000000 – Spare  
00000001 – CCBS possible  
00000010 – CCBS not possible  
00000011  
to – Spare  
01111111  
10000000  
to – Spare for national use  
11111110  
11111111 – Reserved for extension

NOTE – Not used in Recommendation Q.931.

TABLE 1/Q.850

**Cause information element/parameter**

Cause Class	Definition		Diagnostics	Tone	R2MFC	Application (Note 1)	Reference (Note 2)	Remarks
	Value	No.						
000	0001	1	Unallocated (unassigned) number	Condition	NUT	B-5	ISUP	Q.931
000	0010	2	No route to specified transit network	Transit network identify	DSCT	B-4	ISUP(NU)	Q.931
000	0011	3	No route to destination	Condition	NUT	B-5	ISUP	Q.931
000	0100	4	Send special information tone		DSCT	B-4	ISUP	Clause 7/Q.35. Not set by Telecom
000	0101	5	Misdialed trunk prefix		DSCT	B-4	ISUP(NU)	Not set by Telecom
000	0110	6	Channel unacceptable				DSS 1	Q.931
000	0111	7	Call awarded and being delivered in an established channel				DSS 1	Q.931
000	1000	8	Preemption		DSCT	B-4	ISUP	Q.735.3
000	1001	9	Preemption – circuit reserved for reuse		DSCT	B-4	ISUP	Q.735.3
001	0000	16	Normal call clearing	Condition	DSCT	cfd/clb	ISUP	2.3/Q.764
001	0001	17	User busy	CCBS Indicator	BT	B-3	ISUP	Q.732, Q.733.3
001	0010	18	No user responding		DSCT	cfd	ISUP	Q.732
001	0011	19	No answer from user (user alerted)		DSCT	cfd	ISUP	Q.931
								2.1.4/Q.764
								2.9.8.3/Q.764
								Q.732
								Call diversion services

Cause		Definition		Diagnostics	Tone	R2MFC	Application (Note 1)	Reference (Note 2)	Remarks
Class	Value	No.							
001	0100	20	Subscriber absent		DSCT	B-4	ISUP		Mobile application. Not set by Telecom
001	0101	21	Call rejected	Call rejected condition	DSCT	B-4	ISUP	Q.732	Call diversion services
001	0110	22	Number changed. Used by arrangement only. <i>Used to reroute speech and 3.1kHz audio calls to an operator. On a call from another network, the POI will, for speech &amp; 3.1kHz audio calls on agreement with the interconnected network operator, either interconnect the call to a Telecom operator or pass transparently; for 64kbit/s calls pass transparently.</i>	New destination (DSS 1)/ called party number (ISUP)	(NUT)	B-2	ISUP	Q.931	
001	0111	23	Redirection to new destination				ISUP		Not set by Telecom
001	1001	25	Exchange routing error				ISUP		Not set by Telecom
001	1010	26	Non-selected user clearing				DSS 1	Q.931	DSS1 only
001	1011	27	Destination out of order		(NUT)	B-8	ISUP	Q.931	
001	1100	28	Invalid number format (address incomplete)		DSCT	B-4	ISUP	Q.931	
								2.1.1/Q.764 2.1.2/Q.764 2.9.8.3/Q.764 2.2.5/Q.764	The called party number is not in a valid format or is not complete
								Annex A/Q.763	
001	1101	29	Facility rejected	Facility Identification (DSS 1)/ parameter name (SUP)	DSCT	B-4	ISUP	Q.931	Not set by Telecom
									Inability to provide a request signalling capability
								Q.735.1	CUG
								Q.737.1	UUS
001	1110	30	Response to STATUS ENQUIRY				DSS 1	Q.931	DSS1 only

Cause		Definition	Diagnostics	Tone	R2MFC	Application (Note 1)	Reference (Note 2)	Remarks
Class	Value No.							
001	1111 31	Normal, unspecified		DSCT	cfb/clb	ISUP	2.1.1/Q.764 2.1.2/Q.764 2.8.1/Q.764 2.8.2/Q.764 2.9.3/Q.764 2.9.6/Q.764 2.9.8.2/Q.764 2.9.8.3/Q.764 2.1.8/Q.764 2.2.4/Q.764	Call failure information indicating the failure of a call due to the lapse of a timeout or a fault not covered by specific causes (examples: expiry of timers Q.764 not covered by specific causes, release of interconnected circuit, etc.)
010	0010 34	No circuit/channel available	CCBS Indicator	DSCT	A-4	ISUP	2.1.6/Q.764 2.9.7/Q.764 Annex A/Q.763 Q.931, Q.733.3	Expiry of waiting INF timer (T33) Circuit congestion encountered in an exchange. Not set by Telecom
010	0110 38	Network out of order		DSCT	B-4	ISUP	Q.931	Not set by Telecom
010	0111 39	Permanent frame mode connection out of service				DSS 1	Q.933	DSS1 only
010	1000 40	Permanent frame mode connection operational				DSS 1	Q.933	DSS1 only
010	1001 41	Temporary failure		DSCT	B-4	ISUP	Q.931	
010	1010 42	Switching equipment congestion		DSCT	B-4	ISUP	2.9.9.1/Q.764	Temporary trunk block (national use)
010	1011 43	Access information discarded	Discarded information element identifier(s) (Note 4)	DSCT	B-4	ISUP	Q.931	Not set by Telecom
010	1100 44	Requested circuit/channel not available		DSCT	B-4	DSS 1, ISUP	Q.931	Not set by Telecom



Cause Class	Cause		Definition	Diagnostics	Tone	R2MFC	Application (Note 1)	Reference (Note 2)	Remarks
	Value	No.							
010	1110	46	Precedence call blocked		DSCT	B-4	DSS 1, ISUP	Q.735.3	MLPP. Not set by Telecom
010	1111	47	Resource unavailable, unspecified		DSCT	A-4	DSS 1, ISUP	Q.931 Annex A/Q.763	
011	0001	49	Quality of service unavailable	Condition			DSS 1	Q.931	DSS1 only
011	0010	50	Requested facility not subscribed	Facility Identification (DSS 1)/parameter name (ISUP)	NUT	B-4	DSS 1, ISUP	Q.931, Q.735	Not set by Telecom
011	0101	53	Outgoing calls barred within CUG		DSCT	B-4	ISUP	Q.735.1	CUG. Not set by Telecom
011	0111	55	Incoming calls barred within CUG		NUT	B-5	ISUP	Q.735.1	CUG
011	1001	57	Bearer capability not authorized	Attribute identity	NUT	B-5	DSS 1, ISUP	Q.931	
011	1010	58	Bearer capability not presently available	Attribute identity	NUT	B-5	DSS 1, ISUP	Q.931	
011	1110	62	Inconsistency in designated outgoing access information and subscriber class		DSCT	B-4	DSS 1, ISUP	Q.735	Not set by Telecom
011	1111	63	Service or option not available, unspecified		NUT	B-5	DSS 1, ISUP	Annex A/Q.763	
100	0001	65	Bearer capability not implemented	Attribute identity	NUT	B-5	DSS 1, ISUP	Annex A/Q.763	Inability to provide a requested TMR
100	0010	66	Channel type not implemented	Channel type			DSS 1	Q.931	DSS1 only
100	0101	69	Requested facility not implemented	Facility Identification (DSS 1)/parameter name (ISUP)	DSCT	B-4	DSS 1, ISUP	Q.931, Q.737.1	UUS. Not set by Telecom
100	0110	70	Only restricted digital information bearer capability is available		DSCT	B-4	DSS 1, ISUP (NU)	Q.931	Not set by Telecom
100	1111	79	Service or option not implemented, unspecified		NUT	B-5	DSS 1, ISUP	Annex A/Q.763	
101	0001	81	Invalid call reference value				DSS 1	Q.931	DSS1 only
101	0010	82	Identified channel does not exist	Channel identity			DSS 1	Q.931	DSS1 only
101	0011	83	A suspended call exists, but this call identity does not				DSS 1	Q.931	DSS1 only

Cause		Definition		Diagnostics	Tone	R2MFC	Application (Note 1)	Reference (Note 2)	Remarks
Class	Value	Class	No.						
101	0100		84				DSS 1	Q.931	DSS1 only
101	0101		85				DSS 1	Q.931	DSS1 only
101	0110		86	Clearing cause			DSS 1	Q.931	DSS1 only
101	0111		87		NUT	B-5	ISUP, DSS 1	Q.735.1	CUG
101	1000		88	Incompatible parameter (DSS 1)	NUT	B-5	DSS 1, ISUP	Q.931	
				User-to-user indicators parameter name			ISUP	Q.737.1	UUS2
101	1010		90	Non-existent CUG	DSCT	B-4	ISUP	Q.735	CUG
101	1011		91	Invalid transit network selection	NUT	B-5	DSS 1, ISUP(NU)	Q.931	
101	1111		95	Invalid message, unspecified	NUT	B-5	DSS 1, ISUP	Annex A/Q.763	
110	0000		96	Mandatory information element is missing			DSS 1,	Q.931	
110	0001		97	Message type non-existent or not implemented	NUT	B-5	DSS 1, ISUP	Q.931 2.9.5.2/Q.764 2.9.5.3/Q.764	
110	0010		98	Message not compatible with call state or message type non-existent or not implemented			DSS 1	Q.931	DSS1 only
110	0011		99	Information element /parameter non-existent or not implemented	NUT	B-5	DSS 1, ISUP	2.9.5.2/Q.764 2.9.5.3/Q.764 Annex A/Q.763	
110	0100		100	Invalid information element contents			DSS 1	Q.931	DSS1 only
110	0101		101	Message not compatible with call state			DSS 1	Q.931	DSS1 only

Cause Class	Definition		Diagnostics	Tone	R2MFC	Application (Note 1)	Reference (Note 2)	Remarks
	Value	No.						
110	0110	102	Recovery on timer expiry	Timer number	DSCCT	B-4	DSS 1, ISUP	Terminal portability: expiry of waiting RES (user) timer. Not set by Telecom
							2.4.3/Q.764	Expiry of waiting RES (network) timer (incoming international exchange)
110	0111	103	Parameter non-existent or not implemented, passed on	Parameter name(s)	DSCCT	B-4	ISUP(NU)	Not set by Telecom
110	1110	110	Message with unrecognized parameter, discarded	Parameter name(s), message name	DSCCT	B-4	ISUP	Not set by Telecom
110	1111	111	Protocol error, unspecified		NUT	B-5	DSS 1, ISUP	Annex A/Q.763
111	1111	127	Interworking, unspecified		NUT	B-5	DSS 1, ISUP	Q.735.1 Annex A/Q.763

## NOTES

- 1 Application indicates that the cause value may be carried in DSS 1 and/or ISUP. Causes carried in ISUP which are not marked for national use (NU) are the minimum set of cause values that shall be supported over the international interface.
- 2 The references included are not exhaustive.
- 3 deleted
- 4 Locking and non-locking shift procedures described in 4.5/Q.931 are applied. In principle information element identifiers are ordered in the same order as the information element in the received message.
- 5 When only locking shift information element is included and no variable length information element identifier follows, it means that the codeset in the locking shift itself is not implemented.

**Q.850/2.2.6.4 Coding of Call rejected diagnostic**

The format of the diagnostic field for cause number 21 is as shown in Figure 2 and Table 2.

8	7	6	5	4	3	2	1	
1 ext.	Rejection reason					Condition		Octets x*
User specific diagnostic								x+1* etc. (Note 1)
IE type	Information element identifier							x+2* etc. (Note 2)

NOTES

- 1 This octet may be present only if octet x indicates user specific diagnostic.
- 2 This octet may be present only if octet x indicates information element missing or information element contents are not sufficient.

FIGURE 2/Q.850

**Coding of diagnostic field for cause number 21**

TABLE 2/Q.850

**Coding of diagnostic field for cause number 21**

<i>Rejection reason (octet x)</i>	
Bits	
<u>7 6 5 4 3</u>	
0 0 0 0 0	user specific
0 0 0 0 1	information element missing
0 0 0 1 0	information element contents are not sufficient
All other values are reserved	
<i>Condition (octet x)</i>	
Bits	
<u>2 1</u>	
0 0	unknown
0 1	permanent
1 0	transient
1 1	spare
<i>User specific diagnostic (octet x+1)</i>	
Coded according to the user specification, subject to the maximum length of the Cause information element.	
<i>Information element type (octet x+2)</i>	
Bit	
<u>8</u>	
0	variable length information element
1	fixed length information element
<i>Information element identifier (octet x+2)</i>	
Bits 7-1 encoded with the information element identifier of the missing or insufficient information element.	

**Q.850/2.2.6.5 Coding of New destination/Called party number (new)**

New destination is formatted as the called party number information element, including information element identifier. Transit network selection may also be included.

**Q.850/2.2.6.6 Coding of Facility identification/Rejected parameter**

The coding of facility identification is network dependent.

**Q.850/2.2.6.7 Coding of Attribute identity**

The coding of the attribute identity diagnostic is shown in Figure 3, Table 3a and Table 3b.

NOTE – Not generated by ISUP.

8	7	6	5	4	3	2	1	
0/1 ext.	Attribute number							Octet x
0/1 ext.	Rejected attribute							x+1
1 ext.	Available attribute							x+2

NOTES

- 1 When diagnostics information is provided, octet x and x+1 shall be present. Octet x+2 is optional.
- 2 Octets x-x+2 may be repeated to report multiple rejected attributes.
- 3 The extension bit (ext.) when coded 0, indicates that this diagnostic continues to the next octet.

FIGURE 3/Q.850

**Coding of the diagnostic field for causes number 57, 58 and 65  
(Attribute identity)**

TABLE 3A/Q.850

**Coding of attribute number field for causes number 57, 58 and 65**

<i>Attribute number (octet x)</i>		
Bits		
<u>7 6 5 4 3 2 1</u>	No.	
0 1 1 0 0 0 1	1	Information transfer capability
0 1 1 0 0 1 0	2	Information transfer mode
0 1 1 0 0 1 1	3	Information transfer rate
0 1 1 0 1 0 0	4	Structure
0 1 1 0 1 0 1	5	Configuration
0 1 1 0 1 1 0	6	Establishment
0 1 1 0 1 1 1	7	Symmetry
0 1 1 1 0 0 0	8	Information transfer rate (dest. ® orig.)
0 1 1 1 0 0 1	9	Layer identification

TABLE 3B/Q.850

**Coding of the rejected attribute field for causes number 57, 58 and 65**

Rejected attribute (octet x+1)	
Attribute No.	
1.	Information transfer capability: Bits 7-6: 00 Bits 5-1: according to Table 4-6/Q.931, octet 3
2.	Information transfer mode Bits 7-6: according to Table 4-6/Q.931, octet 4 Bits 5-1: 00000
3.	Information transfer rate Bits 7-6: 00 Bits 5-1 according to Table 4-6/Q.931, octet 4
4.	Structure (Note 1) Bits 7-5: according to Table 4-6/Q.931, octet 4a Bits 4-1: 0000
5.	Configuration (Note 1) Bits 7-4: 000 Bits 4-3: according to Table 4-6/Q.931, octet 4a Bits 2-1: 00
6.	Establishment (Note 1) Bits 7-3: 00000 Bits 2-1: according to Table 4-6/Q.931, octet 4a
7.	Symmetry (Note 1) Bits 7-6: according to Table 4-6/Q.931, octet 4b Bits 5-1: 00000
8.	Information transfer rate (dest. → orig.): (Note 1) Bits 7-6: 00 Bits 5-1: according to Table 4-6/Q.931, octet 4b
9.	Layer identification: Bits <u>7 6</u> _0 1 (layer 1) Bits 5-1 according to Table 4-6/Q.931, octet 5 1 0 (layer 2) Bits 5-1 according to Table 4-6/Q.931, octet 6 1 1 (layer 3) Bits 5-1 according to Table 4-6/Q.931, octet 7
10.	Rate Multiplier: Bit 8: 1 Bits 7-1 according to Table 4-6/Q.931, octet 4.1
Available attributes (octet x+2)	
The same coding as octet x+1	
NOTES	
1 These values were defined in Recommendation Q.931 (1988).	
2 A description of Table 4-6/Q.931 is found in 3.57.	

**Q.850/2.2.6.8 Coding of Channel type**

The channel type is coded as follows:

- Bit 8: Extension bit
- Bit 7-5: spare
- Bit 4-1: according to the Table 4-15/Q.931 octet 3.2, channel type.

NOTE – Not generated by ISUP.

**Q.850/2.2.6.9 Coding of Incompatible parameter**

Incompatible parameter is composed of incompatible information element identifier.

**Q.850/2.2.6.10 Coding of Timer number**

NOTE – Not generated by ISUP.

The timer number is coded in IA5 characters, e.g. T308 is coded as "3" "0" "8". The following coding is used in each octet:

- Bit 8: Spare "0"
- Bit 7-1: IA5 character.

**Q.850/2.2.6.11 Coding of Message type**

Message type is coded as specified in Table 4 and Table 4-2/Q.931, respectively.

**Q.850/2.2.6.12 Coding of parameter name**

Parameter name is coded as specified in Table 5/Q.763.

**3.13 Circuit group supervision message type**

3.11.1 This parameter is used in conjunction with circuit group blocking/unblocking messages to indicate the origin of the block/unblocking request.

3.11.2 Circuit Group Supervision Message Type Indicator is a mandatory fixed length parameter used in the following messages.

- Circuit Group Blocking (CGB) (ref. §4.24)
- Circuit Group Blocking Acknowledgement (CGBA) (ref. §4.24)
- Circuit Group Unblocking (CGU) (ref. §4.24)
- Circuit Group Unblocking Acknowledgement (CGUA) (ref. §4.24)

The format of the circuit group supervision message type parameter field is shown in Figure 14.

8	7	6	5	4	3	2	1
H	G	F	E	D	C	B	A

**Figure 14 – Circuit group supervision message type parameter field**

The following codes are used in the circuit group supervision message type parameter field:

bits



<u>BA</u>	Circuit group supervision message type indicator
0 0	maintenance oriented; <i>caused by input of circuit blocking command at the exchange</i>
0 1	hardware failure oriented; <i>caused by transmission system failure</i>
1 0	reserved for national use (used in 1984 version). <i>not used by Telecom. Mapped to 00 if received</i>
1 1	spare. <i>not used by Telecom</i>
bits H-C	spare <i>not used by Telecom</i>

### 3.14 Circuit state indicator (national use)

This section has not been reproduced as this parameter is not implemented.

### 3.15 Closed user group interlock code

This section has not been reproduced as this parameter is not implemented.

### 3.16 Connected number

This section has not been reproduced as this parameter is not implemented.

### 3.17 Connection request

This section has not been reproduced as this parameter is not implemented.

### 3.18 Continuity indicators

This section has not been reproduced as this parameter is not implemented.

### 3.19 Echo control information

This section has not been reproduced as this parameter is not implemented.

### 3.20 End of optional parameters

3.20.1 Where one or more optional parameters are present in a message the last parameter field of the message is followed by the end of optional parameters indicator, which occupies a one octet field containing all zeros.

The last optional parameter field of a message is followed by the end of optional parameters octet (see 1.8).

### 3.21 Event information

3.21.1 This parameter is used to indicate the type of event which caused a call progress message in the backward direction. An ISUP-ISUP transit exchange will pass the parameter on unchanged. An originating exchange will send the equivalent information to an ISDN calling party via access signalling.

3.21.2 Event Information is mandatory fixed length parameter used in the following message:

Call Progress (CPG) (ref. §4.4)

The format of the event information parameter field is shown in Figure 21.

8	7	6	5	4	3	2	1
H	G	F	E	D	C	B	A

**Figure 21 – Event information parameter field**

The following codes are used in the event indicator parameter field:

bits	
<u>GFEDCBA</u>	Event indicator
0 0 0 0 0 0	spare
0 0 0 0 0 1	ALERTING message received from the ISDN access
0 0 0 0 1 0	PROGRESS message received from the ISDN access
0 0 0 0 1 1	in-band information or an appropriate pattern is now available, <i>i.e.</i> , tones or messages
0 0 0 1 0 0	call forwarded on busy (national use)
0 0 0 1 0 1	call forwarded on no reply (national use)
0 0 0 1 1 0	call forwarded unconditional (national use)
0 0 0 1 1 1	spare (Note). Used within the Telecom network for special services; not used at the POI interface.
to	
1 1 1 1 1 1	

NOTE – Coding of this indicator is frozen; no additional codes can be defined for compatibility.

bit	
<u>H</u>	Event presentation restricted indicator (national use); <i>this field is used to indicate if the event which caused the progress message is to be passed back to the subscriber</i>
0	no indication; <i>set for all calls</i>
1	presentation restricted; <i>not set by Telecom</i>

### 3.22 Facility indicator

This section has not been reproduced as this parameter is not implemented.

### 3.23 Forward call indicators

3.23.1 This parameter is used to pass information indicating the type of call and some of its basic characteristics to the terminating exchange. It can be used by transit exchanges for routing and by terminating exchanges for barring. On receipt of a particular value of this parameter an ISUP-ISUP transit exchange will, in some circumstances, modify it to indicate call characteristics.

3.23.2 Forward Call Indicators is a mandatory fixed length parameter used in the following message:

Initial Address (IAM) (ref. §4.13)

3.23.3 The format of the forward call indicators parameter field is shown in Figure 23.

	8	7	6	5	4	3	2	1
1	H	G	F	E	D	C	B	A
2	P	O	N	M	L	K	J	I

**Figure 23 – Forward call indicators parameter field**

3.23.4 The following codes are used in the forward call indicators parameter field:

bit

- A National/international call indicator
- 0 call to be treated as a national call; *set on all calls originated in the Telecom network, or when the origin is not known*
- 1 call to be treated as an international call; *set on the first and subsequent contiguous ISUP stages beyond the international exchange for all incoming international calls*

This bit can be set to any value in the country of origin. In the international network this bit is not checked. In the destination country, calls from the international network will have this bit set to 1.

bits

- CB End-to-end method indicator (Note)
- 0 0 no end-to-end method available (only link-by-link method available); *set for all calls*
- 0 1 pass-along method available (national use); *not set by Telecom*
- 1 0 SCCP method available; *not set by Telecom*
- 1 1 pass-along and SCCP methods available (national use); *not set by Telecom*

bit

- D Interworking indicator (Note) (Note 2)
- 0 no interworking encountered (No. 7 signalling all the way) encountered; *set on the first and subsequent contiguous No.7 stages beyond the originating exchange to indicate that No.7 signalling has been used all the way*
- 1 interworking encountered; *set on first and subsequent No.7 stages following a non-No.7 signalling stage; also set after a call has been intercepted by an operator node*

bit

- E End-to-end information indicator (Note) (national use)
- 0 no end-to-end information available; *set for all calls*
- 1 end-to-end information available; *i.e., waiting transmission; not set by Telecom*

bit

- F ISDN user part indicator (Note) (Note 2)
- 0 ISDN user part not used all the way; *set on first and subsequent contiguous ISUP stages following a non-ISUP signalling stage; also set after a call has been intercepted by an operator node*
- 1 ISDN user part used all the way; *set on the first and subsequent contiguous ISUP stages beyond the originating exchange to indicate that ISUP signalling has been used all the way*

bits

<u>HG</u>	ISDN user part preference indicator
0 0	ISDN user part preferred all the way; <i>set on first and subsequent contiguous ISUP stages for all calls from ISDN lines</i>
0 1	ISDN user part not required all the way; <i>set for all calls from PSTN lines and for all calls beyond a non-ISUP signalling stage; also set after a call has been intercepted by an operator node</i>
1 0	ISDN user part required all the way; <i>set on first and subsequent contiguous ISUP stages for Wide Area Centrex calls that require ISUP</i>
1 1	spare; <i>not set by Telecom</i>

bit

<u>I</u>	ISDN access indicator
0	originating access non-ISDN; <i>set for calls from PSTN lines and for all calls beyond a non-ISUP signalling stage; also set after a call has been intercepted by an operator node</i>
1	originating access ISDN; <i>set on first and subsequent contiguous ISUP stages for all calls from ISDN lines</i>

bits

<u>KJ</u>	SCCP method indicator (Note)
0 0	no indication; <i>set for all calls</i>
0 1	connectionless method available (national use) ; <i>not set by Telecom</i>
1 0	connection oriented method available; <i>not set by Telecom</i>
1 1	connectionless and connection oriented methods available (national use) ; <i>not set by Telecom</i>

bit

<u>L</u>	Spare; <i>not set by Telecom</i>
----------	----------------------------------

bit

<u>M</u>	Reverse charge indicator
0	Not a reverse charge call
1	Reverse charge call. <i>Set for all calls beyond an operator for “collect” calls. This may be used only by agreement with the interconnect network operator. Otherwise always coded 0 when sent from a Telecom POI to another network. Ignored and converted to value 0 if received from another network.</i>

bit

<u>N</u>	Reserved for national use; Used to provide Telecom network services. Always coded 0 when sent from a Telecom POI to another network. Ignored and converted to value 0 if received from another network.
----------	---

bit

<u>O</u>	IN indicator
0	Not an IN call
1	IN call. Set for all calls following interaction with the Telecom Intelligent Network <i>This may be used only by agreement with the interconnect network operator.</i>

bit

<u>P</u>	Reserved for national use; Used to provide Telecom network services. Always coded 0 when sent from a Telecom POI to another network. Ignored and converted to value 0 if received from another network.
----------	---

NOTE – Bits B-F and J-K constitute the protocol control indicator.

*NOTE 2 – For calls originating in Telecom's network bits D and F convey identical information because ISUP is the only part of No.7 signalling used for call control. i.e. on first and subsequent links beyond a section of R2MFC or DP signalling bit D = 1 and bit F = 0*

### **3.24 Generic digits (national use)**

This section has not been reproduced as this parameter is not implemented.

### **3.25 Generic notification indicator**

This section has not been reproduced as this parameter is not implemented.

### **3.26 Generic notification indicator**

This section has not been reproduced as this parameter is not implemented.

### **3.27 Reserved (used in 1992 version)**

### **3.28 Information indicators (national use)**

This section has not been reproduced as this parameter is not implemented.

### **3.29 Information request indicators (national use)**

This section has not been reproduced as this parameter is not implemented.

### **3.30 Location number**

This section has not been reproduced as this parameter is not implemented.

### **3.31 MCID request indicators**

This section has not been reproduced as this parameter is not implemented.

### **3.32 MCID response indicators**

This section has not been reproduced as this parameter is not implemented.

### **3.33 Message compatibility information**

This section has not been reproduced as this parameter is not implemented.

### **3.34 MLPP precedence**

This section has not been reproduced as this parameter is not implemented.

### **3.35 Nature of connection indicators**

3.35.1 This parameter is used to indicate some of the physical characteristics of the inter-exchange traffic circuits used for the call. In the Telecom network its only use is to allow a transit exchange to base routing on whether a preceding stage of the call has used a satellite circuit.

3.35.2 Nature of Connection indicators is a mandatory fixed length parameter used in the following message:

Initial Address (IAM) (ref. §4.13)

The format of the nature of connection indicators parameter field is shown in Figure 36.

8	7	6	5	4	3	2	1
H	G	F	E	D	C	B	A

**Figure 36 – Nature of connection indicators parameter field**

The following codes are used in the nature of connection indicators parameter field:

bits

<u>BA</u>	Satellite indicator
0 0	no satellite circuit in the connection
0 1	one satellite circuit in the connection
1 0	two satellite circuits in the connection
1 1	spare; <i>not set by Telecom; mapped to value 10 if received</i>

bits

<u>DC</u>	Continuity check indicator
0 0	continuity check not required; <i>always set</i>
0 1	continuity check required on this circuit; <i>not set by Telecom</i>
1 0	continuity check performed on a previous circuit; <i>not set by Telecom</i>
1 1	spare; <i>not set by Telecom</i>

bit

<u>E</u>	Echo control device indicator
0	outgoing echo control device not included; <i>always set</i>
1	outgoing echo control device included; <i>not set by Telecom; passed transparently if received from another network at a POI</i>

bits F-H Spare; *set to value 0 by Telecom*

*Note 1 - The received value of satellite indicator is incremented by 1 (up to a maximum value of 2) when the outgoing circuit is via satellite.*

### **3.36 Network specific facility (national use)**

This section has not been reproduced as this parameter is not implemented.

### **3.37 Optional backward call indicators**

3.37.1 This parameter is used to pass information additional to that in the Backward Call Indicators Parameter (ref § 3.5) back to the originating No.7 exchange (i.e. in the direction from the terminating towards the originating exchange). The information may be used by the originating exchange to activate special facilities or may be mapped to the originating ISDN access. On receipt of a particular value of this parameter, an ISUP-ISUP transit exchange will in general pass the parameter on, unchanged.

3.37.2 Optional Backward Call Indicators is an optional parameter which may be used in the following messages (Note: it is normally included only if one or more of bits A, B or H is set to "1"):

Address Complete (ACM)	(ref. §4.2)
Answer (ANM)	(ref. §4.3)
Call Progress (CPG)	(ref. §4.4)
Connect (CON)	(ref. §4.8)

However, it is not used in the ANM and CON messages by Telecom.

Note: it is included in the ACM only in the following circumstances:

- Always, when the terminating line is non-ISDN (bit A=1, bits B, H as applicable).
- Always, when ISUP to non-ISUP interworking has been encountered (bit A=1, bits B, H as applicable).
- When the terminating line is ISDN and the conditions exist for setting any one or more of bits A, B or H to value 1.

The format and codes of the optional backward call indicators field is shown in Figure 38.

8	7	6	5	4	3	2	1
H	G	F	E	D	C	B	A

**Figure 38 – Optional backward call indicators parameter field**

The following codes are used in the optional backward call indicators parameter field:

bit

- A In-band information indicator
- 0 no indication; *set for calls where Transmission Medium Requirement parameter (ref. §3.54) in the IAM is set to 64kbit/s*
- 1 in-band information or an appropriate pattern is now available; *set for calls where Transmission Medium Requirement parameter (ref. §3.54) in the IAM is set to 3.1kHz audio or speech, to indicate that tones or announcements may be returned inband to the calling user*

Note: The information received in this indicator at the originating exchange will be passed to the ISDN access in an alerting or call progress message.

bit

- B Call diversion may occur indicator
- 0 no indication; *always set*
- 1 call diversion may occur; *not set by Telecom*

bit

- C Simple segmentation indicator
- 0 no additional information will be sent; *always set*
- 1 additional information will be sent in a segmentation message; *not set by Telecom*

bit

- D MLPP user indicator
- 0 no indication; *always set*
- 1 MLPP user; *not set by Telecom*

bits G-E Reserved for national use; *set to value 0 by Telecom*

bit H Reserved for national use; *Used in the Telecom network to provide special facilities. Coded "0" if sent from a Telecom POI to another network.*

**3.38 Optional forward call indicators**

This section has not been reproduced as this parameter is not implemented.

**3.39 Original called number**

3.39.1 This parameter is used in Call Diversion Supplementary service, to carry the identity of the number that was originally called. Refer to Appendix 5 for a description of the ISUP signals used when diverting calls. A terminating exchange receiving this parameter may pass it to the ISDN called party.

3.39.2 *The passing of redirecting information, including this parameter, at the POI is subject to agreement and is controlled by configuration data.*

3.39.3 Original Called Number is an optional parameter which may be used in the following message:

Initial Address (IAM) (ref. §4.13)

The format of the original called number parameter field corresponds to the format shown in Figure 40.

	8	7	6	5	4	3	2	1
1	Odd/ even	Nature of address indicator						
2	Spare	Numbering plan ind.			Address presentation restricted indicator		Spare	
3	2nd address signal				1st address signal			
.								
.								
n	Filler (if necessary)				nth address signal			

**Figure 40 – Original called number parameter field**

The following codes are used in the subfields of the original called number parameter field:

- a) *Odd/even indicator*: see 3.9.2 a).



b) *Nature of address indicator:*

0 0 0 0 0 0	spare; <i>not set by Telecom</i>
0 0 0 0 0 1	subscriber number (national use) ; <i>not set by Telecom</i>
0 0 0 0 1 0	unknown (national use)
0 0 0 0 1 1	national (significant) number (national use); ( <i>recommended setting</i> )
0 0 0 1 0 0	international number; <i>not set by Telecom but passed on if received from another country</i>
0 0 0 1 0 1	
to	spare; <i>not set by Telecom</i>
1 1 0 1 1 1	
1 1 1 0 0 0	
to	reserved for national use; <i>not set by Telecom</i>
1 1 1 1 1 0	
1 1 1 1 1 1	spare; <i>not set by Telecom</i>

c) *Numbering plan indicator:* see 3.9.2 d).d) *Address presentation restricted indicator:* see 3.10.4 e).e) *Address signal:* see 3.10.4 g).f) *Filler:* see 3.9.2 f).**3.40 Origination ISC point code**

This section has not been reproduced as this parameter is not implemented.

**3.41 Parameter compatibility information**

This section has not been reproduced as this parameter is not implemented.

**3.42 Propagation delay counter**

This section has not been reproduced as this parameter is not implemented.

**3.43 Range and status**

3.43.1 This parameter is used to indicate the range of circuits, and to identify specific circuits within that range, affected by the message in which the parameter appears.

3.43.2 Range and Status is a mandatory variable length parameter used in the following messages (known as circuit group supervision messages) which are used between exchanges to block and idle groups of traffic circuits:

Circuit Group Blocking (CGB)	(ref. §4.24)
Circuit Group Blocking Acknowledgement (CGBA)	(ref. §4.24)
Circuit Group Unblocking (CGU)	(ref. §4.24)
Circuit Group Unblocking Acknowledgement(CGUA)	(ref. §4.24)
Circuit Group Reset (GRS)	(ref. §4.25)
Circuit Group Reset Acknowledgement(GRA)	(ref. §4.6)

It is also used in the following messages neither of which is used by Telecom:

Circuit Group Query (CGM)	(ref. §4.26)
Circuit Group Query Response (CQR)	(ref. §4.5)

The format of the range and status parameter field is shown in Figure 43.

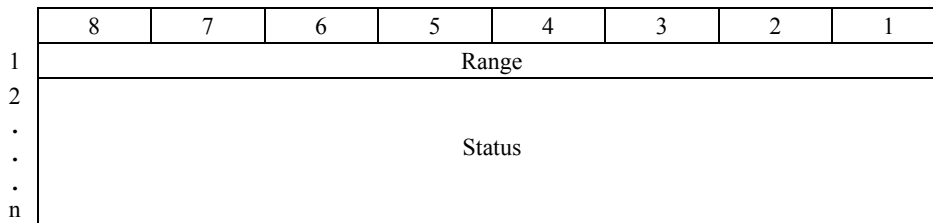

**Figure 43 – Range and status parameter field**

The following codes are used in the subfields of the range and status parameter field:

a) *Range*

A number in pure binary representation ranging from 0 to 255 (1 to 255 for Telecom). The number represented by the range code + 1 indicates the range of circuits affected by the message.

The number of circuits affected by a group supervision message is limited to 32 or less. For the group reset messages, a circuit group query message, or a circuit query response message, this requires that the range value be 31 or less. For the group blocking and unblocking messages the range value may be up to 255, but the number of status bits set to 1 must be 32 or less.

For the group blocking, unblocking and reset messages, range code 0 is reserved. Range code 0 is exclusively used by the circuit query and circuit query response messages.

*The range field value of 0 (allowed only in the CQM and CQR messages, which are not used by Telecom) means the message applies only to the circuit identified by the CIC parameter. In this case the status field will not be present.*

If a range field value of zero or a range value greater than 31 is received, the Telecom network will ignore the group message; no response will be given.

b) *Status*

The status subfield contains from 2 to 256 status bits numbered from 0 to 255. Status bit 0 is located in bit position 1 of the first status subfield octet. Other status bits follow in numerical order. The number of relevant status bits in a given status subfield is equal to range + 1.

Each status bit is associated with a circuit identification code such that status bit n is associated with circuit identification code m + n, where m is the circuit identification code contained in the message.

The status bits are coded as follows:

- in circuit group blocking (CGB) messages
  - 0 no indication; (no action required)
  - 1 blocking; (circuit is to be blocked)

- in circuit group blocking acknowledgement (CGBA) messages
  - 0 no indication; *(no action taken)*
  - 1 blocking acknowledgement; *(circuit has been blocked)*
- in circuit group unblocking (CGU) messages
  - 0 no indication; *(no action required)*
  - 1 unblocking; *(circuit is to be made idle)*
- in circuit group unblocking acknowledgement (CGUA) messages
  - 0 no indication; *(no action taken)*
  - 1 unblocking acknowledgement; *(circuit has been released)*
- in circuit group reset acknowledgement (GRA) messages
  - 0 not blocked for maintenance reasons; *(i.e. available for service or blocked for hardware failure reasons)*
  - 1 blocked for maintenance reasons; *(circuit is to stay blocked); i.e. When a reset message is received for a group of circuits requesting that some circuits already blocked for maintenance reasons be reset (made idle), the Reset Acknowledgement message will advise the exchange originating the reset that these particular circuits must remain blocked.*

### 3.44 Redirecting number

3.44.1 This parameter is used in call diversion supplementary service and call rerouting (not used by Telecom) to pass forward the number from which the call was last diverted. Refer to Appendix 5 for a description of the ISUP signals used when diverting calls.

3.44.2 *The passing of redirecting information, including this parameter, at the POI is subject to agreement with the interconnect network operator and is controlled by configuration data.*

3.44.3 *If the POI has been set to pass redirection information, then the Redirecting number parameter must be included for calls that have been redirected one or more times.*

3.44.4 *If the POI has been set to not pass redirection information, and the Redirecting number parameter is present within Telecom's network, the Calling party number parameter will be set to the contents of the Redirecting number parameter before the call is passed to the POI.*

3.44.5 Redirecting Number is an optional parameter which may be used in the following message:

Initial Address (IAM) (ref. §4.13)

The format of the redirecting number parameter field corresponds to the format shown in Figure 40.

The following codes are used in the subfields of the redirecting number parameter field:

- a) Odd/even indicator: see 3.9.2 a)

b) Nature of address indicator:

0 0 0 0 0 0	spare; <i>not set by Telecom</i>
0 0 0 0 0 1	subscriber number (national use); <i>not set by Telecom</i>
0 0 0 0 1 0	unknown (national use); <i>not set by Telecom</i>
0 0 0 0 1 1	national (significant) number (national use); <i>(recommended setting)</i>
0 0 0 1 0 0	international number; <i>may be received on incoming international calls</i>
0 0 0 1 0 1	
to	spare; <i>not set by Telecom</i>
1 1 0 1 1 1	
1 1 1 0 0 0	
to	reserved for national use; <i>not set by Telecom</i>
1 1 1 1 1 0	
1 1 1 1 1 1	spare; <i>not set by Telecom</i>

- c) Numbering plan indicator: see 3.9.2 d)
- d) Address presentation restricted indicator: see 3.10.4 e)
- e) Address signal: see 3.10.4 g)
- f) Filler: see 3.9.2 f).

**3.45 Redirection information**

3.45.1 This parameter is used to pass information associated with call diversion supplementary service and call rerouting (not used by Telecom) in either the forward or backward direction (not used by Telecom). Refer to Appendix 5 for a description of the ISUP signals used when diverting calls.

3.45.2 The passing of redirecting information, including this parameter, at the POI is subject to agreement with the interconnect network operator and is controlled by configuration data.

3.45.3 Redirection Information is an optional parameter which may be used in the following messages:

- Initial Address (IAM) (ref. §4.13)
- Release (REL) (ref. §4.14)

However, it is not used in the REL message by Telecom.

The format of the redirection information parameter field is shown in Figure 44.

	8	7	6	5	4	3	2	1
1	H	G	F	E	D	C	B	A
2	P	O	N	M	L	K	J	I
<p>Note – The parameter may be received without the second octet from an ISUP'88 network This is not applicable at the Telecom POI; both octets must be included.</p>								

**Figure 44 – Redirection information parameter field**

The following codes are used in the redirection information parameter field:

bits

<u>CBA</u>	Redirecting indicator
0 0 0	no redirection (national use)
0 0 1	call rerouted (national use) ; <i>not set by Telecom</i>
0 1 0	call rerouted, all redirection information presentation restricted (national use) ; <i>all redirection information presentation; not set by Telecom</i>
0 1 1	call diverted
1 0 0	call diverted, all redirection information presentation restricted
1 0 1	call rerouted, redirection number presentation restricted (national use) ; <i>not set by Telecom</i>
1 1 0	call diversion, redirection number presentation restricted (national use)
1 1 1	spare; <i>not set by Telecom</i>
bit D	Spare; <i>set to value 0 by Telecom</i>

bits

<u>HGFE</u>	Original redirection reason
0 0 0 0	unknown/not available
0 0 0 1	user busy (national use)
0 0 1 0	no reply (national use)
0 0 1 1	unconditional (national use)
0 1 0 0	to spare; <i>not set by Telecom</i>
1 1 0 1	spare; <i>queue overflow; used by Telecom but not passed to other networks at the POI</i>
1 1 1 0	spare; <i>queue overflow; used by Telecom but not passed to other networks at the POI</i>
1 1 1 1	spare; <i>not set by Telecom</i>

bits

K J I Redirection counter. Number of redirections the call has undergone expressed as a binary number between 1 and 5.

bit L Reserved for national use

bits

<u>PONM</u>	Redirecting reason
0 0 0 0	unknown/not available
0 0 0 1	user busy
0 0 1 0	no reply
0 0 1 1	unconditional
0 1 0 0	deflection during alerting; <i>not set by Telecom</i>
0 1 0 1	deflection immediate response; <i>not set by Telecom</i>
0 1 1 0	mobile subscriber not reachable; <i>not set by Telecom</i>
0 1 1 1	to spare; <i>not set by Telecom</i>
1 1 0 1	spare; <i>queue overflow; used by Telecom but not passed to other networks at the POI</i>
1 1 1 0	spare; <i>queue overflow; used by Telecom but not passed to other networks at the POI</i>
1 1 1 1	spare; <i>not set by Telecom</i>

### 3.46 Redirection number

3.46.1 This parameter is used to pass information associated with call diversion supplementary service and call rerouting in either the forward or backward direction.

3.46.2 *The passing of redirecting information, including this parameter, at the POI is subject to agreement with the interconnect network operator and is controlled by configuration data.*

3.46.3 Redirection Information is an optional parameter which may be used in the following messages:

Address Complete (ACM)	(ref. §4.2)
Answer (ANM)	(ref. §4.3)
Call Progress (CPG)	(ref. §4.4)
Release (REL)	(ref. §4.14)

However, it is not used in the REL message by Telecom at the POI.

The format of the redirection number parameter field corresponds to the format shown in Figure 10.

The following codes are used in the subfields of the redirection number parameter field:

- a) Odd/even indicator: see 3.9.2 a).
- b) Nature of address indicator:

0 0 0 0 0 0	spare; <i>not set by Telecom</i>
0 0 0 0 0 1	subscriber number (national use); <i>not set by Telecom</i>
0 0 0 0 1 0	unknown (national use); <i>normally set by Telecom</i>
0 0 0 0 1 1	national (significant) number (national use); <i>not set by Telecom</i>
0 0 0 1 0 0	international number; <i>may be received on outgoing international calls</i>
0 0 0 1 0 1	
to	spare; <i>not set by Telecom</i>
1 1 0 1 1 1	
1 1 1 0 0 0	
to	reserved for national use; <i>not set by Telecom</i>
1 1 1 1 1 0	
1 1 1 1 1 1	spare; <i>not set by Telecom</i>

- c) Internal network number indicator: see 3.9.2 c).
- d) Numbering plan indicator: see 3.9.2 d).
- e) Address signal: see 3.10.4 g).
- f) Filler: see 3.9.2 f).

### 3.47 Redirection number restriction

This section has not been reproduced as this parameter is not implemented.

### 3.48 Remote operations (national use)

This section has not been reproduced as this parameter is not implemented.

### 3.49 Service activation

This section has not been reproduced as this parameter is not implemented.

**3.50 Signalling point code (national use)**

3.50.1 This parameter is sent in either or both directions during call release to identify the exchange (by its signalling point code) which initiated the release procedure.

3.50.2 Signalling Point Code is an optional parameter which may be used in the following message:

Release (REL) (ref. §4.14)

*However, this parameter is included in all release messages sent by the Telecom POI exchange to other networks, and is required to be included in all release messages sent to the Telecom POI exchange by other networks.*

The format of the signalling point code parameter field is shown in Figure 50.

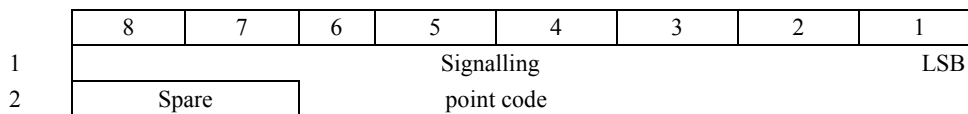

**Figure 50 – Signalling point code parameter field**

**3.51 Subsequent number**

This section has not been reproduced as this parameter is not implemented.

**3.52 Suspend/resume indicators**

3.52.1 This parameter can be used to indicate whether:

- a) the suspension of a call was initiated:
- i) by an ISDN user, or
  - ii) by the network (not set by Telecom),

and

- b) the resumption of the call was initiated:
- i) by an ISDN user, or
  - ii) by a PSTN user (set by Telecom but not sent from the Telecom POI to another network), or
  - iii) by the network (not set by Telecom).

3.52.2 Suspend/Resume indicators is a mandatory fixed length parameter used in the following messages:

Suspend (SUS) (ref. §4.20)

Resume (RES) (ref. §4.21)

The format of the suspend/resume indicators parameter field is shown in Figure 52.

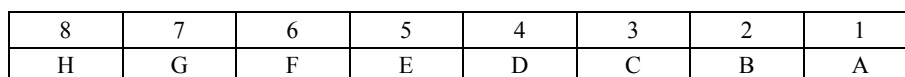

**Figure 52 – Suspend/resume indicators parameter field**

The following codes are used in the suspend/resume indicators parameter field:

bit	
<u>A</u>	Suspend/resume indicator
0	ISDN subscriber initiated; <i>always set</i>
1	network initiated; <i>not set by Telecom. If received in a SUS message from another network the call may be released.</i>
bits H-B	Spare; <i>set to value 0 by Telecom</i>

### 3.53 Transit network selection (national use)

This section has not been reproduced as this parameter is not implemented.

### 3.54 Transmission medium requirement

3.54.1 This parameter is used to indicate the type of transmission bearer capability requested (or implied) by the calling party for the call.

3.54.2 Transmission Medium Requirements Indicators is a mandatory fixed length parameter used in the following message:

Initial Address (IAM) (ref. §4.13)

The format of the transmission medium requirement parameter field is shown in Figure 54.

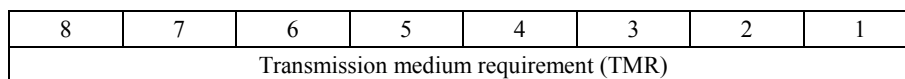

**Figure 54 – Transmission medium requirement parameter field**

The following codes are used in the transmission medium requirement parameter field:

0 0 0 0 0 0 0 0	speech; <i>set for speech calls from ISDN lines only (see ITU-T Recommendation I.530 [11])</i>
0 0 0 0 0 0 0 1	spare; <i>not set by Telecom</i>
0 0 0 0 0 0 1 0	64 kbit/s unrestricted; <i>set for ISDN unrestricted 64 kbit/s calls</i>
0 0 0 0 0 0 1 1	3.1 kHz audio; <i>set for ISDN audio and all PSTN calls (see ITU-T Recommendation I.530)</i>
0 0 0 0 0 1 0 0	reserved for alternate speech (service 2)/64 kbit/s unrestricted (service 1); <i>not set by Telecom</i>
0 0 0 0 0 1 0 1	reserved for alternate 64 kbit/s unrestricted (service 1)/speech (service 2); <i>not set by Telecom</i>
0 0 0 0 0 1 1 0	64 kbit/s preferred; <i>not set by Telecom</i>
0 0 0 0 0 1 1 1	2 × 64 kbit/s unrestricted; <i>not set by Telecom</i>
0 0 0 0 1 0 0 0	384 kbit/s unrestricted; <i>not set by Telecom</i>
0 0 0 0 1 0 0 1	1536 kbit/s unrestricted; <i>not set by Telecom</i>
0 0 0 0 1 0 1 0	1920 kbit/s unrestricted; <i>not set by Telecom</i>
0 0 0 0 1 0 1 1	
to	spare; <i>not set by Telecom</i>
0 0 0 0 1 1 1 1	
0 0 0 1 0 0 0 0	3 × 64 kbit/s unrestricted; <i>not set by Telecom</i>
0 0 0 1 0 0 0 1	4 × 64 kbit/s unrestricted; <i>not set by Telecom</i>
0 0 0 1 0 0 1 0	5 × 64 kbit/s unrestricted; <i>not set by Telecom</i>
0 0 0 1 0 0 1 1	spare; <i>not set by Telecom</i>



00010100	7 × 64 kbit/s unrestricted; <i>not set by Telecom</i>
00010101	8 × 64 kbit/s unrestricted; <i>not set by Telecom</i>
00010110	9 × 64 kbit/s unrestricted; <i>not set by Telecom</i>
00010111	10 × 64 kbit/s unrestricted; <i>not set by Telecom</i>
00011000	11 × 64 kbit/s unrestricted; <i>not set by Telecom</i>
00011001	12 × 64 kbit/s unrestricted; <i>not set by Telecom</i>
00011010	13 × 64 kbit/s unrestricted; <i>not set by Telecom</i>
00011011	14 × 64 kbit/s unrestricted; <i>not set by Telecom</i>
00011100	15 × 64 kbit/s unrestricted; <i>not set by Telecom</i>
00011101	16 × 64 kbit/s unrestricted; <i>not set by Telecom</i>
00011110	17 × 64 kbit/s unrestricted; <i>not set by Telecom</i>
00011111	18 × 64 kbit/s unrestricted; <i>not set by Telecom</i>
00100000	19 × 64 kbit/s unrestricted; <i>not set by Telecom</i>
00100001	20 × 64 kbit/s unrestricted; <i>not set by Telecom</i>
00100010	21 × 64 kbit/s unrestricted; <i>not set by Telecom</i>
00100011	22 × 64 kbit/s unrestricted; <i>not set by Telecom</i>
00100100	23 × 64 kbit/s unrestricted; <i>not set by Telecom</i>
00100101	spare; <i>not set by Telecom</i>
00100110	25 × 64 kbit/s unrestricted; <i>not set by Telecom</i>
00100111	26 × 64 kbit/s unrestricted; <i>not set by Telecom</i>
00101000	27 × 64 kbit/s unrestricted; <i>not set by Telecom</i>
00101001	28 × 64 kbit/s unrestricted; <i>not set by Telecom</i>
00101010	29 × 64 kbit/s unrestricted; <i>not set by Telecom</i>
00101011	
to	spare; <i>not set by Telecom</i>
11111111	

*Note – If a received value of this parameter is not one of the values set by Telecom the call may be released with cause value 35.*

### 3.55 Transmission medium requirement prime

This section has not been reproduced as this parameter is not implemented.

### 3.56 Transmission medium used

This section has not been reproduced as this parameter is not implemented.

### 3.57 User service information

3.57.1 This parameter is used to enable the originating ISDN subscriber to advise the terminating subscriber the transmission protocol to be used. It is also used by some networks that may not be able to support 64kbit/s unrestricted data transmission. At the originating exchange it is coded directly from the Bearer Capability information element in the ISDN access. At the terminating exchange it is mapped to the Bearer Capability information element in the ISDN access. Exchanges in the Telecom network treat this parameter transparently, i.e. they do not use it for routing.

3.57.2 User Service Information is an optional parameter which may be used in the following message:

Initial Address (IAM) (ref. §4.13)

The format of the user service information parameter field is shown in Figure 55. This format is the same as the Bearer capability information element from Recommendation Q.931 and not all

capabilities coded here are supported at this time. Refer to Telecom publication TNA 134, §4.5.5 for details. Also note that:

- (1) Information transfer rates other than 64 kbit/s are not applicable on calls to or from Telecom's POI exchange and another network.
- (2) Transfer Mode coded "packet mode" is not applicable on calls to or from Telecom's POI exchange and another network.
- (3) In the Telecom network, calls coded "packet mode" on the originating ISDN access are handled by the Telecom packet network.
- (4) *The User service information parameter shall be present in all calls from ISDN lines where the Forward call indicator sets bit I (ISDN access indicator) to Originating access ISDN. If the User service information parameter is absent in this case, call processing may be undetermined.*
- (5) *The User service information parameter shall be absent in all calls from non-ISDN lines where the Forward call indicator sets bit I (ISDN access indicator) to Originating access non-ISDN. If the User service information parameter is present in this case, call processing may be undetermined.*

	8	7	6	5	4	3	2	1
1	ext.	Coding standard			Information transfer capability			
2	ext.	Transfer mode			Information transfer rate			
2a	Rate multiplier							
3	ext.	Layer ident.			User information layer 1 protocol			
4	ext.	Layer ident.			User information layer 2 protocol			
5	ext.	Layer ident.			User information layer 3 protocol			

NOTE 1 – Octet 2a is required if octet 2 indicates multirate (64 kbit/s base rate); otherwise, it shall not be present.

NOTE 2 – Octets 3, 4, 5 or any combination of these octets may be omitted. Octet 3 may be extended as described in Recommendation Q.931.

**Figure 55 – User service information parameter field**

The codes to be used in the subfields of the user service information parameter field is defined in the Bearer capability information element in Recommendation Q.931.

### **3.58 User service information prime**

This section has not been reproduced as this parameter is not implemented.

### **3.59 User teleservice information**

This section has not been reproduced as this parameter is not implemented.

### **3.60 User-to-user indicators**

This section has not been reproduced as this parameter is not implemented.

**3.61 User-to-user information**

3.61.1 This parameter is used to transport information directly from one ISDN user to another. An ISUP-ISUP transit exchange will pass the parameter on, unchanged.

3.61.2 User-to-user Information is an optional parameter which may be used in the following messages:

Initial Address (IAM)	(ref. §4.13)
Answer (ANM)	(ref. §4.3)
Call Progress (CPG)	(ref. §4.4)
Connect (CON)	(ref. §4.8)
Release (REL)	(ref. §4.14)

It may also be used in the following messages, however Telecom does not do so:

Address Complete (ACM)	(ref. §4.2)
Segmentation (SGM)	(ref. §4.34)
User to User Information (USR)	(ref. §4.17)

3.61.3 The format of the user-to-user information parameter is shown in Figure 58.

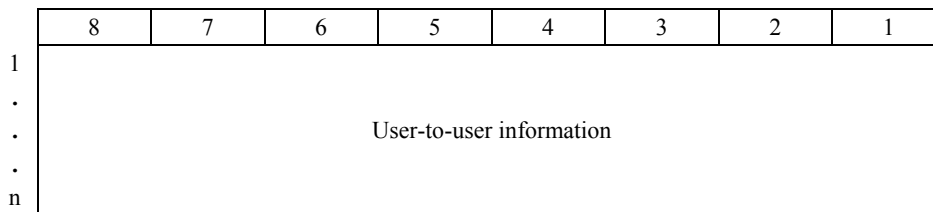

**Figure 58 – User-to-user information parameter field**

3.61.4 The format of the user-to-user information parameter field is coded identically to the protocol discriminator plus user information field described in Recommendation Q.931. *The maximum permitted length of this parameter is constrained by the maximum permitted MSU length and its other contents.*

**3.62 Backward GVNS**

This section has not been reproduced as this parameter is not implemented.

**3.63 CCSS**

This section has not been reproduced as this parameter is not implemented.

**3.64 Call transfer number**

This section has not been reproduced as this parameter is not implemented.

**3.65 Call transfer reference**

This section has not been reproduced as this parameter is not implemented.

### **3.66 Forward GVNS**

This section has not been reproduced as this parameter is not implemented.

### **3.67 Loop prevention indicators**

This section has not been reproduced as this parameter is not implemented.

### **3.68 Network management controls**

This section has not been reproduced as this parameter is not implemented.

### **3.69 Circuit assignment map**

This section has not been reproduced as this parameter is not implemented.

### **3.70 Correlation id**

This section has not been reproduced as this parameter is not implemented.

### **3.71 SCF id**

This section has not been reproduced as this parameter is not implemented.

### **3.72 Call diversion treatment indicators**

This section has not been reproduced as this parameter is not implemented.

### **3.73 Called IN number**

This section has not been reproduced as this parameter is not implemented.

### **3.74 Call offering treatment indicators**

This section has not been reproduced as this parameter is not implemented.

### **3.75 Charged party identification (national use)**

This section has not been reproduced as this parameter is not implemented.

### **3.76 Conference treatment indicators**

This section has not been reproduced as this parameter is not implemented.

### **3.77 Display information**

This section has not been reproduced as this parameter is not implemented.

### **3.78 UID action indicators**

This section has not been reproduced as this parameter is not implemented.

### **3.79 UID capability indicators**

This section has not been reproduced as this parameter is not implemented.

### **3.80 Hop counter**

This section has not been reproduced as this parameter is not implemented.

### 3.81 Collect call request

This section has not been reproduced as this parameter is not implemented.

## 4 ISDN user part messages and codes

### 4.1 General

4.1.1 In Tables 21 to 50, the format and coding of ISDN user part messages are specified. For each message, a list of the relevant parameters is given and for each parameter:

- a reference to the subclause where the formatting and coding of the parameter content is specified;
- the type of the parameter.

The following types are used in the tables:

F = mandatory fixed length parameter;

V = mandatory variable length parameter;

O = optional parameter of fixed or variable length;

- the length of the parameter.

The value in the table includes:

- for type F parameters: the length, in octets, of the parameter content;
- for type V parameters: the length, in octets, of the length indicator and of the parameter content. The minimum and the maximum length are indicated;
- for type O parameters: the length, in octets, of the parameter name, length indicator and parameter content. For variable length parameters the minimum and maximum length is indicated.

4.1.2 For each message type, type F parameters and the pointers for the type V parameters must be sent in the order specified in these tables. *Although optional parameters can be received and handled in any order, messages originating in Telecom's network will always include such parameters in the order depicted in the message formats shown in Tables 21 to 50.*

4.1.3 The routing label and circuit identification code fields, which are transmitted ahead of the message type field if required, are not shown. Parameter names, pointers to mandatory variable fields and the optional part, and length indicators appear in the message in accordance with Figure 3 and are not shown explicitly in Tables 21 to 50.

### 4.2 Address Complete Message

4.2.1 This is a backward message indicating that sufficient information has been received to complete the connection. It also provides information on the progress of the call including some terminating subscriber category information if available.

4.2.2 For calls using ISUP all the way, the ACM is generated at the terminating exchange and sent to the preceding exchange. At each transit exchange in the connection an ACM is sent back when an associated ACM is received from the succeeding exchange.

4.2.3 For calls where an R2MFC link follows an ISUP link the ACM is sent when an A-6, B-1, B-6, B-7, B-9, or B-10 signal is received at the ISUP-R2MFC exchange.

4.2.4 For calls where a DP link follows an ISUP link the ACM is sent when the IAM has been received at the ISUP-DP exchange.

4.2.5 The format of the ACM is shown in Table 21.

**Table 21**

**Message Type: Address complete**

Parameter	Reference (subclause)	Type	Length (octets)
Message type	2.1	F	1
Backward call indicators	3.5	F	2
Optional backward call indicators	3.37	O	3
Call reference (national use)	3.8	O	7
Cause indicators	3.12	O	4-?
User-to-user indicators	3.60	O	3
User-to-user information	3.61	O	3-131
Access transport	3.3	O	3-?
Generic notification indicator (Note 1)	3.25	O	3
Transmission medium used	3.56	O	3
Echo control information	3.19	O	3
Access delivery information	3.2	O	3
Redirection number (Note 2)	3.46	O	5-12
Parameter compatibility information	3.41	O	4-?
Call diversion information	3.6	O	3
Network specific facility (national use)	3.36	O	4-?
Remote operations (national use)	3.48	O	8-?
Service activation	3.49	O	3-?
Redirection number restriction indicator	3.47	O	3
Conference treatment indicators	3.76	O	3-?
UID action indicators	3.78	O	3-?
End of optional parameters	3.20	O	1
NOTE 1 – This parameter may be repeated.			
NOTE 2 – Peer-to-peer interworking with an earlier version of ISUP may result in format errors and lead to the release of the call.			

**4.3 Answer**

4.3.1 This is a backward message indicating that the called subscriber has answered.

4.3.2 The ANM is sent in response to the called subscriber answering or in response to receiving an answer signal from the succeeding exchange.

4.3.3 Receipt of the ANM at the originating exchange causes the transmission path for the relevant inter-exchange circuit to be through-connected in the forward direction. It also starts the call charging process (where relevant).

4.3.4 The format of the ANM is shown in Table 22.

**Table 22**

**Message Type: Answer**

Parameter	Reference (subclause)	Type	Length (octets)
Message type	2.1	F	1
Backward call indicators	3.5	O	4
Optional backward call indicators	3.37	O	3
Call reference (national use)	3.8	O	7
User-to-user indicators	3.60	O	3
User-to-user information	3.61	O	3-131
Connected number (Note 2)	3.16	O	4-?
Access transport	3.3	O	3-?
Access delivery information	3.2	O	3
Generic notification indicator (Note 1)	3.25	O	3
Parameter compatibility information	3.41	O	4-?
Backward GVNS	3.62	O	3-?
Call history information	3.7	O	4
Generic number (Notes 1 and 2)	3.26	O	5-?
Transmission medium used	3.56	O	3
Network specific facility (national use)	3.36	O	4-?
Remote operations (national use)	3.48	O	8-?
Redirection number (Note 2)	3.46	O	5-12
Service activation	3.49	O	3-?
Echo control information	3.19	O	3
Redirection number restriction indicator	3.47	O	3
Display information	3.77	O	3-?
End of optional parameters	3.20	O	1
NOTE 1 – This parameter may be repeated.			
NOTE 2 – Peer-to-peer interworking with an earlier version of ISUP may result in format errors and lead to the release of the call.			

#### 4.4 Call Progress (CPG)

4.4.1 This is a backward message which may be used to pass information on the progress of the call back to the originating ISDN access.

4.4.2 The information sent may be in response to indications received from the terminating ISDN access or in response to actions taken by the switch such as in the case of call forwarding.

4.4.3 The format of the CPG message is shown in Table 23.

**Table 23**

**Message Type: Call progress**

Parameter	Reference (subclause)	Type	Length (octets)
Message type	2.1	F	1
Event information	3.21	F	1
Cause indicators	3.12	O	4-?
Call reference (national use)	3.8	O	7
Backward call indicators	3.5	O	4
Optional backward call indicators	3.37	O	3
Access transport	3.3	O	3-?
User-to-user indicators	3.60	O	3
Redirection number (Note 2)	3.46	O	5-12
User-to-user information	3.61	O	3-131
Generic notification indicator (Note 1)	3.25	O	3
Network specific facility (national use)	3.36	O	4-?
Remote operations (national use)	3.48	O	8-?
Transmission medium used	3.56	O	3
Access delivery information	3.2	O	3
Parameter compatibility Information	3.41	O	4-?
Call diversion information	3.6	O	3
Service activation	3.49	O	3-?
Redirection number restriction indicator	3.47	O	3
Call transfer number (Note 2)	3.64	O	4-?
Echo control information	3.19	O	3
Connected number (Note 2)	3.16	O	4-?
Backward GVNS	3.62	O	3-?
Generic number (Notes 1 and 2)	3.26	O	5-?
Call history information	3.7	O	4
Conference treatment indicators	3.76	O	3-?
UID action indicators	3.78	O	3-?
End of optional parameters	3.20	O	1

NOTE 1 – This parameter may be repeated.

NOTE 2 – Peer-to-peer interworking with an earlier version of ISUP may result in format errors and lead to the release of the call.

**4.5 Circuit Group Query Response (CQR)**

This section has not been reproduced as this message is not implemented.



## 4.6 Circuit Group Reset Acknowledgement

4.6.1 This message, in combination with the Circuit Group Reset (GRS) message (refer § 4.25 in this part) is used to reset circuits to the idle state following exchange software initialisation at one end of the inter exchange circuits.

4.6.2 The GRA message is sent in response to a GRS message to confirm that circuits are being made idle as requested.

4.6.3 The format of the GRA message is shown in Table 25.

**Table 25**

### Message Type: Circuit group reset acknowledgement

Parameter	Reference (subclause)	Type	Length (octets)
Message type	2.1	F	1
Range and status	3.43	V	3-34

## 4.7 Confusion (CFN)

4.7.1 This message is used when it is necessary to advise the preceding exchange that an unrecognisable parameter has been received.

4.7.2 The format of the CFN message is shown in Table 26.

**Table 26**

### Message Type: Confusion

Parameter	Reference (subclause)	Type	Length (octets)
Message type	2.1	F	1
Cause indicators	3.12	V	3-?
End of optional parameters	3.20	O	1

## 4.8 Connect Message (CON)

4.8.1 This is a backward message indicating that sufficient information has been received and that the called subscriber has answered. It serves as both an ACM and an ANM.

4.8.2 Receipt of the CON at the originating exchange causes the transmission path for the relevant inter-exchange circuit to be through-connected in the forward direction. It also starts the call charging process (where relevant).

4.8.3 *This message is not originated by Telecom's exchanges, however they are able to receive and interpret it. It will be passed transparently if received from another network (e.g. from the international network).*

4.8.4 The format of the CON message is shown in Table 27.

**Table 27**

**Message Type: Connect**

<b>Parameter</b>	<b>Reference (subclause)</b>	<b>Type</b>	<b>Length (octets)</b>
Message type	2.1	F	1
Backward call indicators	3.5	F	2
Optional backward call indicators	3.37	O	3
Backward GVNS	3.62	O	3-?
Connected number (Note 2)	3.16	O	4-?
Call reference (national use)	3.8	O	7
User-to-user indicators	3.60	O	3
User-to-user information	3.61	O	3-131
Access transport	3.3	O	3-?
Network specific facility (national use)	3.36	O	4-?
Generic notification indicator (Note 1)	3.25	O	3
Remote operations (national use)	3.48	O	8-?
Transmission medium used	3.56	O	3
Echo control information	3.19	O	3
Access delivery information	3.2	O	3
Call history information	3.7	O	4
Parameter compatibility information	3.41	O	4-?
Service activation	3.49	O	3-?
Generic number (Notes 1 and 2)	3.26	O	5-?
Redirection number restriction indicator	3.47	O	3
Conference treatment indicators	3.76	O	3-?
End of optional parameters	3.20	O	1

NOTE 1 – This parameter may be repeated.  
NOTE 2 – Peer-to-peer interworking with an earlier version of ISUP may result in format errors and lead to the release of the call.

**4.9 Continuity (COT)**

This section has not been reproduced as this message is not implemented.

**4.10 Facility Reject (FRJ)**

This section has not been reproduced as this message is not implemented.

**4.11 Information (INF)**

This section has not been reproduced as this message is not implemented.

**4.12 Information Request (INR)**

This section has not been reproduced as this message is not implemented.

**4.13 Initial Address Message (IAM)**

4.13.1 This message is the first message sent forward when setting up any call. It is transmitted as soon as the relevant inter-exchange traffic circuit has been selected for the call.

4.13.2 The IAM contains all the information required to route the call to the destination exchange and connect the call to the called party.

4.13.3 Immediately after sending the IAM the originating exchange will through-connect the transmission path for the relevant inter-exchange circuit in the backward direction.

4.13.4 Through-connection of the transmission path in both directions will be completed at transit exchanges immediately after the IAM has been sent.

4.13.5 The format of the IAM is shown in Table 32.

**Table 32****Message Type: Initial address**

Parameter	Reference (subclause)	Type	Length (octets)
Message type	2.1	F	1
Nature of connection indicators	3.35	F	1
Forward call indicators	3.23	F	2
Calling party's category	3.11	F	1
Transmission medium requirement	3.54	F	1
Called party number (Note 2)	3.9	V	4-16
Transit network selection (national use)	3.53	O	4-?
Call reference (national use)	3.8	O	7
Calling party number (Note 2)	3.10	O	4-16
Optional forward call indicators	3.38	O	3
Redirecting number (Note 2)	3.44	O	4-12
Redirection information	3.45	O	3-4
Closed user group interlock code	3.15	O	6
Connection request	3.17	O	7-9
Original called number (Note 2)	3.39	O	4-12
User-to-user information	3.61	O	3-131
Access transport	3.3	O	3-?
User service information	3.57	O	4-13
User-to-user indicators	3.60	O	3
Generic number (Notes 1 and 2)	3.26	O	5-?
Propagation delay counter	3.42	O	4
User service information prime	3.58	O	4-13
Network specific facility (national use)	3.36	O	4-?
Generic digit (national use) (Note 1)	3.24	O	4-?
Origination ISC point code	3.40	O	4

**Table 32**

**Message Type: Initial address**

<b>Parameter</b>	<b>Reference (subclause)</b>	<b>Type</b>	<b>Length (octets)</b>
User teleservice information	3.59	O	4-5
Remote operations (national use)	3.48	O	8-?
Parameter compatibility information	3.41	O	4-?
Generic notification indicator (Note 1)	3.25	O	3
Service activation	3.49	O	3-?
Generic reference (reserved )	3.27	O	5-?
MLPP precedence	3.34	O	8
Transmission medium requirement prime	3.55	O	3
Location number (Note 2)	3.30	O	4-?
Forward GVNS	3.66	O	5-26
CCSS	3.63	O	3-?
Network management controls	3.68	O	3-?
Circuit assignment map	3.69	O	6-7
Correlation id	3.70	O	3-?
Call diversion treatment indicators	3.72	O	3-?
Called IN number (Note 2)	3.73	O	4-?
Call offering treatment indicators	3.74	O	3-?
Conference treatment indicators	3.76	O	3-?
SCF id	3.71	O	3-?
UID capability indicators	3.79	O	3-?
Echo control information	3.19	O	3
Hop counter	3.80	O	3
Collect call request	3.81	O	3
End of optional parameters	3.20	O	1

NOTE 1 – This parameter may be repeated.

NOTE 2 – Peer-to-peer interworking with an earlier version of ISUP may result in format errors and lead to the release of the call.

**4.14 Release (REL)**

4.14.1 The Release message can be used as a forward or a backward signal, to indicate that the call is being released from the preceding or succeeding exchange.

4.14.2 The Release message is initiated by one of the following:

- (1) Calling subscriber goes on hook.
- (2) Called subscriber goes on hook.
- (3) Receipt of a REL message from a preceding exchange or a succeeding exchange.

- (4) Receipt of a clear forward signal from a preceding exchange.
- (5) Receipt of a clear back signal from a succeeding exchange
- (6) Whenever the No. 7 exchange requires to release the connection.

4.14.3 After sending a REL message the speech connection is released at the exchange but the trunk circuit concerned is held in a blocked state until a Release Complete message (RLC) is received.

4.14.4 The format of the REL message is shown in Table 33.

**Table 33**

**Message Type: Release**

Parameter	Reference (subclause)	Type	Length (octets)
Message type	2.1	F	1
Cause indicators	3.12	V	3-?
Redirection information (national use)	3.45	O	3-4
Redirection number (national use) (Note)	3.46	O	5-12
Access transport	3.3	O	3-?
Signalling point code (national use)	3.50	O	4
User-to-user information	3.61	O	3-131
Automatic congestion level	3.4	O	3
Network specific facility (national use)	3.36	O	4-?
Access delivery information	3.2	O	3
Parameter compatibility information	3.41	O	4-?
User-to-user indicators	3.60	O	3
Display information	3.77	O	3-?
Remote operations (national use)	3.48	O	8-?
End of optional parameters	3.20	O	1

NOTE – Peer-to-peer interworking with an earlier version of ISUP may result in format errors and lead to the release of the call.

#### 4.15 Release Complete (RLC)

4.15.1 This message is always sent to acknowledge receipt of a Release message (REL) and advise that release action is now complete.

4.15.2 The RLC message may be sent in either the forward or backward direction depending on the origin of the REL message.

4.15.3 The format of the RLC message is shown in Table 34.

**Table 34**

**Message Type: Release complete**

Parameter	Reference (subclause)	Type	Length (octets)
Message type	2.1	F	1
Cause indicators	3.12	O	5-6
End of optional parameters	3.20	O	1

**4.16 Subsequent Address Message (SAM)**

This section has not been reproduced as this message is not implemented.

**4.17 User-to-User Information (USR)**

This section has not been reproduced as this message is not implemented.

**4.18 Delayed Release (DRS)**

This message was included in ITU-T Recommendation Q.763 (1988) and was removed in the 1997 version. It is used by Telecom but not implemented by Telecom at the POI.

**4.19 Forward Transfer (FOT)**

This section has not been reproduced as this message is not implemented.

**4.20 Suspend (SUS)**

4.20.1 This message is used to indicate a temporary cessation of communication without releasing the call. It can only be accepted during the connective phase of a call.

4.20.2 The SUS message will be sent in response to a suspend indication from the calling or called ISDN access.

4.20.3 On the receipt of a SUS message the exchange will pass a SUS message to the preceding exchange and start a 3 minute timer. At the expiry of the time out period a Release message (cause value = 111) will be generated to release the connection.

4.20.4 The SUS message will not suspend charging in Telecom's network.

4.20.5 If the party initiating the suspend condition re-answers prior to the 3 minute timer expiry a Resume message (ref. §4.21) will be sent back to stop the timers, ensuring the connection is not released.

4.20.6 The format of the SUS message is shown in Table 38.

**4.21 Resume (RES)**

4.21.1 This message is used to indicate that the connection which has been temporarily disconnected by a Suspend message (ref. § 4.20) should now be reconnected.

4.21.2 In the Telecom network the RES message may follow a DRS message (§4.18), however, this will not apply to calls to or from another network.

4.21.3 The receipt of a RES message following a SUS will ensure that the 3 minute timer is stopped to enable the connection to remain held.

4.21.4 The format of the RES message is shown in Table 38.

**Table 38**

**Message Type: Resume, Suspend**

Parameter	Reference (subclause)	Type	Length (octets)
Message type	2.1	F	1
Suspend/resume indicators	3.52	F	1
Call reference (national use)	3.8	O	7
End of optional parameters	3.20	O	1
NOTE – Parameter compatibility information parameter may be received in the future version.			

**4.22 Blocking (BLO),  
Blocking Acknowledgement (BLA),  
Continuity Check Request (CCR),  
Loop Back Acknowledge (LPA),  
Overload (OLM),  
Reset Circuit (RSC),  
Unblocking (UBL),  
Unblocking Acknowledgement (UBA),  
Unequipped CIC (UCIC)**

4.22.1 These messages are all used for maintenance purposes associated with the inter-exchange traffic circuits under the control of ISUP. They all have the same format, as shown in Table 39.

4.22.2 BLO is sent to a neighbouring exchange whenever it is necessary to block a single outgoing circuit from the distant end (e.g. following a maintenance command input). *Multiple BLO messages are used to block a group of circuits for maintenance purposes where the circuit group blocking (CGB) message is not used (see §4.24).*

4.22.3 BLA is sent in response to a BLO to confirm that the circuit has been busied as requested.

*4.22.4 CCR is not used by Telecom.*

*4.22.5 LPA is used with continuity checking which is not done by Telecom. If it is received from another network the Telecom POI exchange will respond with a Confusion message (CFN) (ref. §4.7).*

4.22.6 OLM is sent in response to an IAM by an exchange with call processor occupancy exceeding a specified maximum value; ref Q.764 §2.9.9, Temporary Trunk Block Procedure. The preceding exchange (receiving the OLM) will release or reroute the call but will hold the inter-exchange traffic circuit to the overloaded exchange busy for a period of 2 minutes before allowing it to be reused. This will reduce traffic incoming to the overloaded exchange.

4.22.7 RSC is used to reset a circuit to the idle state in the case where memory associated with a circuit becomes mutilated, including after processor restarts. RSC ensures that both ends revert immediately to the idle state.

*As soon as No.7 link alignment is completed after processor restarts in Telecom's POI exchange, RSC messages are sent (either for all ISUP circuits or only for circuits in the pre-answer state, depending on the level of restart). Circuits are returned to the idle condition on receipt of Release Complete message (RLC) which is sent in response to RSC. The exchange which underwent the restart cannot select an ISUP circuit until the reset procedure is complete (approximately 16 circuits can be reset per second). The remote exchange may use a circuit and send an IAM before it is reset. In this case the IAM is accepted and the call proceeds, whereas if the IAM collides with RSC, IAM is rejected and the RSC is acknowledged by RLC.*

4.22.8 UBL is used to release a circuit that has previously been blocked by a BLO message.

4.22.9 UBA is sent in response to a UBL message to confirm that the circuit has been released as requested.

4.22.10 UCIC is sent in response to any message received which has a CIC that is not recognised by the receiving exchange. Receipt of UCIC by a Telecom POI exchange causes the inter-exchange traffic circuit with the specified CIC to be taken out of service, and a maintenance message to be output.

**Table 39**

**Message Type:** **Blocking**  
**Blocking acknowledgement**  
**Continuity check request**  
**Loop back acknowledgement, (national use)**  
**Overload, (national use)**  
**Reset circuit**  
**Unblocking**  
**Unblocking acknowledgement**  
**Unequipped circuit identification code, (national use)**

Parameter	Reference (subclause)	Type	Length (octets)
Message type	2.1	F	1

**4.23 Call Modification Completed (CMC)**  
**Call Modification Request (CMR)**  
**Call Modification Reject (CMR)**

These messages were included in ITU-T Recommendation Q.763 (1988) and were removed in the 1997 version. They are listed here to maintain section numbering consistent with previous versions of PTC331. They are not implemented by Telecom.

**4.24 Circuit Group Blocking (CGB),**  
**Circuit Group Blocking Acknowledgement (CGBA),**  
**Circuit Group Unblocking (CGU),**  
**Circuit Group Unblocking Acknowledgement (CGUA)**

4.24.1 These messages are all used for management purposes associated with groups of inter-exchange traffic circuits under the control of ISUP.

4.24.2 They are used to block and idle specific groups of circuits from the distant end of the circuit, e.g., in the case of an inter-exchange transmission system failure it may be necessary to block up to 30 circuits. The actual circuits to be blocked/unblocked are identified in the Range and



Status parameter and the reason for blocking/unblocking is indicated in the Circuit Group Supervision Message Type Indicator parameter.

4.24.3 The CGB message is used to request the blocking of a number of outgoing circuits due to a transmission failure or a route block maintenance command at the incoming end.

4.24.4 The CGBA message is sent in response to a CGB message to confirm that the circuits have been blocked as requested.

4.24.5 The CGU message is used to request the release of circuits previously blocked by a CGB message.

4.24.6 The CGUA message is sent in response to a CGU message to confirm that the circuits have been released as requested.

4.24.7 *Although all Telecom POI exchanges with ISUP signalling capabilities will normally send, receive and respond to this group of messages, in some circumstances blocking of a group of interconnect circuits initiated by maintenance action at the Telecom POI exchange will be done by sending multiple BLO messages (see §4.22) controlling individual circuits to the other network.*

4.24.8 Use of Circuit Group Blocking messages at the POIN exchange interface is Telecom's preference. If the interconnected network cannot support Circuit Group Blocking messages Telecom may be able to configure the interface to send only individual Circuit Blocking messages.

4.24.9 All these messages have the same format as shown in Table 40.

**Table 40**

**Message Type: Circuit group blocking  
Circuit group blocking acknowledgement  
Circuit group unblocking  
Circuit group unblocking acknowledgement**

Parameter	Reference (subclause)	Type	Length (octets)
Message type	2.1	F	1
Circuit group supervision message type	3.13	F	1
Range and status	3.43	V	3-34

## 4.25 Circuit Group Reset (GRS)

4.25.1 This message, in combination with the Circuit Group Reset Acknowledgement (GRA) message (refer § 4.6 in this document) is used to reset circuits to the idle state following exchange software initialisation at one end of the inter exchange circuits.

4.25.2 The GRS message is sent when memory associated with a group of inter-exchange traffic circuits is mutilated or following a processor restart to reset the circuits at the adjacent exchange to idle.

4.25.3 If the GRS message requests the resetting of a circuit made busy by a local maintenance command the circuit will not be reset and the GRA will indicate in the status field that the circuit is still busy.

4.25.4 Use of GRS/GRA on the POI interface is Telecom's preference. If the interconnected network cannot support GRS/GRA Telecom may be able to configure the interface to send multiple RSC messages instead of GRS by special arrangement.

4.25.5 The format of the GRS message is shown in Table 41.

#### **4.26 Circuit Group Query (CQM)**

This section has not been reproduced as this message is not implemented.

#### **4.27 Facility Accepted (FAA) Facility Request (FAR)**

This section has not been reproduced as these messages are not implemented.

#### **4.28 Pass Along (PAM)**

This section has not been reproduced as this message is not implemented.

#### **4.29 User part test (UPT), User part available (UPA)**

This section has not been reproduced as this message is not implemented.

#### **4.30 Facility (FAC)**

This section has not been reproduced as this message is not implemented.

#### **4.31 Network resource management (NRM)**

This section has not been reproduced as this message is not implemented.

#### **4.32 Identification request (IDR)**

This section has not been reproduced as this message is not implemented.

#### **4.33 Identification response (IDS)**

This section has not been reproduced as this message is not implemented.

#### **4.34 Segmentation (SGM)**

This section has not been reproduced as this message is not implemented.

#### **4.35 Loop prevention (LOP)**

This section has not been reproduced as this message is not implemented.

## ANNEX A

### TABLES FOR HANDLING OF UNRECOGNIZED PARAMETER VALUES

Reference: see 2.9.5.3/Q.764.

#### Type A exchanges

Unrecognized parameter values should be handled as indicated below in Type A exchanges (Type A exchanges as described in 2.9.5.2/Q.764). See also item iii) of 2.9.5.3/Q.764.

#### Required actions:

- Default – Handle as if the default value was received.
- Ignore – The value is "don't care"; the received value may be passed on unchanged or reset to zero.
- No default – Pass to call control.

Table A.1 shows the reaction of a Type A exchange.

Table A.1 shows the normal actions unless specific procedural text in Recommendations Q.764 and Q.73x-Series states otherwise.

**Table A.1 (sheet 1 of 4) – Type A exchanges**

Reference (subclause)	Title	Action
3.4	<i>Automatic congestion level</i>	Discard parameter
3.5	<i>Backward call indicators</i> Bits BA: Charge ind. Bits DC: Called party status ind. Bits FE: Called party category ind. Bits HG: End-to-end method ind. Bit J: End-to-end information ind. (national use) Bit L: Holding ind. (national use) Bits PO: SCCP method ind.	Default: 10 "charge" Default: 00 "no indication" Default: 00 "no indication" Default: 00 "no end-to-end method available" Default: 0 "no end-to-end info available" Default: 0 "holding not requested" Default: 00 "no indication"

**Table A.1 (sheet 2 of 4) – Type A exchanges**

<b>Reference (subclause)</b>	<b>Title</b>	<b>Action</b>
3.9	<i>Called party number</i> Nature of address ind. Numbering plan ind. Spare Address signals Filler	Send release with cause 28 Send release with cause 28 Ignore Send release with cause 28 (Note) Default: 0000
3.10	<i>Calling party number</i> Nature of address ind. Number incomplete ind. Numbering plan ind. Presentation restricted ind. Screening ind. Address signals Filler	Discard parameter Discard parameter Discard parameter Default: 01 "presentation restricted" Discard parameter No default Default: 0000
3.11	<i>Calling party's category</i>	Default: 0000 1010 "ordinary subscriber"
3.12	<i>Cause indicators</i> Coding standard Spare Location Cause value	Default: 00 "ITU-T" Ignore International: Default "international network." National: Default Beyond an Interwork. Point" Default: "Unspecified within class xxx"
3.13	<i>Circuit group supervision message type indicator</i> Bits BA: Type ind. Bits H-C: Reserved	Discard message and send confusion with cause 110 Ignore
3.14	<i>Circuit state indicators</i> Maintenance blocking state Spare	Discard message Ignore
3.16	<i>Connected number</i> Nature of address ind. Spare Numbering plan ind. Presentation restricted ind. Screening ind. Address signals Filler	Discard parameter Ignore Discard parameter Default: 01 "presentation restricted" Discard parameter No Default Default: 0000
3.18	<i>Continuity indicators</i> Bits H-B: Reserved	Ignore

**Table A.1 (sheet 3 of 4) – Type A exchanges**

<b>Reference (subclause)</b>	<b>Title</b>	<b>Action</b>
3.21	<i>Event information</i> Bits G-A: Event ind.	Discard message
3.22	<i>Facility indicators</i>	Discard message
3.23	<i>Forward call indicators</i> Bits CB: End-to-end method ind. Bit E: End-to-end inform ind. (national use) Bits HG: ISUP preference ind. Bits KJ: SCCP method indicator Bit L: Spare Bits P-M: Reserved (national use)	Default: 00 "no end-to-end method available" Default: 0 "no end-to-end info available" Send release with cause 111 Default: 00 "no indication" Ignore Ignore
3.28	<i>Information indicators (national use)</i> Bits BA: CgPA response ind. Bit C: Holding ind. Bit D: MCID response ind. Bit E: Spare Bit F: CgPC response ind. Bit G: Charge inform. resp. ind. Bit H: Solicited inf. ind. Bits P-I: Reserved	Default: "CgPA not included" Default: "Hold not provided" Default: "MCID not provided" Ignore Default: "CgPC not included" Default: "Charge inform. not included" Default: "Solicited" Ignore
3.29	<i>Information request ind. (national use)</i> Bits P-M, L-F, C: Spare/Reserved	Ignore
3.35	<i>Nature of connection ind.</i> Bits BA: Satellite ind. Bits DC: Continuity ind. Bits H-F: Reserved	Default: 10 "two satellites in the connection" See Type B exchange Ignore
3.37	<i>Optional backward call indicators</i> Bits E-H: Reserved for national use	Ignore
3.38	<i>Optional forward call indicators</i> Bits BA: Closed user group call ind. Spare Bits G-D	Default: 00 "non-CUG call" Ignore
3.39	<i>Original called number</i> Nature of address ind. Numbering plan ind. Address present. restr. ind. Address signals Filler spare	Discard parameter Discard parameter Default: "Presentation restricted" No default Default: 0000 Ignore

**Table A.1 (sheet 4 of 4) – Type A exchanges**

<b>Reference (subclause)</b>	<b>Title</b>	<b>Action</b>
3.43	<i>Range and status</i>	See Rec. 2.9.3/Q.764, 2.8.2/Q.764 and 2.8.3/Q.764
3.44	<i>Redirecting number</i> Nature of address ind. Numbering plan ind. Presentation restricted ind. Address signals Filler	Discard parameter Discard parameter Default: 01 "presentation restricted" No Default Default: 0000
3.45	<i>Redirection information</i> Bits C-A: Redirecting ind.  Bits H-E: Original redirection reason Bits K-I: Redirection counter Bits P-N: Redirecting reason Bits L, D: Spare/Reserved	Default: "Call diversion, all redirection information presentation restricted" Default: "unknown (not available)" Default: "101" Default: "unknown/not available" Ignore
3.46	<i>Redirection number</i> Nature of address indicator Numbering plan indicator Address signals Filler	discard parameter discard parameter no default default: 0000
3.51	<i>Subsequent number</i> Bits 1-7: Spare Address signal Filler	Ignore Send release with cause 28 (Note) Default: 0000
3.52	<i>Suspend/resume indicators</i> Bits H-B: Reserved	Ignore
3.53	<i>Transit network selection</i> Type of network identification Network identification plan	Release with cause 91 Release with cause 91
3.54	<i>Transmission medium requirement</i>	Send release with cause 65
3.57	<i>User service information</i>	No default
3.60	User-to-user indicators Bits CB: Service 1 Bits ED: Service 2 Bits GF: Service 3	Default: 00 "no information" Default: 00 "no information" Default: 00 "no information"
NOTE – Evaluated as far as needed for routing.		

**Type B exchanges**

Table A.2 shows the reaction of a Type B exchange.

The following definitions are used:

- Default – Handle as if the default value was received; the default value is sent.  
 Ignore – The value is "don't care", the received value may be passed on unchanged or reset to zero.  
 No default – Value received passed on unchanged.

Table A.2 shows the normal actions unless specific procedural text in Recommendations Q.764 and Q.73x-Series state otherwise.

**Table A.2 (sheet 1 of 4) – Type B exchanges**

Reference (subclause)	Title	Action
3.4	<i>Automatic congestion level</i>	Discard parameter
3.5	<i>Backward call indicator</i> Bits BA: Charge ind. Bits DC: Called party status ind. Bits FE: Called party category ind. Bits HG: End-to-end method ind. Bit J: End-to-end information ind. (national use) Bit L: Holding ind. (national use) Bits PO: SCCP method ind.	No default No default No default No default No default Ignore (international transit) No default (national transit) No default
3.9	<i>Called party number</i> Nature of address ind. Numbering plan ind. Spare Address signals Filler	Send release with cause 28 Send release with cause 28 Ignore Send release with cause 28 (Note) Default: 0000
3.10	<i>Calling party number</i> Nature of address ind. Number incomplete ind. Numbering plan ind. Presentation restric. ind. Screening ind. Address signals Filler	No default No default No default No default No default No default Ignore
3.11	<i>Calling party's category</i>	No default

**Table A.2 (sheet 2 of 4) – Type B exchanges**

<b>Reference (subclause)</b>	<b>Title</b>	<b>Action</b>
3.12	<i>Cause indicators</i> Coding standard Spare Location Cause value	No default Ignore No default No default
3.13	<i>Circuit group supervision message type indicator</i> Bits BA: Type ind. Bits H-C: Reserved	Discard message and send confusion with cause 110 Ignore
3.14	<i>Circuit state indicators</i> Maintenance blocking state Spare	Discard message Ignore
3.16	<i>Connected number</i> Nature of address ind. Spare Numbering plan ind. Presentation restric. ind. Screening indicator Address signals Filler	No default Ignore No default No default No default No default Ignore
3.18	<i>Continuity indicators</i> Bits H-B: Spare	Ignore
3.21	<i>Event information</i> Bits G-A: Event ind.	No default
3.22	<i>Facility indicators</i>	Discard message
3.23	<i>Forward call indicators</i> Bits CB: End-to-end method ind. Bit E: End-to-end information ind. (national use) Bits HG: ISUP preference ind. Bits KJ: SCCP method ind. Bit L: Spare Bits P-M: Spare (national use)	No default No default Send release with cause 111 No default Ignore Ignore



**Table A.2 (sheet 3 of 4) – Type B exchanges**

<b>Reference (subclause)</b>	<b>Title</b>	<b>Action</b>
3.28	<i>Information indicators (national use)</i> Bits BA: Calling party address resp. ind. Bit C: Hold provided ind. Bit F: Calling party's category resp. ind. Bit G: Charge inform. resp. ind. Bit H: Solicited inform. ind. Bits L-I, E, D: Spare	No default No default No default No default Default: 0 "solicited" Ignore
3.29	<i>Inform. request indicators (national use)</i> Bits P-M, L-F, C: Spare/reserved	Ignore
3.35	<i>Nature of connection indicators</i> Bits BA: Satellite ind. Bits DC: Continuity ind. Bits H-F: Spare	Default: 10 "two satellites in the connection" Default: 00 "continuity check not required" unless required on the outgoing circuit Ignore
3.37	<i>Optional backward call indicators</i> Bits H-E: Reserved (national use)	Ignore
3.38	<i>Optional forward call indicators</i> Bits BA: Closed user group call ind. Bits O-G: Spare	No default Ignore
3.39	<i>Original called number</i> Nature of address indicator Numbering plan indicator Presentation restric. indicator Address signals Filler Spare	No default No default No default No default Ignore Ignore
3.43	<i>Range and status</i>	See 2.9.3/Q.764 and 2.8.2/Q.764
3.44	<i>Redirecting number</i> Nature of address ind. Numbering plan ind. Presentation restricted ind. Address signals Filler	No default No default No default No default Ignore

**Table A.2 (sheet 4 of 4) – Type B exchanges**

<b>Reference (subclause)</b>	<b>Title</b>	<b>Action</b>
3.45	<i>Redirection information</i> Bits C-A: Redirecting indicator Bits H-E: Original redirection reason Bits K-I: Redirection counter Bits P-N: Redirecting reason Bits L, D: Spare	No default No default No default No default Ignore
3.46	<i>Redirection number</i> Nature of address indicator Numbering plan indicator Address signals Filler	No default No default No default Ignore
3.51	<i>Subsequent number</i> Bits 1-7: Spare Address signal Filler	Ignore Send release with cause 28 (Note) Default: 0000
3.52	<i>Suspend/resume indicators</i> Bits H-B: Spare	Ignore
3.53	<i>Transit network selection</i> Type of network identification Network identification plan	Release with cause 91 Release with cause 91
3.54	<i>Transmission medium requirement</i>	Send release with cause 65
3.57	<i>User service information</i>	No default
3.60	<i>User-to-user indicators</i> Bit A: Type Bits CB: Service 1 Bits ED: Service 2 Bits GF: Service 3	Default: 00 "no information" Default: 00 "no information" Default: 00 "no information"
NOTE – Evaluated as far as needed for routing.		

**ANNEX B  
GENERAL DESCRIPTION OF COMPONENT ENCODING RULES**

This annex is not reproduced as the Remote operations parameter is not implemented.

## APPENDIX 1 CIRCUIT IDENTIFICATION CODE (CIC) NUMBERING

Relationship between ISUP Circuit Identification Code (CIC) and the channel-timeslot number in the inter-exchange transmission system.

	Sys 1	Sys 2	Sys 3	Sys 4	Sys 5	Sys 6	Sys 7	Sys 8	Sys 9	Sys 10	Sys 11	Sys 12	Sys 13	Sys 14	Sys 15
Channel 0	0	32	64	96	128	160	192	224	256	288	320	352	384	416	448
Channel 1	1	33	65	97	129	161	193	225	257	289	321	353	385	417	449
Channel 2	2	34	66	98	130	162	194	226	258	290	322	354	386	418	450
Channel 3	3	35	67	99	131	163	195	227	259	291	323	355	387	419	451
Channel 4	4	36	68	100	132	164	196	228	260	292	324	356	388	420	452
Channel 5	5	37	69	101	133	165	197	229	261	293	325	357	389	421	453
Channel 6	6	38	70	102	134	166	198	230	262	294	326	358	390	422	454
Channel 7	7	39	71	103	135	167	199	231	263	295	327	359	391	423	455
Channel 8	8	40	72	104	136	168	200	232	264	296	328	360	392	424	456
Channel 9	9	41	73	105	137	169	201	233	265	297	329	361	393	425	457
Channel 10	10	42	74	106	138	170	202	234	266	298	330	362	394	426	458
Channel 11	11	43	75	107	139	171	203	235	267	299	331	363	395	427	459
Channel 12	12	44	76	108	140	172	204	236	268	300	332	364	396	428	460
Channel 13	13	45	77	109	141	173	205	237	269	301	333	365	397	429	461
Channel 14	14	46	78	110	142	174	206	238	270	302	334	366	398	430	462
Channel 15	15	47	79	111	143	175	207	239	271	303	335	367	399	431	463
Channel 16	16	48	80	112	144	176	208	240	272	304	336	368	400	432	464
Channel 17	17	49	81	113	145	177	209	241	273	305	337	369	401	433	465
Channel 18	18	50	82	114	146	178	210	242	274	306	338	370	402	434	466
Channel 19	19	51	83	115	147	179	211	243	275	307	339	371	403	435	467
Channel 20	20	52	84	116	148	180	212	244	276	308	340	372	404	436	468
Channel 21	21	53	85	117	149	181	213	245	277	309	341	373	405	437	469
Channel 22	22	54	86	118	150	182	214	246	278	310	342	374	406	438	470
Channel 23	23	55	87	119	151	183	215	247	279	311	343	375	407	439	471
Channel 24	24	56	88	120	152	184	216	248	280	312	344	376	408	440	472
Channel 25	25	57	89	121	153	185	217	249	281	313	345	377	409	441	473
Channel 26	26	58	90	122	154	186	218	250	282	314	346	378	410	442	474
Channel 27	27	59	91	123	155	187	219	251	283	315	347	379	411	443	475
Channel 28	28	60	92	124	156	188	220	252	284	316	348	380	412	444	476
Channel 29	29	61	93	125	157	189	221	253	285	317	349	381	413	445	477
Channel 30	30	62	94	126	158	190	222	254	286	318	350	382	414	446	478
Channel 31	31	63	95	127	159	191	223	255	287	319	351	383	415	447	479

	Sys 16	Sys 17	Sys 18	Sys 19	Sys 20	Sys 21	Sys 22	Sys 23	Sys 24	Sys 25	Sys 26	Sys 27	Sys 28	Sys 29	Sys 30
Channel 0	480	512	544	576	608	640	672	704	736	768	800	832	864	896	928
Channel 1	481	513	545	577	609	641	673	705	737	769	801	833	865	897	929
Channel 2	482	514	546	578	610	642	674	706	738	770	802	834	866	898	930
Channel 3	483	515	547	579	611	643	675	707	739	771	803	835	867	899	931
Channel 4	484	516	548	580	612	644	676	708	740	772	804	836	868	900	932
Channel 5	485	517	549	581	613	645	677	709	741	773	805	837	869	901	933
Channel 6	486	518	550	582	614	646	678	710	742	774	806	838	870	902	934
Channel 7	487	519	551	583	615	647	679	711	743	775	807	839	871	903	935
Channel 8	488	520	552	584	616	648	680	712	744	776	808	840	872	904	936
Channel 9	489	521	553	585	617	649	681	713	745	777	809	841	873	905	937
Channel 10	490	522	554	586	618	650	682	714	746	778	810	842	874	906	938
Channel 11	491	523	555	587	619	651	683	715	747	779	811	843	875	907	939
Channel 12	492	524	556	588	620	652	684	716	748	780	812	844	876	908	940
Channel 13	493	525	557	589	621	653	685	717	749	781	813	845	877	909	941
Channel 14	494	526	558	590	622	654	686	718	750	782	814	846	878	910	942
Channel 15	495	527	559	591	623	655	687	719	751	783	815	847	879	911	943
Channel 16	496	528	560	592	624	656	688	720	752	784	816	848	880	912	944
Channel 17	497	529	561	593	625	657	689	721	753	785	817	849	881	913	945
Channel 18	498	530	562	594	626	658	690	722	754	786	818	850	882	914	946
Channel 19	499	531	563	595	627	659	691	723	755	787	819	851	883	915	947
Channel 20	500	532	564	596	628	660	692	724	756	788	820	852	884	916	948
Channel 21	501	533	565	597	629	661	693	725	757	789	821	853	885	917	949
Channel 22	502	534	566	598	630	662	694	726	758	790	822	854	886	918	950
Channel 23	503	535	567	599	631	663	695	727	759	791	823	855	887	919	951
Channel 24	504	536	568	600	632	664	696	728	760	792	824	856	888	920	952
Channel 25	505	537	569	601	633	665	697	729	761	793	825	857	889	921	953
Channel 26	506	538	570	602	634	666	698	730	762	794	826	858	890	922	954
Channel 27	507	539	571	603	635	667	699	731	763	795	827	859	891	923	955
Channel 28	508	540	572	604	636	668	700	732	764	796	828	860	892	924	956
Channel 29	509	541	573	605	637	669	701	733	765	797	829	861	893	925	957
Channel 30	510	542	574	606	638	670	702	734	766	798	830	862	894	926	958
Channel 31	511	543	575	607	639	671	703	735	767	799	831	863	895	927	959

Relationship between ISUP Circuit Identification Code (CIC) and the channel-timeslot number in the inter-exchange transmission system.

	Sys 31	Sys 32	Sys 33	Sys 34	Sys 35	Sys 36	Sys 37	Sys 38	Sys 39	Sys 40	Sys 41	Sys 42	Sys 43	Sys 44	Sys 45
Channel 0	960	992	1024	1056	1088	1120	1152	1184	1216	1248	1280	1312	1344	1376	1408
Channel 1	961	993	1025	1057	1089	1121	1153	1185	1217	1249	1281	1313	1345	1377	1409
Channel 2	962	994	1026	1058	1090	1122	1154	1186	1218	1250	1282	1314	1346	1378	1410
Channel 3	963	995	1027	1059	1091	1123	1155	1187	1219	1251	1283	1315	1347	1379	1411
Channel 4	964	996	1028	1060	1092	1124	1156	1188	1220	1252	1284	1316	1348	1380	1412
Channel 5	965	997	1029	1061	1093	1125	1157	1189	1221	1253	1285	1317	1349	1381	1413
Channel 6	966	998	1030	1062	1094	1126	1158	1190	1222	1254	1286	1318	1350	1382	1414
Channel 7	967	999	1031	1063	1095	1127	1159	1191	1223	1255	1287	1319	1351	1383	1415
Channel 8	968	1000	1032	1064	1096	1128	1160	1192	1224	1256	1288	1320	1352	1384	1416
Channel 9	969	1001	1033	1065	1097	1129	1161	1193	1225	1257	1289	1321	1353	1385	1417
Channel 10	970	1002	1034	1066	1098	1130	1162	1194	1226	1258	1290	1322	1354	1386	1418
Channel 11	971	1003	1035	1067	1099	1131	1163	1195	1227	1259	1291	1323	1355	1387	1419
Channel 12	972	1004	1036	1068	1100	1132	1164	1196	1228	1260	1292	1324	1356	1388	1420
Channel 13	973	1005	1037	1069	1101	1133	1165	1197	1229	1261	1293	1325	1357	1389	1421
Channel 14	974	1006	1038	1070	1102	1134	1166	1198	1230	1262	1294	1326	1358	1390	1422
Channel 15	975	1007	1039	1071	1103	1135	1167	1199	1231	1263	1295	1327	1359	1391	1423
Channel 16	976	1008	1040	1072	1104	1136	1168	1200	1232	1264	1296	1328	1360	1392	1424
Channel 17	977	1009	1041	1073	1105	1137	1169	1201	1233	1265	1297	1329	1361	1393	1425
Channel 18	978	1010	1042	1074	1106	1138	1170	1202	1234	1266	1298	1330	1362	1394	1426
Channel 19	979	1011	1043	1075	1107	1139	1171	1203	1235	1267	1299	1331	1363	1395	1427
Channel 20	980	1012	1044	1076	1108	1140	1172	1204	1236	1268	1300	1332	1364	1396	1428
Channel 21	981	1013	1045	1077	1109	1141	1173	1205	1237	1269	1301	1333	1365	1397	1429
Channel 22	982	1014	1046	1078	1110	1142	1174	1206	1238	1270	1302	1334	1366	1398	1430
Channel 23	983	1015	1047	1079	1111	1143	1175	1207	1239	1271	1303	1335	1367	1399	1431
Channel 24	984	1016	1048	1080	1112	1144	1176	1208	1240	1272	1304	1336	1368	1400	1432
Channel 25	985	1017	1049	1081	1113	1145	1177	1209	1241	1273	1305	1337	1369	1401	1433
Channel 26	986	1018	1050	1082	1114	1146	1178	1210	1242	1274	1306	1338	1370	1402	1434
Channel 27	987	1019	1051	1083	1115	1147	1179	1211	1243	1275	1307	1339	1371	1403	1435
Channel 28	988	1020	1052	1084	1116	1148	1180	1212	1244	1276	1308	1340	1372	1404	1436
Channel 29	989	1021	1053	1085	1117	1149	1181	1213	1245	1277	1309	1341	1373	1405	1437
Channel 30	990	1022	1054	1086	1118	1150	1182	1214	1246	1278	1310	1342	1374	1406	1438
Channel 31	991	1023	1055	1087	1119	1151	1183	1215	1247	1279	1311	1343	1375	1407	1439

	Sys 46	Sys 47	Sys 48	Sys 49	Sys 50	Sys 51	Sys 52	Sys 53	Sys 54	Sys 55	Sys 56	Sys 57	Sys 58	Sys 59	Sys 60
Channel 0	1440	1472	1504	1536	1568	1600	1632	1664	1696	1728	1760	1792	1824	1856	1888
Channel 1	1441	1473	1505	1537	1569	1601	1633	1665	1697	1729	1761	1793	1825	1857	1889
Channel 2	1442	1474	1506	1538	1570	1602	1634	1666	1698	1730	1762	1794	1826	1858	1890
Channel 3	1443	1475	1507	1539	1571	1603	1635	1667	1699	1731	1763	1795	1827	1859	1891
Channel 4	1444	1476	1508	1540	1572	1604	1636	1668	1700	1732	1764	1796	1828	1860	1892
Channel 5	1445	1477	1509	1541	1573	1605	1637	1669	1701	1733	1765	1797	1829	1861	1893
Channel 6	1446	1478	1510	1542	1574	1606	1638	1670	1702	1734	1766	1798	1830	1862	1894
Channel 7	1447	1479	1511	1543	1575	1607	1639	1671	1703	1735	1767	1799	1831	1863	1895
Channel 8	1448	1480	1512	1544	1576	1608	1640	1672	1704	1736	1768	1800	1832	1864	1896
Channel 9	1449	1481	1513	1545	1577	1609	1641	1673	1705	1737	1769	1801	1833	1865	1897
Channel 10	1450	1482	1514	1546	1578	1610	1642	1674	1706	1738	1770	1802	1834	1866	1898
Channel 11	1451	1483	1515	1547	1579	1611	1643	1675	1707	1739	1771	1803	1835	1867	1899
Channel 12	1452	1484	1516	1548	1580	1612	1644	1676	1708	1740	1772	1804	1836	1868	1900
Channel 13	1453	1485	1517	1549	1581	1613	1645	1677	1709	1741	1773	1805	1837	1869	1901
Channel 14	1454	1486	1518	1550	1582	1614	1646	1678	1710	1742	1774	1806	1838	1870	1902
Channel 15	1455	1487	1519	1551	1583	1615	1647	1679	1711	1743	1775	1807	1839	1871	1903
Channel 16	1456	1488	1520	1552	1584	1616	1648	1680	1712	1744	1776	1808	1840	1872	1904
Channel 17	1457	1489	1521	1553	1585	1617	1649	1681	1713	1745	1777	1809	1841	1873	1905
Channel 18	1458	1490	1522	1554	1586	1618	1650	1682	1714	1746	1778	1810	1842	1874	1906
Channel 19	1459	1491	1523	1555	1587	1619	1651	1683	1715	1747	1779	1811	1843	1875	1907
Channel 20	1460	1492	1524	1556	1588	1620	1652	1684	1716	1748	1780	1812	1844	1876	1908
Channel 21	1461	1493	1525	1557	1589	1621	1653	1685	1717	1749	1781	1813	1845	1877	1909
Channel 22	1462	1494	1526	1558	1590	1622	1654	1686	1718	1750	1782	1814	1846	1878	1910
Channel 23	1463	1495	1527	1559	1591	1623	1655	1687	1719	1751	1783	1815	1847	1879	1911
Channel 24	1464	1496	1528	1560	1592	1624	1656	1688	1720	1752	1784	1816	1848	1880	1912
Channel 25	1465	1497	1529	1561	1593	1625	1657	1689	1721	1753	1785	1817	1849	1881	1913
Channel 26	1466	1498	1530	1562	1594	1626	1658	1690	1722	1754	1786	1818	1850	1882	1914
Channel 27	1467	1499	1531	1563	1595	1627	1659	1691	1723	1755	1787	1819	1851	1883	1915
Channel 28	1468	1500	1532	1564	1596	1628	1660	1692	1724	1756	1788	1820	1852	1884	1916
Channel 29	1469	1501	1533	1565	1597	1629	1661	1693	1725	1757	1789	1821	1853	1885	1917
Channel 30	1470	1502	1534	1566	1598	1630	1662	1694	1726	1758	1790	1822	1854	1886	1918
Channel 31	1471	1503	1535	1567	1599	1631	1663	1695	1727	1759	1791	1823	1855	1887	1919

Relationship between ISUP Circuit Identification Code (CIC) and the channel-timeslot number in the inter-exchange transmission system.

	Sys 61	Sys 62	Sys 63	Sys 64	Sys 65	Sys 66	Sys 67	Sys 68	Sys 69	Sys 70	Sys 71	Sys 72	Sys 73	Sys 74	Sys 75
Channel 0	1920	1952	1984	2016	2048	2080	2112	2144	2176	2208	2240	2272	2304	2336	2368
Channel 1	1921	1953	1985	2017	2049	2081	2113	2145	2177	2209	2241	2273	2305	2337	2369
Channel 2	1922	1954	1986	2018	2050	2082	2114	2146	2178	2210	2242	2274	2306	2338	2370
Channel 3	1923	1955	1987	2019	2051	2083	2115	2147	2179	2211	2243	2275	2307	2339	2371
Channel 4	1924	1956	1988	2020	2052	2084	2116	2148	2180	2212	2244	2276	2308	2340	2372
Channel 5	1925	1957	1989	2021	2053	2085	2117	2149	2181	2213	2245	2277	2309	2341	2373
Channel 6	1926	1958	1990	2022	2054	2086	2118	2150	2182	2214	2246	2278	2310	2342	2374
Channel 7	1927	1959	1991	2023	2055	2087	2119	2151	2183	2215	2247	2279	2311	2343	2375
Channel 8	1928	1960	1992	2024	2056	2088	2120	2152	2184	2216	2248	2280	2312	2344	2376
Channel 9	1929	1961	1993	2025	2057	2089	2121	2153	2185	2217	2249	2281	2313	2345	2377
Channel 10	1930	1962	1994	2026	2058	2090	2122	2154	2186	2218	2250	2282	2314	2346	2378
Channel 11	1931	1963	1995	2027	2059	2091	2123	2155	2187	2219	2251	2283	2315	2347	2379
Channel 12	1932	1964	1996	2028	2060	2092	2124	2156	2188	2220	2252	2284	2316	2348	2380
Channel 13	1933	1965	1997	2029	2061	2093	2125	2157	2189	2221	2253	2285	2317	2349	2381
Channel 14	1934	1966	1998	2030	2062	2094	2126	2158	2190	2222	2254	2286	2318	2350	2382
Channel 15	1935	1967	1999	2031	2063	2095	2127	2159	2191	2223	2255	2287	2319	2351	2383
Channel 16	1936	1968	2000	2032	2064	2096	2128	2160	2192	2224	2256	2288	2320	2352	2384
Channel 17	1937	1969	2001	2033	2065	2097	2129	2161	2193	2225	2257	2289	2321	2353	2385
Channel 18	1938	1970	2002	2034	2066	2098	2130	2162	2194	2226	2258	2290	2322	2354	2386
Channel 19	1939	1971	2003	2035	2067	2099	2131	2163	2195	2227	2259	2291	2323	2355	2387
Channel 20	1940	1972	2004	2036	2068	2100	2132	2164	2196	2228	2260	2292	2324	2356	2388
Channel 21	1941	1973	2005	2037	2069	2101	2133	2165	2197	2229	2261	2293	2325	2357	2389
Channel 22	1942	1974	2006	2038	2070	2102	2134	2166	2198	2230	2262	2294	2326	2358	2390
Channel 23	1943	1975	2007	2039	2071	2103	2135	2167	2199	2231	2263	2295	2327	2359	2391
Channel 24	1944	1976	2008	2040	2072	2104	2136	2168	2200	2232	2264	2296	2328	2360	2392
Channel 25	1945	1977	2009	2041	2073	2105	2137	2169	2201	2233	2265	2297	2329	2361	2393
Channel 26	1946	1978	2010	2042	2074	2106	2138	2170	2202	2234	2266	2298	2330	2362	2394
Channel 27	1947	1979	2011	2043	2075	2107	2139	2171	2203	2235	2267	2299	2331	2363	2395
Channel 28	1948	1980	2012	2044	2076	2108	2140	2172	2204	2236	2268	2300	2332	2364	2396
Channel 29	1949	1981	2013	2045	2077	2109	2141	2173	2205	2237	2269	2301	2333	2365	2397
Channel 30	1950	1982	2014	2046	2078	2110	2142	2174	2206	2238	2270	2302	2334	2366	2398
Channel 31	1951	1983	2015	2047	2079	2111	2143	2175	2207	2239	2271	2303	2335	2367	2399

	Sys 76	Sys 77	Sys 78	Sys 79	Sys 80	Sys 81	Sys 82	Sys 83	Sys 84	Sys 85	Sys 86	Sys 87	Sys 88	Sys 89	Sys 90
Channel 0	2400	2432	2464	2496	2528	2560	2592	2624	2656	2688	2720	2752	2784	2816	2848
Channel 1	2401	2433	2465	2497	2529	2561	2593	2625	2657	2689	2721	2753	2785	2817	2849
Channel 2	2402	2434	2466	2498	2530	2562	2594	2626	2658	2690	2722	2754	2786	2818	2850
Channel 3	2403	2435	2467	2499	2531	2563	2595	2627	2659	2691	2723	2755	2787	2819	2851
Channel 4	2404	2436	2468	2500	2532	2564	2596	2628	2660	2692	2724	2756	2788	2820	2852
Channel 5	2405	2437	2469	2501	2533	2565	2597	2629	2661	2693	2725	2757	2789	2821	2853
Channel 6	2406	2438	2470	2502	2534	2566	2598	2630	2662	2694	2726	2758	2790	2822	2854
Channel 7	2407	2439	2471	2503	2535	2567	2599	2631	2663	2695	2727	2759	2791	2823	2855
Channel 8	2408	2440	2472	2504	2536	2568	2600	2632	2664	2696	2728	2760	2792	2824	2856
Channel 9	2409	2441	2473	2505	2537	2569	2601	2633	2665	2697	2729	2761	2793	2825	2857
Channel 10	2410	2442	2474	2506	2538	2570	2602	2634	2666	2698	2730	2762	2794	2826	2858
Channel 11	2411	2443	2475	2507	2539	2571	2603	2635	2667	2699	2731	2763	2795	2827	2859
Channel 12	2412	2444	2476	2508	2540	2572	2604	2636	2668	2700	2732	2764	2796	2828	2860
Channel 13	2413	2445	2477	2509	2541	2573	2605	2637	2669	2701	2733	2765	2797	2829	2861
Channel 14	2414	2446	2478	2510	2542	2574	2606	2638	2670	2702	2734	2766	2798	2830	2862
Channel 15	2415	2447	2479	2511	2543	2575	2607	2639	2671	2703	2735	2767	2799	2831	2863
Channel 16	2416	2448	2480	2512	2544	2576	2608	2640	2672	2704	2736	2768	2800	2832	2864
Channel 17	2417	2449	2481	2513	2545	2577	2609	2641	2673	2705	2737	2769	2801	2833	2865
Channel 18	2418	2450	2482	2514	2546	2578	2610	2642	2674	2706	2738	2770	2802	2834	2866
Channel 19	2419	2451	2483	2515	2547	2579	2611	2643	2675	2707	2739	2771	2803	2835	2867
Channel 20	2420	2452	2484	2516	2548	2580	2612	2644	2676	2708	2740	2772	2804	2836	2868
Channel 21	2421	2453	2485	2517	2549	2581	2613	2645	2677	2709	2741	2773	2805	2837	2869
Channel 22	2422	2454	2486	2518	2550	2582	2614	2646	2678	2710	2742	2774	2806	2838	2870
Channel 23	2423	2455	2487	2519	2551	2583	2615	2647	2679	2711	2743	2775	2807	2839	2871
Channel 24	2424	2456	2488	2520	2552	2584	2616	2648	2680	2712	2744	2776	2808	2840	2872
Channel 25	2425	2457	2489	2521	2553	2585	2617	2649	2681	2713	2745	2777	2809	2841	2873
Channel 26	2426	2458	2490	2522	2554	2586	2618	2650	2682	2714	2746	2778	2810	2842	2874
Channel 27	2427	2459	2491	2523	2555	2587	2619	2651	2683	2715	2747	2779	2811	2843	2875
Channel 28	2428	2460	2492	2524	2556	2588	2620	2652	2684	2716	2748	2780	2812	2844	2876
Channel 29	2429	2461	2493	2525	2557	2589	2621	2653	2685	2717	2749	2781	2813	2845	2877
Channel 30	2430	2462	2494	2526	2558	2590	2622	2654	2686	2718	2750	2782	2814	2846	2878
Channel 31	2431	2463	2495	2527	2559	2591	2623	2655	2687	2719	2751	2783	2815	2847	2879

Relationship between ISUP Circuit Identification Code (CIC) and the channel-timeslot number in the inter-exchange transmission system.

	Sys 91	Sys 92	Sys 93	Sys 94	Sys 95	Sys 96	Sys 97	Sys 98	Sys 99	Sys 100	Sys 101	Sys 102	Sys 103	Sys 104	Sys 105
Channel 0	2880	2912	2944	2976	3008	3040	3072	3104	3136	3168	3200	3232	3264	3296	3328
Channel 1	2881	2913	2945	2977	3009	3041	3073	3105	3137	3169	3201	3233	3265	3297	3329
Channel 2	2882	2914	2946	2978	3010	3042	3074	3106	3138	3170	3202	3234	3266	3298	3330
Channel 3	2883	2915	2947	2979	3011	3043	3075	3107	3139	3171	3203	3235	3267	3299	3331
Channel 4	2884	2916	2948	2980	3012	3044	3076	3108	3140	3172	3204	3236	3268	3300	3332
Channel 5	2885	2917	2949	2981	3013	3045	3077	3109	3141	3173	3205	3237	3269	3301	3333
Channel 6	2886	2918	2950	2982	3014	3046	3078	3110	3142	3174	3206	3238	3270	3302	3334
Channel 7	2887	2919	2951	2983	3015	3047	3079	3111	3143	3175	3207	3239	3271	3303	3335
Channel 8	2888	2920	2952	2984	3016	3048	3080	3112	3144	3176	3208	3240	3272	3304	3336
Channel 9	2889	2921	2953	2985	3017	3049	3081	3113	3145	3177	3209	3241	3273	3305	3337
Channel 10	2890	2922	2954	2986	3018	3050	3082	3114	3146	3178	3210	3242	3274	3306	3338
Channel 11	2891	2923	2955	2987	3019	3051	3083	3115	3147	3179	3211	3243	3275	3307	3339
Channel 12	2892	2924	2956	2988	3020	3052	3084	3116	3148	3180	3212	3244	3276	3308	3340
Channel 13	2893	2925	2957	2989	3021	3053	3085	3117	3149	3181	3213	3245	3277	3309	3341
Channel 14	2894	2926	2958	2990	3022	3054	3086	3118	3150	3182	3214	3246	3278	3310	3342
Channel 15	2895	2927	2959	2991	3023	3055	3087	3119	3151	3183	3215	3247	3279	3311	3343
Channel 16	2896	2928	2960	2992	3024	3056	3088	3120	3152	3184	3216	3248	3280	3312	3344
Channel 17	2897	2929	2961	2993	3025	3057	3089	3121	3153	3185	3217	3249	3281	3313	3345
Channel 18	2898	2930	2962	2994	3026	3058	3090	3122	3154	3186	3218	3250	3282	3314	3346
Channel 19	2899	2931	2963	2995	3027	3059	3091	3123	3155	3187	3219	3251	3283	3315	3347
Channel 20	2900	2932	2964	2996	3028	3060	3092	3124	3156	3188	3220	3252	3284	3316	3348
Channel 21	2901	2933	2965	2997	3029	3061	3093	3125	3157	3189	3221	3253	3285	3317	3349
Channel 22	2902	2934	2966	2998	3030	3062	3094	3126	3158	3190	3222	3254	3286	3318	3350
Channel 23	2903	2935	2967	2999	3031	3063	3095	3127	3159	3191	3223	3255	3287	3319	3351
Channel 24	2904	2936	2968	3000	3032	3064	3096	3128	3160	3192	3224	3256	3288	3320	3352
Channel 25	2905	2937	2969	3001	3033	3065	3097	3129	3161	3193	3225	3257	3289	3321	3353
Channel 26	2906	2938	2970	3002	3034	3066	3098	3130	3162	3194	3226	3258	3290	3322	3354
Channel 27	2907	2939	2971	3003	3035	3067	3099	3131	3163	3195	3227	3259	3291	3323	3355
Channel 28	2908	2940	2972	3004	3036	3068	3100	3132	3164	3196	3228	3260	3292	3324	3356
Channel 29	2909	2941	2973	3005	3037	3069	3101	3133	3165	3197	3229	3261	3293	3325	3357
Channel 30	2910	2942	2974	3006	3038	3070	3102	3134	3166	3198	3230	3262	3294	3326	3358
Channel 31	2911	2943	2975	3007	3039	3071	3103	3135	3167	3199	3231	3263	3295	3327	3359

	Sys 106	Sys 107	Sys 108	Sys 109	Sys 110	Sys 111	Sys 112	Sys 113	Sys 114	Sys 115	Sys 116	Sys 117	Sys 118	Sys 119	Sys 120
Channel 0	3360	3392	3424	3456	3488	3520	3552	3584	3616	3648	3680	3712	3744	3776	3808
Channel 1	3361	3393	3425	3457	3489	3521	3553	3585	3617	3649	3681	3713	3745	3777	3809
Channel 2	3362	3394	3426	3458	3490	3522	3554	3586	3618	3650	3682	3714	3746	3778	3810
Channel 3	3363	3395	3427	3459	3491	3523	3555	3587	3619	3651	3683	3715	3747	3779	3811
Channel 4	3364	3396	3428	3460	3492	3524	3556	3588	3620	3652	3684	3716	3748	3780	3812
Channel 5	3365	3397	3429	3461	3493	3525	3557	3589	3621	3653	3685	3717	3749	3781	3813
Channel 6	3366	3398	3430	3462	3494	3526	3558	3590	3622	3654	3686	3718	3750	3782	3814
Channel 7	3367	3399	3431	3463	3495	3527	3559	3591	3623	3655	3687	3719	3751	3783	3815
Channel 8	3368	3400	3432	3464	3496	3528	3560	3592	3624	3656	3688	3720	3752	3784	3816
Channel 9	3369	3401	3433	3465	3497	3529	3561	3593	3625	3657	3689	3721	3753	3785	3817
Channel 10	3370	3402	3434	3466	3498	3530	3562	3594	3626	3658	3690	3722	3754	3786	3818
Channel 11	3371	3403	3435	3467	3499	3531	3563	3595	3627	3659	3691	3723	3755	3787	3819
Channel 12	3372	3404	3436	3468	3500	3532	3564	3596	3628	3660	3692	3724	3756	3788	3820
Channel 13	3373	3405	3437	3469	3501	3533	3565	3597	3629	3661	3693	3725	3757	3789	3821
Channel 14	3374	3406	3438	3470	3502	3534	3566	3598	3630	3662	3694	3726	3758	3790	3822
Channel 15	3375	3407	3439	3471	3503	3535	3567	3599	3631	3663	3695	3727	3759	3791	3823
Channel 16	3376	3408	3440	3472	3504	3536	3568	3600	3632	3664	3696	3728	3760	3792	3824
Channel 17	3377	3409	3441	3473	3505	3537	3569	3601	3633	3665	3697	3729	3761	3793	3825
Channel 18	3378	3410	3442	3474	3506	3538	3570	3602	3634	3666	3698	3730	3762	3794	3826
Channel 19	3379	3411	3443	3475	3507	3539	3571	3603	3635	3667	3699	3731	3763	3795	3827
Channel 20	3380	3412	3444	3476	3508	3540	3572	3604	3636	3668	3700	3732	3764	3796	3828
Channel 21	3381	3413	3445	3477	3509	3541	3573	3605	3637	3669	3701	3733	3765	3797	3829
Channel 22	3382	3414	3446	3478	3510	3542	3574	3606	3638	3670	3702	3734	3766	3798	3830
Channel 23	3383	3415	3447	3479	3511	3543	3575	3607	3639	3671	3703	3735	3767	3799	3831
Channel 24	3384	3416	3448	3480	3512	3544	3576	3608	3640	3672	3704	3736	3768	3800	3832
Channel 25	3385	3417	3449	3481	3513	3545	3577	3609	3641	3673	3705	3737	3769	3801	3833
Channel 26	3386	3418	3450	3482	3514	3546	3578	3610	3642	3674	3706	3738	3770	3802	3834
Channel 27	3387	3419	3451	3483	3515	3547	3579	3611	3643	3675	3707	3739	3771	3803	3835
Channel 28	3388	3420	3452	3484	3516	3548	3580	3612	3644	3676	3708	3740	3772	3804	3836
Channel 29	3389	3421	3453	3485	3517	3549	3581	3613	3645	3677	3709	3741	3773	3805	3837
Channel 30	3390	3422	3454	3486	3518	3550	3582	3614	3646	3678	3710	3742	3774	3806	3838
Channel 31	3391	3423	3455	3487	3519	3551	3583	3615	3647	3679	3711	3743	3775	3807	3839

Relationship between ISUP Circuit Identification Code (CIC) and the channel-timeslot number in the inter-exchange transmission system.

	Sys 121	Sys 122	Sys 123	Sys 124	Sys 125	Sys 126	Sys 127	Sys 128	Sys 129	Sys 130	Sys 131	Sys 132	Sys 133	Sys 134	Sys 135
Channel 0	3840	3872	3904	3936	3968	4000	4032	4064	4096	4128	4160	4192	4224	4256	4288
Channel 1	3841	3873	3905	3937	3969	4001	4033	4065	4097	4129	4161	4193	4225	4257	4289
Channel 2	3842	3874	3906	3938	3970	4002	4034	4066	4098	4130	4162	4194	4226	4258	4290
Channel 3	3843	3875	3907	3939	3971	4003	4035	4067	4099	4131	4163	4195	4227	4259	4291
Channel 4	3844	3876	3908	3940	3972	4004	4036	4068	4100	4132	4164	4196	4228	4260	4292
Channel 5	3845	3877	3909	3941	3973	4005	4037	4069	4101	4133	4165	4197	4229	4261	4293
Channel 6	3846	3878	3910	3942	3974	4006	4038	4070	4102	4134	4166	4198	4230	4262	4294
Channel 7	3847	3879	3911	3943	3975	4007	4039	4071	4103	4135	4167	4199	4231	4263	4295
Channel 8	3848	3880	3912	3944	3976	4008	4040	4072	4104	4136	4168	4200	4232	4264	4296
Channel 9	3849	3881	3913	3945	3977	4009	4041	4073	4105	4137	4169	4201	4233	4265	4297
Channel 10	3850	3882	3914	3946	3978	4010	4042	4074	4106	4138	4170	4202	4234	4266	4298
Channel 11	3851	3883	3915	3947	3979	4011	4043	4075	4107	4139	4171	4203	4235	4267	4299
Channel 12	3852	3884	3916	3948	3980	4012	4044	4076	4108	4140	4172	4204	4236	4268	4300
Channel 13	3853	3885	3917	3949	3981	4013	4045	4077	4109	4141	4173	4205	4237	4269	4301
Channel 14	3854	3886	3918	3950	3982	4014	4046	4078	4110	4142	4174	4206	4238	4270	4302
Channel 15	3855	3887	3919	3951	3983	4015	4047	4079	4111	4143	4175	4207	4239	4271	4303
Channel 16	3856	3888	3920	3952	3984	4016	4048	4080	4112	4144	4176	4208	4240	4272	4304
Channel 17	3857	3889	3921	3953	3985	4017	4049	4081	4113	4145	4177	4209	4241	4273	4305
Channel 18	3858	3890	3922	3954	3986	4018	4050	4082	4114	4146	4178	4210	4242	4274	4306
Channel 19	3859	3891	3923	3955	3987	4019	4051	4083	4115	4147	4179	4211	4243	4275	4307
Channel 20	3860	3892	3924	3956	3988	4020	4052	4084	4116	4148	4180	4212	4244	4276	4308
Channel 21	3861	3893	3925	3957	3989	4021	4053	4085	4117	4149	4181	4213	4245	4277	4309
Channel 22	3862	3894	3926	3958	3990	4022	4054	4086	4118	4150	4182	4214	4246	4278	4310
Channel 23	3863	3895	3927	3959	3991	4023	4055	4087	4119	4151	4183	4215	4247	4279	4311
Channel 24	3864	3896	3928	3960	3992	4024	4056	4088	4120	4152	4184	4216	4248	4280	4312
Channel 25	3865	3897	3929	3961	3993	4025	4057	4089	4121	4153	4185	4217	4249	4281	4313
Channel 26	3866	3898	3930	3962	3994	4026	4058	4090	4122	4154	4186	4218	4250	4282	4314
Channel 27	3867	3899	3931	3963	3995	4027	4059	4091	4123	4155	4187	4219	4251	4283	4315
Channel 28	3868	3900	3932	3964	3996	4028	4060	4092	4124	4156	4188	4220	4252	4284	4316
Channel 29	3869	3901	3933	3965	3997	4029	4061	4093	4125	4157	4189	4221	4253	4285	4317
Channel 30	3870	3902	3934	3966	3998	4030	4062	4094	4126	4158	4190	4222	4254	4286	4318
Channel 31	3871	3903	3935	3967	3999	4031	4063	4095	4127	4159	4191	4223	4255	4287	4319

## APPENDIX 2 SIGNALLING INTERWORKING BACKWARD CALL INDICATORS

Examples of Mapping of ISUP Backward Call Indicators parameter (ref. §3.4) and Optional Backward Call Indicators parameter (ref. §3.24) at the Telecom POI exchange, for calls to the Telecom network. Only bits used in the Telecom network are shown.

Note that the examples here are not exhaustive. Other combinations of codings may apply, particularly in cases where calls transit the Telecom network to other national or international networks.

Example 1. Call interworks with R2MFC or DP at or beyond the Telecom POI exchange

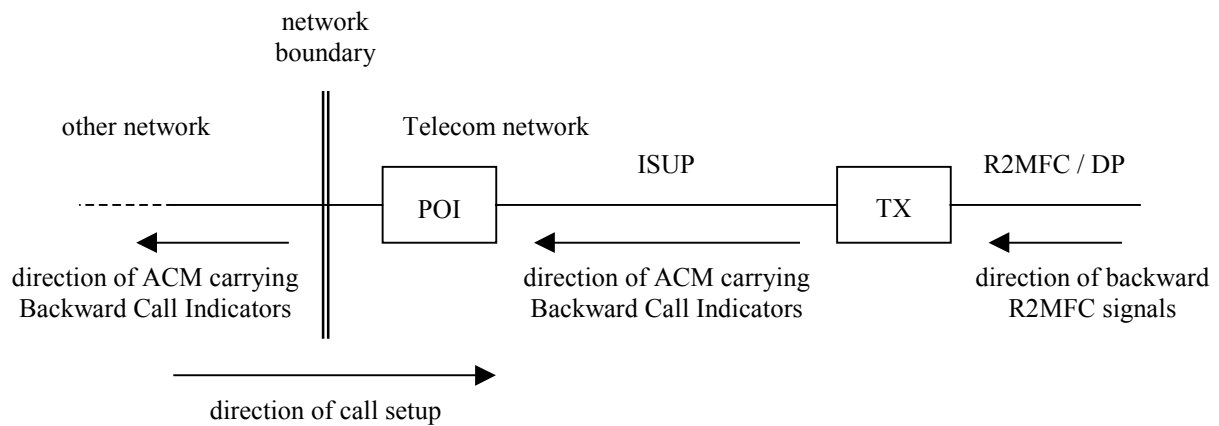

Opt. Bwd Call Ind. (bit)	Backward Call Indicator (bit)							← If applicable →	Backward Call Indicator (bit)							← If applicable →	R2MFC Backward Signal (or DP route)
HBA	M	K	I	FE	DC	BA		HBA	M	K	I	FE	DC	BA		signal	
0X1	0	0	1	01	01	10	←	1X1	0	0	1	01	01	10	←	B-1	
0X1	0	0	1	01	01	10	←	0X1	0	0	1	01	01	10	←	B-6	
0X1	0	0	1	01	01	10	←	0X1	0	0	1	11	01	10	←	B-7	
0X1	0	0	1	01	01	10	←	0X1	0	0	1	10	01	10	←	B-9	
0X1	0	0	1	01	01	10	←	1X1	0	0	1	11	01	10	←	B-10	
0X1	0	0	1	00	00	00	←	0X1	0	0	1	00	00	00	←	A6 or DP	

X = 0 or 1

X = 0 or 1



Example 2. Call terminates in the Telecom network without interworking with R2MFC or DP at or beyond the Telecom POI exchange

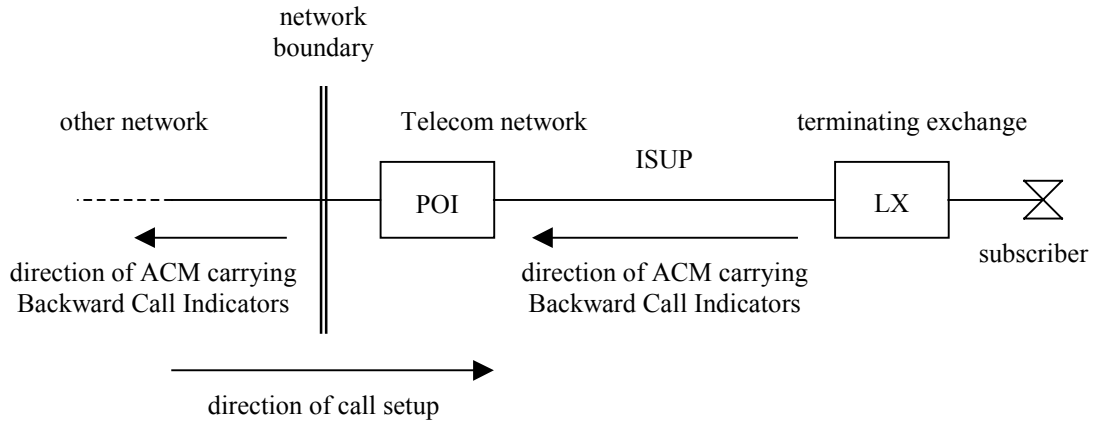

Opt. Bwd Call Ind. (bit)		Backward Call Indicator (bit)						← If applicable →		Opt. Bwd. Call Ind. (bit)		Backward Call Indicator (bit)						
HBA	M	K	I	FE	DC	BA	HBA	M	K	I	FE	DC	BA					
0XX	1	1	0	01	00	10	←	XXX	1	1	0	X1	00	10	ISDN			
0XX	0	1	0	X1	00	10	←	XXX	0	1	0	X1	00	10	PSTN (DDI)			
0X1	0	1	0	01	01	10	←	XX1	0	1	0	01	01	10	PSTN (non-DDI)			
0X1	0	1	0	01	01	10	←	XX1	0	1	0	1X	01	10				

X = 0 or 1

**APPENDIX 3**  
**RECOMMENDATION Q.764**  
**SIGNALLING PROCEDURES**

This appendix details only the exceptions and clarifications to the Common Channel Signalling System No.7 specifications adopted for Telecom network based on ITU-T Recommendation Q.764 (09/97) as applicable in the Telecom network, including the POI exchange, for purposes of interconnecting to other networks.

Where no reference is given the procedures specified in Q.764 apply.

<b>ISUP BASIC CALL PROCEDURE</b>	<b>Reference (Q.764 09/97)</b>	<b>COMMENT ON REQUIREMENTS OF NEW NETWORK NODE</b>  NOTE: The standard ITU procedures as described in Q.764 apply to all paragraphs not listed in this table
International Exchange	throughout	All references to actions specific to the international exchange (eg. §2.1.10 Forward transfer message) are not applicable to POI exchanges within the Telecom national network
Successful call setup Forward address signalling – en bloc operation Actions at originating exchange	§2.1.1.1 d)	<ul style="list-style-type: none"> <li>• Normally the standard option of completing the transmission path in the forward direction for all call types at OLE only on receipt of ANM applies.</li> <li>• In addition, Telecom will apply the specified alternative option of completing the transmission path in the forward direction for selected TMR=speech &amp; 3.1kHz audio calls at OLE when sending the IAM (for calls that require pre-answer DTMF interworking eg. for PIN entry).</li> </ul> NOTE: May later be replaced by UID procedures specified in Q.1600.
Successful call setup Forward address signalling – overlap operation	§2.1.2	Not applicable as Telecom NZ uses only en bloc operation for ISUP
Successful call setup ACM or CON message Access Delivery Indication	§2.1.4.9	Access delivery indication is not supported by Telecom NZ
Successful call setup INF messages	§2.1.6	Information messages are not supported by Telecom NZ
Successful call setup Continuity check	§2.1.8	Continuity checking is not performed within the Telecom NZ national network
Successful call setup Simple segmentation	§2.1.12	Segmentation is not used in the Telecom NZ network
Successful call setup N x 64kbit/s connection type	§2.1.13	Although supported in Telecom NZ national network exchanges N x 64kbit/s connection types are not currently used by Telecom NZ

<b>ISUP BASIC CALL PROCEDURE</b>	<b>Reference (Q.764 09/97)</b>	<b>COMMENT ON REQUIREMENTS OF NEW NETWORK NODE</b>
Unsuccessful call setup Actions at controlling exchange	§2.2.3	NOTE: The standard ITU procedures as described in Q.764 apply to all paragraphs not listed in this table  Standard. Telecom's network applies special handling for REL (CV34, 42)
Normal call release	§2.3	Note that symmetrical release procedures apply both to ISDN and PSTN originated and terminated calls (ie. on-hook by a called PSTN party causes REL to be sent)
Suspend	§2.4.1 a)	SUS (network) not supported in the Telecom network. Receipt of on-hook indication from a normal analogue (PSTN) called party at the destination node causes REL message (not SUS message) to be sent.
Resume	§2.4.2	Receipt of an off-hook indication (after on-hook) from a normal analogue (PSTN) called party at the destination node causes sending of dial tone (to enable a new call) and not RES message.
Fallback	§2.5	Fallback is not used in the Telecom NZ network
Propagation delay determination	§2.6	Propagation delay determination is not used in the Telecom NZ network
Echo control signalling procedures	§2.7	Echo control signalling procedures are not currently used in the Telecom NZ national network. Any echo control equipment is fixed for given circuits; its presence is not signalled via ISUP, nor is its activation controlled by ISUP
Network Features Abnormal blocking	§2.8.2.3 xiv)	Telecom NZ network does not support this method of remote unblocking (also ref Q.784 §1.3.2.4)
Network Features Circuit group query	§2.8.3	Circuit group query is not used in the Telecom NZ network
Abnormal conditions Dual seizure	§2.9.1	Both Selection Methods 1 and 2 are available, selectable by route data. Telecom prefers Method 2 on POI interfaces.
Temporary Trunk Block (TTB) (national use)	§2.9.9	TTB is the primary ISUP flow control mechanism used in the Telecom network and on the POI interface.

<b>ISUP BASIC CALL PROCEDURE</b>	<b>Reference (Q.764 09/97)</b>	<b>COMMENT ON REQUIREMENTS OF NEW NETWORK NODE</b>
Automatic congestion control (ACC)	§2.11	NOTE: The standard ITU procedures as described in Q.764 apply to all paragraphs not listed in this table  ACC is the secondary ISUP flow control mechanism used in the Telecom network and on the POI interface with trigger points generally set at higher levels of congestion than for initiation of TTB (§2.9.9).
ISUP availability control	§2.13.2	Inter-exchange calls in progress are not released by a signalling outage
Procedures		User part test and user part available messages are not supported
MTP Pause/Resume	§2.14	Inter-exchange calls in progress are not released by receipt of MTP pause
Overlength messages	§2.15	Standard as segmentation is not supported in the Telecom NZ network
Temporary alternative routing (TAR)	§2.16	The exchange of TAR indications in ISUP is not used in the Telecom NZ network
Hop counter procedure	§2.17	Not used by Telecom
Collect call request (CCR)	§2.18	Telecom NZ network currently operates a proprietary version of this facility (using FCI bit M=1 to mark a collect call). In future the ITU facility may be introduced.

## **APPENDIX 4 SAMPLE MESSAGE SEQUENCES**

The sample message sequences provided in issue 1 of this document have not been included.  
A paper version can be supplied on request.

## APPENDIX 5 SUPPORT OF SUPPLEMENTARY SERVICES

This appendix identifies the supplementary services, as listed in ITU-T Recommendation Q.730, supported at the POI.

ITU-T	Description	Support at the POI for interconnection
<b>Number identification supplementary services</b>		
Q.731.1	Direct-Dialling-In (DDI)	Yes (no ISUP impact)
Q.731.2	Reserved for Multiple Subscriber Number (MSN)	N/A (no ISUP impact)
Q.731.3	Calling Line Identification Presentation (CLIP)	Yes
Q.731.4	Calling Line Identification Restriction (CLIR)	Yes
Q.731.5	Connected Line Identification Presentation (COLP)	No
Q.731.6	Connected Line Identification Restriction (COLR)	No
Q.731.7	Malicious Call Identification (MCID)	No
Q.731.8	Sub-addressing (SUB)	Yes
<b>Call offering supplementary services</b>		
Q.732.1	Reserved for Call Transfer (CT)	N/A
Q.732.2	Call Forwarding Busy (CFB)	See section on Call Forwarding Procedures below
Q.732.3	Call Forwarding No Reply (CFNR)	See section on Call Forwarding Procedures below
Q.732.4	Call Forwarding Unconditional (CFU)	See section on Call Forwarding Procedures below
Q.732.5	Call Deflection (CD)	Yes
Q.732.6	Reserved for Line Hunting (LH)	N/A (no ISUP impact)
Q.732.7	Explicit Call Transfer (ECT)	Yes, but call handled as a new call using basic call control
Q.732.8	Reserved for Single Step Call Transfer (SCT)	N/A
<b>Call completion supplementary services</b>		
Q.733.1	Call Waiting (CW)	Yes but notification to calling user not sent
Q.733.2	Call Hold (HOLD)	Yes
Q.733.3	Completion of Calls to Busy Subscribers (CCBS)	No
Q.733.4	Terminal Portability (TP)	Yes

ITU-T	Description	Support at the POI for interconnection
<b>Multiparty supplementary services</b>		
Q.734.1	Conference Calling (CONF)	Yes, but call handled as a new call using basic call control
Q.734.2	Three-Party Service (3PTY)	Yes, but call handled as a new call using basic call control
<b>Community of interest supplementary services</b>		
Q.735.1	Closed User Group (CUG)	No
Q.735.2	Reserved for Private Numbering Plan (PNP)	N/A
Q.735.3	Multi-Level Precedence and Preemption (MLPP)	No
Q.735.4	Reserved	N/A
Q.735.5	Reserved	N/A
Q.735.6	Global Virtual Network Service (GVNS)	No
<b>Charging supplementary services</b>		
Q.736.1	International Telecommunication Charge Card (ITCC)	SCCP not supported at the POI Interface
Q.736.2	Reserved for Advice of Charge (AOC)	N/A
Q.736.3	Reverse Charge (REV)	No
Additional information transfer supplementary service		
Q.737.1	User-to-User Signalling (UUS)	Service 1 implicit only



**Call Forwarding (CALL DIVERSION) Procedures**

Explanation of ISUP parameters associated with multi-hop Call Forwarding using ISUP all the way. Party A calls party B; B is diverted to C; C is diverted to D; D is diverted to E; E is diverted to F.

**Standard Procedure**

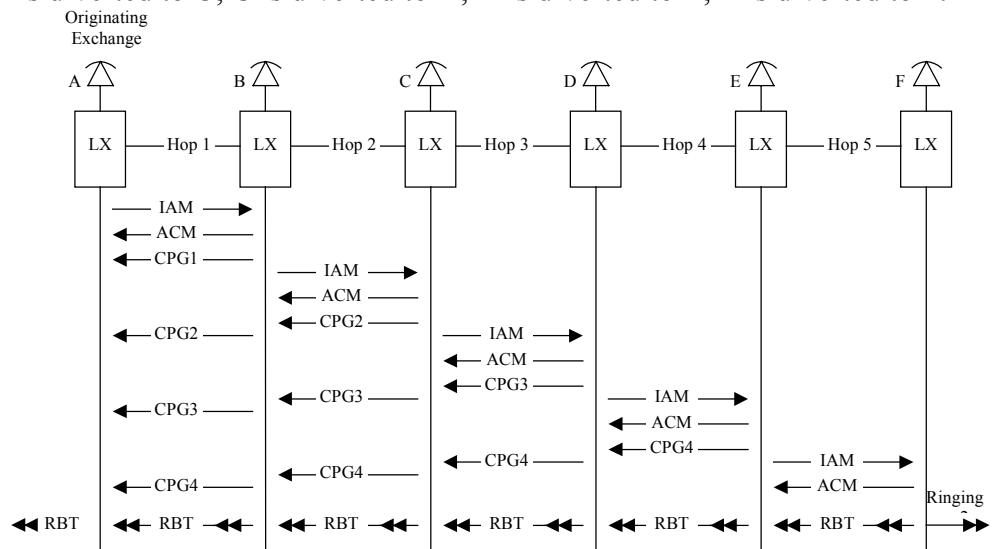

**Relevant IAM parameters**

Called Party Number	B	C	D	E	F
Calling Party Number	A	A	A	A	A
Calling Party Category	A	B	C	D	E
Redirecting Number		B (NOTE 1)	C	D	E
Original Called Number		B	B	B	B
Redirection Information:					
- Redirecting Indicator		V	V'	V''	V'''
- Original Redir. Reason NOTE 5		W	W	W	W
- Redirection Counter NOTE 3		1 (NOTE 6)	2	3	4
- Redirecting Reason		W	W'	W''	W'''

V = call forwarded  
or call forwarded all redirection info presentation restricted  
or call forwarded redirection number presentation restricted NOTE 5

W = unconditional  
or user busy  
or no reply  
or unknown/not available

**Relevant ACM parameter**

Optional Backward Call Ind	Z	Z'	Z''	Z'''	
----------------------------	---	----	-----	------	--

**Relevant CPG parameters**

	(CPG1)	(CPG2)	(CPG3)	(CPG4)	
Event Information	Y	Y'	Y''		
Redirection Number	C	D	E		

Y = Call forwarded on busy  
or Call forwarded on No Reply  
or Call forwarded Unconditionally

Z = Call forwarding may occur (only in the case that called party has call diversion on no reply service)

Note 1: Redirecting number is included at the first forwarding, in accordance with the ITU-T 03/93 and subsequent procedures.

Note 2: An alternative procedure which will occur for some forwarded calls will be for each forwarding exchange to return a CPG as the first backward message, and then for the final (non-forwarding) destination exchange to send the ACM, to the preceding exchange. The ACM will then be transited back to the originating exchange. This procedure is not included in the ITU-T 03/93 recommendations, however, it is still used in parts of the Telecom network and possibly some interconnected networks.

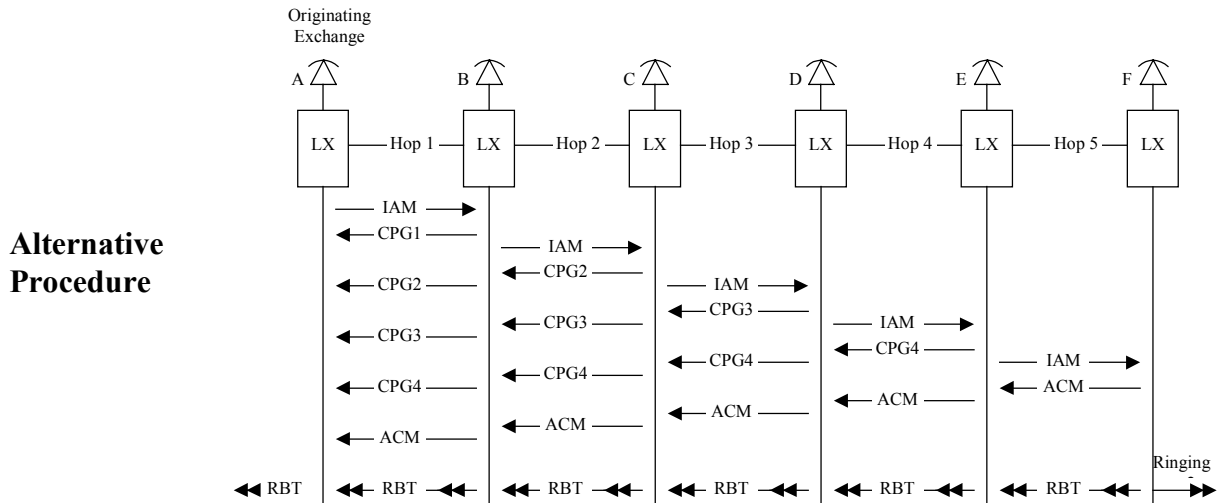

Thus for some forwarded calls, the originating exchange may receive one or more CPG messages before an ACM.

For multiple forwardings a mixture of the standard procedure and the alternative procedure may occur. The contents of parameters in the IAM will be the same as for the standard procedure.

Note 3: When the counter reaches 5 and another diverting line is reached, a Telecom exchange will release the call with:-

- cause value 17 (if diverting line has Call Forwarding on Busy)
- cause value 18 (if diverting line has Call Forwarding unconditional)
- cause value 19 (after ringing time out if diverting line has Call Forwarding on No Reply).

Note 4: ITU-T 03/93 recommendations introduced a new ISUP parameter: "redirection number restriction" sent in the backward direction for use with call forwarding services. The Telecom network does not currently support this parameter. It therefore is not to be sent on the PTC331 interface.

Note 5: ITU-T 03/93 and subsequent recommendations have marked these codings of the redirection information parameter as "national use", however, they are still set within the Telecom network and possibly in interconnected networks and may therefore be sent on the PTC331 interface.

Note 6: The 1988 recommendation option of not sending the counter with the first forwarding is not accepted by the Telecom network. The Redirection information parameter must always include the counter.

-end of PTC331-