



**Spark  
New Zealand**

## **TNA 102**

# **Characteristics of the Spark Analogue Telephone Network Customer Interface**

Access Standards

Spark Limited

Wellington

NEW ZEALAND

August 2019

**CONTENTS**

REFERENCES	2
FOREWARD	2
SPARK DISCLAIMER	3
1 SCOPE	4
2 NETWORK INTERFACE CHARACTERISTICS	5
3 DEFINITIONS	7
4 TRANSMISSION CHARACTERISTICS	12
5 SIGNALLING	20
6 D.C. LINE CONDITIONS	22
7 RINGING CHARACTERISTICS	25
8 SUPERVISORY SIGNALS	28
9 ANALOGUE ON-HOOK DATA TRANSMISSION	30
10 ANALOGUE CALLING LINE IDENTIFICATION PRESENTATION	34
11 VISUAL MESSAGE WAITING INDICATION	37
12 CUSTOMER SERVICE DELIVERY POINT PHYSICAL INTERFACE	38
13 SUMMARY OF DIFFERENCES BETWEEN INTERFACES DELIVERED BY DIFFERENT TECHNOLOGIES	39

**REFERENCES**

TNA 151 :Telecom Network Transmission Plan

PTC 107 : PABX External port interface requirements

PTC 200 : Requirements for Connection of Customer Equipment to Analogue Lines May 2006

PTC 220 : Requirements for Private Voice Networks connected to PSTN/ISDN

PTC 226 : Telecom Requirements for 2-wire 2 pin Sockets for Residential Use

TCF Premises Wiring Cable Installers Guidelines for Telecommunication Services

TCF Document: SIP ATA Standard for LFC Wholesale Service (Loose Coupling) version: 1.31 Date 26 March 2015

ITU-T Recommendation Q.552: Transmission characteristics at 2-wire analogue interfaces of digital exchanges

ITU-T Recommendation G.168: Digital Network Echo Cancellers

## **FOREWORD**

This document describes the nominal characteristics at the customer Service Delivery Point (SDP) for analogue connections to the Spark voice network.

Since the original publication of TNA 102 there have been significant changes to the network with analogue telephony now being delivered through a range of technologies in addition to a copper pair connecting directly to a NEAX digital TDM exchange.

This Specification will cover the characteristics of the different delivery mechanisms which, while being broadly the same as the original NEAX based PSTN have some significant differences.

## **SPARK DISCLAIMER**

Spark makes no representation or warranty, express or implied, with respect to the sufficiency, accuracy, or utility of any information or opinion contained in this Specification. Spark expressly advises that any use of or reliance on such information is at the risk of the person concerned.

Spark shall not be liable for any loss (including consequential loss), damage or injury incurred by any person or organization arising out of the sufficiency, accuracy, or utility of any such information or opinion.

This document describes the conditions encountered on the majority of Spark connections. It does not cover the extreme conditions that may arise on a small proportion of the total connections in the network. As an example, service in some rural areas may be provided by a combination of cable, transmission systems and/or radio systems which may not support all Spark services or terminal equipment functions.

It must be stressed that the Spark Voice network is designed for telephony. While it generally supports basic data and facsimile transmission, these functions require specific network implementations and the performance is likely to vary from place to place depending upon how service is delivered.

It must also be stressed that some of these interfaces are provided by other infrastructure providers and the parameters of the interface are can vary from one provider to another, and while Spark will endeavour to keep this document up to date, changes may occur from time to time where some interface parameters change ahead of this Specification.

## 1 SCOPE

This document describes the analogue customer interface to the Spark voice network at the Service delivery point at the customer's premises. At this interface, analogue customer equipment such as a telephone or facsimile machine meeting the requirements of PTC 200 is normally connected.

Historically, the service delivery point was simply connected back to the local telephone exchange by a cable. From the 1960s, rural customers could be served by either an analogue frequency division multiplexer or for very remote customers, a radio link (known as a country set) was used. These were relatively simple systems in that they simply monitored the electrical signals from one end and regenerated them at the other, in addition providing a two-way audio path. Signalling was relatively simple; loop disconnect for dialling outgoing calls and ringing for incoming calls, and supervisory functions simply the remote party listening to audio tones on the audio (speech) path.

These analogue systems are no longer in use, and have been replaced by new digitally based systems.

The main systems in use today are as follows:

- Direct copper cable pair connections to a Time Division Multiplex (TDM) telephone exchange (PSTN).
- Direct copper pair connection to a TDM multiplexer in a Chorus Cabinet.
- Direct copper pair connection to an IP line card in a Chorus Cabinet.
- Direct connection to an Analogue Terminal Adapter (ATA) incorporated in an Optical Network Termination (ONT) located in the customer's premises.
- Connection to an ATA incorporated in a 4G wireless terminal located in the customer's premises.
- Direct copper pair connection to a multi-access radio terminal.

In addition to these interfaces, PBXs and Private Networks with Single Line Telephone (SLT) interfaces complying with PTC 220 section 5 can be classed amongst these interfaces.

This Specification documents the customer interfaces of the above which allows customer equipment designers/manufacturers to supply equipment which can work satisfactorily with all of the interfaces. It should be noted that as the network evolves, the access technology used, and therefore the interface at the service delivery point, are likely to change as well. At this stage, the majority of customer connections are still in the first two categories which is described by the original version of TNA 102. This specification will specify each parameter, with any variations documented with the specification for that parameter. In addition, a summary of the differences from TNA 102 will be presented in Section 13 of this Specification.

## 2 NETWORK INTERFACE CHARACTERICS

The Characteristics at the Service Delivery Point (SDP) for some methods of access cannot be precisely defined for every installation as there are a range of access line parameters which vary from customer to customer. This document will define the range of conditions likely to be encountered on the majority of lines.

Figure 1 shows the functional blocks which are present in an analogue customer interface to a telephone network.

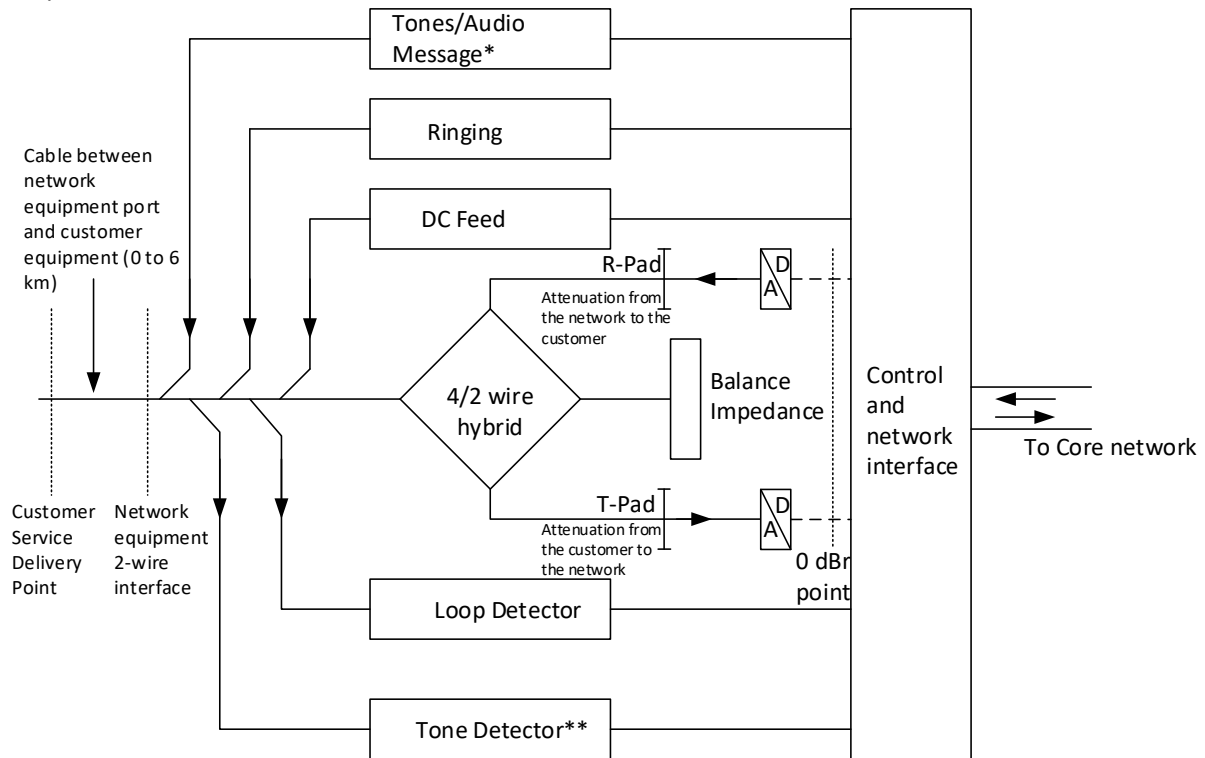

\* Tones fed to the customer interface may be carried in the audio path from elsewhere in the network or may be generated in the interface. These tones are generally used for call progress indicators (busy tone, ringing tone etc) but also include FSK Caller ID and message waiting indicators

\*\* Tone detection may be performed at the interface (typically for packet based systems) or the tones may be carried back to the core network via the speech path (typically for TDM based systems)

**Figure 2.1 Functional Block diagram of an analogue customer interface**

Points to note are:

Where the interface is remote from the core network, the connection to the core may be via copper, Fibre or Wireless, and may use TDM or packet techniques. In the case where the interface is part of the telephone exchange, the interface (Line card) is connected directly to the TDM bus within the NEAX switch.

Where there is a copper cable access line between the customer and the network interface equipment, the objective has been to engineer the network so that the traffic weighted mean loss between the customer and the interface is 2.5 dB. Where the interface equipment is located in the

customer's premises, the T and R pads in the interface are increased by 2.5 dB to compensate for having a virtually zero length access cable.

This specification is broken into 8 sections, defining in the interface as follows:

1. Transmission Characteristics of the audio path
2. Signalling from the Customer equipment to the network
3. d.c. characteristics
4. Ringing characteristics
5. Supervisory Tones
6. Analogue On-hook data transmission
7. Customer Service Delivery Point physical interface
8. Summary of differences between interfaces delivered by different technologies

### 3 DEFINITIONS

#### 3.1

In general, definitions set by the International Telecommunications Union and published in the ITU-T Recommendations apply throughout this Specification. Nevertheless, some ITU-T definitions are not particularly informative for those unfamiliar with telephone engineering and therefore the following definitions are provided. Where necessary, these are supplemented by explanatory notes which elaborate on the formal wording.

#### 3.2

Additional definitions are provided in all PTC Specifications. Nevertheless, some definitions are repeated in this document for ease of use and for explanatory purposes:-

**Analogue Terminal Adapter (ATA):** is a network to customer interface as a standalone piece of equipment which provides all the network interface functions. It is usually located in the customer's premises. It is connected to the network core by fibre, wireless or DSL over copper. Also known as an FXS (Foreign Exchange Subscriber) interface.

**Called party:** is the person or device receiving a call.

**Calling party:** is the person or device initiating a call.

**Convergence:** is a term used in connection with echo cancellation and is the process of developing a model of the echo path which will be used to estimate the circuit echo.

- *See also "echo control device".*

**Crosstalk:** is any unwanted signal introduced into a line or equipment through coupling between one or more other lines or items of equipment not electrically connected.

**dBm:** is the absolute power level in decibels (dB's) relative to 1 mW.

**dBm0:** is the absolute power level in decibels referred to a point of zero relative level (0 dBr).

**dBr:** is the nominal relative power level in decibels referred to a point of zero relative level (0 dBr).

**Decadic:** is the form of call initiation signalling which makes use of one or more timed disconnections of the line current.

- *Otherwise referred to as "loop-disconnect" signalling or "pulse" signalling. It is the form of signals sent by an ordinary rotary telephone dial. It is now largely superseded by "tone" signalling (DTMF).*
- *At present all Spark TDM exchanges are capable of responding to decadic signalling. However, as these become progressively replaced, decadic signalling will cease to be available.*

**Derived circuit:** is a circuit which is provided by means other than a physical pair of wires from the telephone exchange to the customer's premises.

- Typical examples of this are circuits over fibre optic and wireless systems.

**Direct dialling-in (DDI):** is the facility to allow incoming calls from the PSTN to be switched directly to a specified station (e.g. PABX extension) without operator assistance.

**Distinctive Alerts (DA):** are the four different ringing cadences (DA1 to DA4) which allow multiple devices connected to the same line to respond to specific cadences while ignoring others

- *Is mainly used to allow facsimile machines to share phone lines with a telephone. The Facsimile machine is set to respond to DA4 and ignore the standard telephone ring cadence DA1*

**Double talk:** relates to echo control and describes the condition whereby signals are present in both directions of a 4-wire circuit at the same time.

- *This occurs when both parties in a telephone conversation are speaking at once and the situation requires special treatment by any echo control device present in the circuit.*

**DTMF (Dual Tone Multi-Frequency):** is a signalling system used over PSTN customer lines whereby two tones are sent simultaneously to line for each digit.

- *It is used both for call initiation and for the accessing or controlling of other services, often between customers, following connection of a call.*
- *The DTMF standard is described in ITU-T Recommendation Q 23.*

**Echo:** is an unwanted signal reflection delayed to such a degree that it is perceived as distinct from the signal directly transmitted.

In telecommunication networks, there is a distinction made between "talker echo" and "listener echo" as follows:-

(a) "Talker echo" is the reflected signal experienced at the terminal sending the original signal. This is particularly disturbing to the person speaking in a telephone conversation who hears their own voice returning, but delayed enough to disrupt their flow of speech.

(b) "Listener echo" is the reflected signal experienced at the terminal receiving the original signal. This can be a problem for data transmission since the receive terminal is likely to receive the same signal twice, the second being sufficiently delayed, but of high enough power level to be interpreted as another valid signal.

**Echo control device:** is a device, operated by voice signals, which is used in telecommunication networks to reduce the effect of echo by either suppressing or cancelling the echo signal.

- *The "Echo suppressor" was the earlier form of echo control used internationally. This device reduced the effect of echo by introducing additional loss in the echo path. It is rarely used now.*
- *Later technology developments introduced the "echo canceller" which is a more effective method of controlling echo. This estimates the echo signal from an examination of the original signal and subtracts that estimated signal from the actual echo signal without affecting the transmission path.*

**External Test Point (ETP):** is the terminal box, fitted at the customer's end of a cable lead-in, in which the lead-in cable is connected to the building cabling.

- *The ETP may also be used to house a simple electrical termination which allows remote testing of the line from the exchange through to the customer's premises when no terminal equipment has been connected.*

**Full current:** is the current drawn by any item of terminal equipment when connected directly to a 50 V, 400  $\Omega$  source in the off-hook condition.

- *"Full current" is used for test purposes and defines the maximum current that can be drawn under zero line conditions.*
- *Most lines are current limited to well below the current that a 50 V, 400  $\Omega$  source would deliver. Current limits as low as 25 mA are often used.*



**Individual line:** is a line serving a single customer.

- *An individual line may have one or more devices connected within that customer premises.*

**Inter-digital pause:** is the interval between successive DTMF tone bursts in a series of digits.

**Key telephone system (KTS):** is a small telecommunications system designed for use in customer's premises which provides switching facilities between individual extension devices and the network connection.

- *Simple KTS's often have a nominal 0 dB (i.e.  $\leq 1$  dB) transmission loss between ports.*
- *See also "PABX" for further details.*
- *For the purposes of this and other TNA documents, and PTC Specifications, the term "PABX" embraces all Private Automatic Branch Exchange (PABX), Key Telephone System (KTS), Small Business Exchange (SBX) and other equipment intended for installation in a customer's premises to switch calls between separate telephone lines and extensions.*

**Line impedance:** is the terminating impedance presented to a line by any equipment to which it is connected.

**Loop current:** is the standing d.c. current drawn by any equipment in the off-hook condition.

- *The loop current is dependent upon the resistance of the equipment, the line length and any current limiting by the exchange line feed equipment.*

**Loudness Rating (LR):** is a measure, expressed in decibels, for characterising the loudness performance of complete telephone connections, or parts thereof, such as the sending system, line, or receiving system.

- *Reference ITU-T Rec. P. 64:1993, P. 65:1993, and CCITT Blue Book, Rec. P. 76.*
- *Loudness rating is an internationally accepted method of objectively measuring the performance of telephones from the mouthpiece to a given point on the line, and vice versa to the earpiece. The approach enables computer-controlled measuring equipment to be used for making quick, accurate and, above all, repeatable tests.*
- *A loudness value is the result of a calculation based on fourteen separate measurements made at pre-determined frequencies within the normal telephony frequency range, each measurement being "weighted" according to its effect as perceived by the human ear when listening to normal spoken words.*
- *The loudness measurement value is actually the loss involved in the circuit under test, relative to an internationally accepted reference standard. Thus the higher the loudness value the quieter the perceived signal volume. A negative value occurs when the loss is actually less than that of the reference standard.*
- *Overall loudness rating (OLR) is the sum of the send loudness rating (SLR) of the telephone at one end of a telephone connection, the receive loudness rating (RLR) of the telephone at the other end, and the loudness ratings of each section of line in between. In other words it is a measure of the overall electro-acoustic performance between mouthpiece at one end and earpiece at the other.*

**Master jack-point:** is a telecommunications outlet which provides the 'on-hook' line termination for a Telecom PSTN line and derives the 'shunt' wire for 3-wire connection.

- *The 3-wire system for customer premises wiring was introduced in the 1980s as a means of preventing decadic phones causing "bell tinkle" in other parallel connected phones during dialling. It is no longer used although some older installations may still have it. It is detrimental to xDSL services and should be converted to 2-wire.*

**Off-hook:** is the condition where the equipment is connected to line and is used to initiate or take part in a call.

**On-hook:** is the condition where the equipment is connected to line in the idle state awaiting receipt of an incoming call or available to initiate a call.

- *The above terms are derived from the term "hook-switch", which is used to describe any device which changes the status of the equipment from "on-hook" to "off-hook" or vice versa.*

**On-hook data transmission:** is the transmission of information in the form of data signals over a PSTN line while the terminating CPE is in the on-hook condition.

- *This data is typically used for transmitting Caller ID and message waiting information to a customer.*

**PABX (PBX):** Private Automatic Branch Exchange (Private Branch Exchange) is a form of telecommunications system designed for use in a customer's premises which provides full switching facilities between individual extension devices and the network.

- *See also "Key Telephone Systems".*
- *For the purposes of this and other TNA documents, and PTC Specifications, the term "PABX" embraces all Private Automatic Branch Exchange (PABX), Key Telephone System (KTS), Small Business Exchange (SBX) and other equipment intended for installation in a customer's premises to switch calls between separate telephone lines.*
- *For Telepermit purposes, it is necessary to divide PABX's/KTS's into two defined categories as follows:-*
  - (a) Type 1: 4-wire switching devices (digital or analogue) which, by their very nature are designed to have an inherent 2 - 3 dB transmission loss between extension and 2-wire analogue trunk ports (ref. Specification PTC 109).*
  - (b) Type 2: 2-wire analogue switching devices without networking facilities and which have a nominal 0 dB ( $\leq 1$  dB) transmission loss between extension and trunk ports.*
- *Most KTS's can be categorised as Type 2 and most large PABX's as Type 1, but this is not always the case.*
- *For the purposes of defining interface requirements a PABX system may be considered to provide a similar range of conditions to that of a public exchange line.*

**Psophometric:** is the term used to describe a method of measuring noise within the speech band while weighting the value of each frequency component present in accordance with its relative effect on the human ear.

- *Such measurements are normally made with a psophometer, which is a voltmeter fitted with a standardised frequency weighting network and calibrated to indicate noise power or voltage in psophometric units (dBmp or mV psophometric).*
- *The weighting coefficients defined in CCITT Blue Book, Rec. O. 41 for telephone circuits and weighted to a reference tone of 800 Hz are used by Telecom for telephony purposes.*

**PSTN:** is the Public Switched Telephone Network.

- *New Zealand PSTN services may be provided by a number of different Network Operators, each of which can set different network interface requirements should they choose to do so.*

**Recall:** is the procedure used to re-connect the register function of a switching system to enable additional features of that system to be used while a call is in progress.

**Ringer (or ringing detector):** is any device which responds to the alternating voltage applied to indicate an incoming call.

**Secondary jack-point:** is a telecommunications outlet which provides an additional connection point to a Telecom PSTN line which is also equipped with a Master jack-point.

- *This jack-point provides only a CPE connection facility and is wired in parallel to a Master jack-point.*

**Service Delivery Point (SDP):** is the defined electrical interface point provided at an agreed physical location to which Telecom will deliver service to a customer.

- *In commercial premises, the SDP may or may not be the same as the network demarcation point. Cable owned by a third party, such as the building owner, may be used to serve the SDP.*

**Signalling:** is the exchange of information (other than by speech) which is specifically concerned with the establishment, release and other control of calls over the PSTN.

- *The term "signal" can also be used in connection with other types of transfer of information, but only if suitably qualified, e.g. "data signal", "voice signal".*

**Telecommunications outlet (TO):** is any jack-point forming part of the fixed wiring in a customer's premises at which CPE may be connected to a telecommunications network.

- *This was typically a BT jack-point, but is being superseded by the 4 pair RJ45 socket*

**Telepermit:** is the Registered Trade Mark used to indicate Spark's agreement to the connection of equipment to its network.

**Two-wire jack-point:** is a version of the BT jack-point which superseded the Master/Secondary jack-points. This in turn was later superseded by the 2-C (two contact) jack-point which only had contacts 2 and 5 equipped to increase reliability by increasing the distance between contacts.

## 4 TRANSMISSION CHARACTERISTICS

### 4.0 General

The PSTN network has been designed for switching voice calls, although has been also used for switching voice band data calls using modems. To get the maximum perceived dynamic range a simple compression algorithm is used. In New Zealand the codecs used are ITU-T G.711 A-law codecs. Compression is matched to the human perception of sound which is approximately logarithmic, so as the level increases, the quantization steps increase in size

The networks uses two basic transmission techniques, Time Division Multiplex (TDM) and Packet based, increasingly using Internet Protocol (IP). Often an end to end Call will use a combination.

#### 4.0.1 Time Division Multiplex (TDM)

TDM was used in the first digital transmission systems, and was the dominant technology for voice networks up until the beginning of the 21<sup>st</sup> century. In a conventional TDM network, the analogue voice signal is band limited to 3100 Hz (300 – 3400 Hz), then sampled at 8000 times a second, and converted by an A-law codec into an eight bit word. This gives a digital transmission rate of 8000 Samples/second X 8 bits per sample = 64,000 bits/sec. (64 kbps). At the other end of the circuit, the 64 kbps bitstream is converted back to an analogue signal 8 bits at a time. Every second, this conversion back to analogue will happen 8000 times. Within the voice bandwidth of 3100 Hz, the analogue signal reproduced at the far end will theoretically be an exact copy of the analogue signal at the sending end. The Multiplex part of TDM is simply a method of interleaving multiple 64 kbps voice streams, for example 32 64 kbps circuits can interleaved to form one 2.048 Mbps circuit known as an E1 circuit. Likewise, multiple E1 circuits can be interleaved to form higher bit rate circuits.

#### Strengths of TDM

- An end to end circuit is inherently synchronised, so the bits are clocked out of the circuit by a clock which is synchronised to the clock clocking the bits into the sending end of the circuit. This is essential for high speed data modems to operate.
- Once the end to end call is established, the transmission resource is guaranteed for the duration of the call.
- There is little or no processing resource required once the call is established.
- Relatively low delay makes it good for real time interactive communications such as voice or video conferencing.
- Security from hacking. As the end to end data is carried separately from the call control information, and the call control information is often carried on a physically separate network which is not accessible publicly, TDM networks are relatively secure.

#### Weaknesses of TDM

- Inefficient for bursty data such as internet browsing where the full capacity of the circuit is only used occasionally.
- Inflexible. Because it has evolved specifically for the 64 kbps voice application it is difficult to adapt it for anything else such as wide bandwidth voice.

#### 4.0.2 Packet transmission especially Internet Protocol (IP)

Unlike TDM circuits which connect two end points for the full duration of a call, end to end IP communication is “connectionless”. For voice over IP telephony a packet is typically assembled from 160 x 8 bit voice samples, and the packet then sent to the destination end. Each packet contains all the information required by the network to route it to the far end. From the network perspective each packet is a self-contained event, and on a packet by packet basis, the network will attempt to find enough resource. Whether it succeeds or not depends on how busy the network is at that instant.

##### Strengths of IP

Efficient use of resource

Good for intermittent (bursty) data as resource is only used when necessary.

Good for unidirectional non-time-critical data

##### Weaknesses of IP

Not end to end synchronised. This is not generally a problem, but voice-band data modems may be unreliable as the all modems above 2400bps use phase locked loops to synchronise their internal clocks. Jitter between end points makes this process unreliable.

IP networks generally have larger end to end delays making them unsuitable for real time interactive communications such as voice and video conferencing. This is in part due to the fact that every packet has to be processed separately, and also due to an IPv4 packet header being 70 bytes long it becomes very inefficient to send short packets.

Because network control information is carried in the same packets as user information, an IP is inherently less secure. While there are means of mitigating the security issues, these generally increase the delay.

#### 4.1 Loss Plan

(1) The loss plan follows ITU-T Recommendations which specifies a Send Loudness Rating (SLR) from a telephone handset to the 0 dBr point of 8 dB and a Receive Loudness Rating (RLR) from the 0 dBr point to the handset of 2 dB. These are made up of several components shown in Figures 4.1 and 4.2.

(2) If the telephone is connected via a local access cable, the loss plan assumes that the traffic weighted average loss in the local cable is 2.5 dB, and the interface loss PADS are set at 0.5 dB (T-Pad) and 6.0 dB (R-Pad) as shown in Figure 4.1.

The parameters given are at the MDF for a Telephone exchange or at the port on a derived circuit, so the frequency response and overall loss will be modified by the characteristics of the cable between the customer equipment and the network equipment port.

(3) If the Interface is in the customer’s premises the loss between the interface and the telephone may be assumed to be close to zero, so for consistency, the 2.5 dB local cable loss is added to the T and R Pads in the customer located ATA as shown in Figure 4.2.

(4) Networks are interconnected with each other at the 0 dBr point. These interconnections are digital, so there is no loss between networks (both nationally and internationally). If private voice networks are connected to public networks digitally (ISDN or SIP trunking) they will usually extend the 0 dBr point into their own network.

(5) The maximum level at the input to the codec is +3.14 dBm. This is equivalent to 3.14 Vpp (600 Ohm). On a zero-length line for a reticulated access connection, the maximum input level will be increased by 0.5 dB so the maximum input level will be 3.64 dBm or 3.33 Vpp. When access is via a customer located ATA, then the maximum level at the port will be increased by an additional 2.5 dB. The maximum input level at the ATA port will be 6.14 dBm (4.44 Vpp).

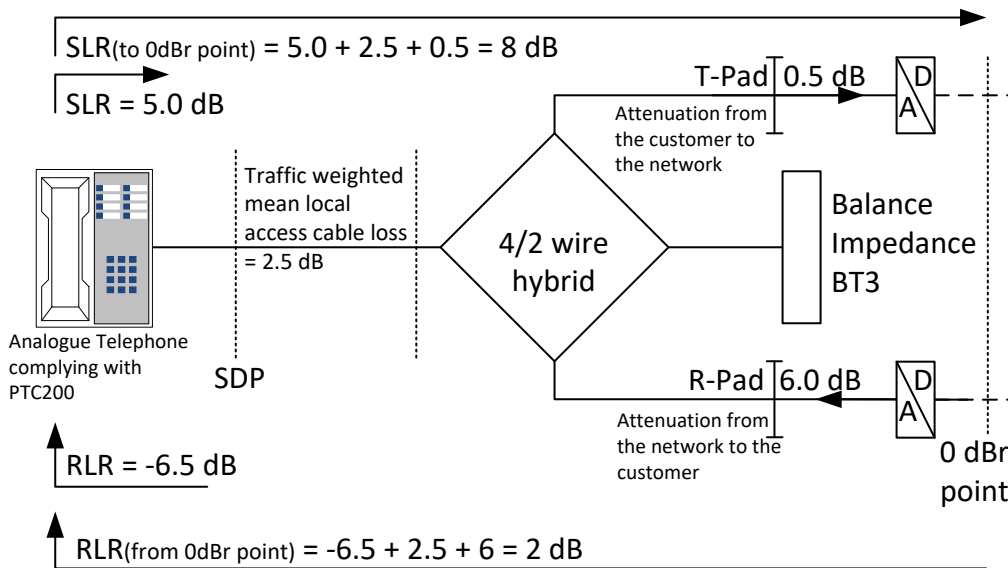

Figure 4.1 Transmission losses for connection to line card via reticulated cable

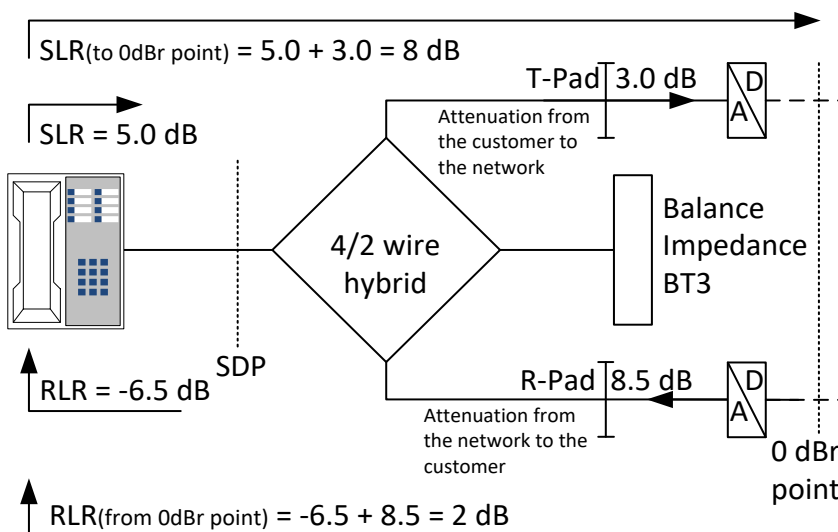
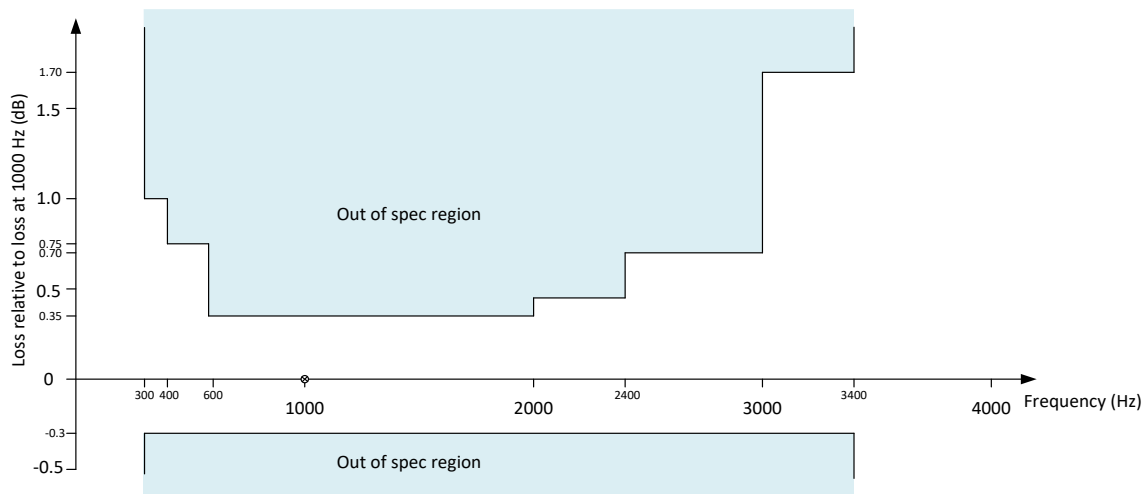

Figure 4.2 Transmission Losses for connection to customer located ATA

## 4.2 Frequency Response

The frequency response of the network is nominally 300 - 3400 Hz. The objective frequency response is shown in Figure 3.3



**Figure 4.3 Frequency response of the analogue interface**

Notes:

1. This is an objective frequency response for a signal of -10 dBm0 between the analogue 2-wire interface and the 0 dBr point in both directions.
2. The frequency response is relative to the loss at 1000 Hz.
3. The objective frequency response assumes that the input and balance impedances are both BT3.
4. In practice, the frequency response at the SDP will vary according to the length of cable between the line interface and the SDP. Generally, as the line increases in length, the high frequencies will be attenuated more than the lower frequencies.
5. The frequency response is specified by the ITU-T in Recommendation Q.552.

## 4.2 Variation of Gain with Input level

The loss/gain variation with input level is shown in Figure 4.4

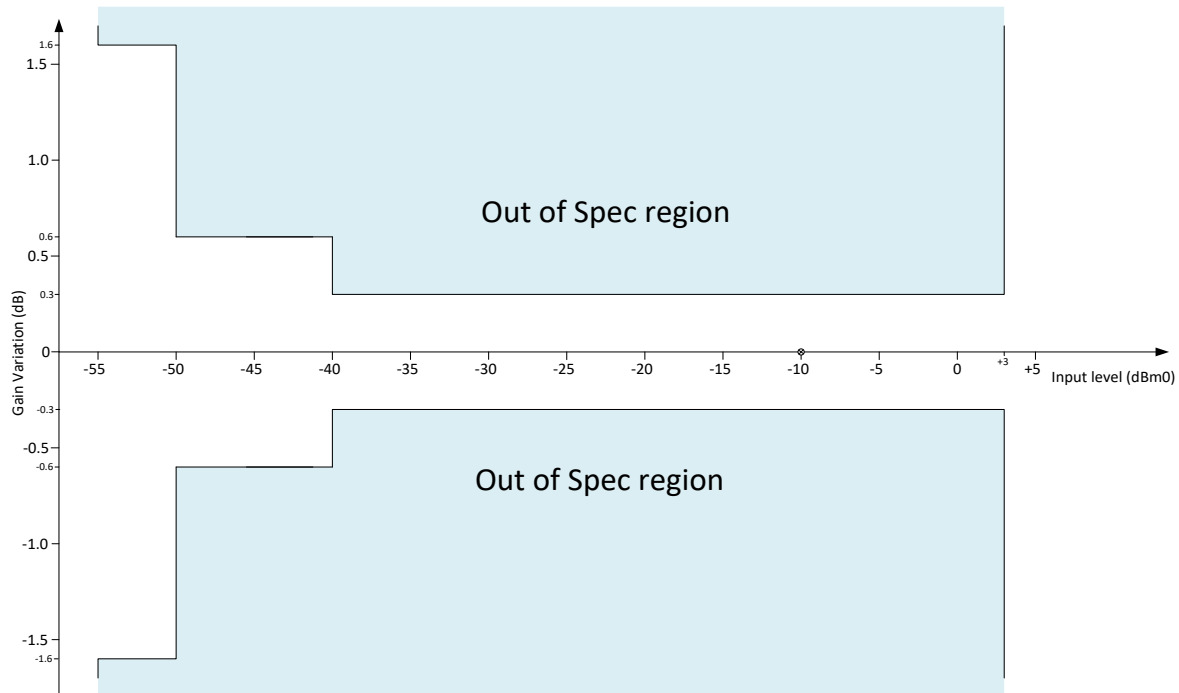

**Figure 4.4** Variation of Gain with input level

## 4.3 Impedance

### 4.3.1 Input Impedance

The impedance looking into the port is nominally BT3. This is a passive network made up of a 370 Ohm resistor in series with a parallel combination of a 620 Ohm resistor and a 310 nano-Farad Capacitor (see fig 4.5). The significance of the input impedance is that it must match the balance impedance of the customer equipment. Mismatch will increase the sidetone in the customer equipment to a point where the customer equipment can oscillate if the mismatch is bad enough. For a telephone, the sidetone is measured directly rather than the telephone balance impedance.

### 4.3.2 Network balance impedance

The network balance impedance is also BT3 (see 4.3.1 and fig. 4.5). For optimum performance, the input impedance of the customer equipment must match the Network Balance impedance. Mismatch will cause signals to circulate within the network which is heard as echo at the other end of the call. If the network connection is short enough the echo will appear to be increased sidetone. See fig. 4.6. The degree of match between Customer Equipment Input Impedance and BT3 is measured as a return loss at frequencies across the voice band (300 to 3400 Hz).



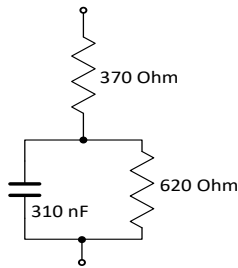

**Figure 4.5 BT3 Network**

## 4.4 Network Echo Control

### 4.4.1 Causes of echo

(1) The total control of echo by means impedance matching alone (ref. clause 4.3) is not practicable due to component tolerances and other variables. There is always a certain amount of signal reflection occurring whenever there is a 2-wire/4-wire transition. This particularly becomes a problem when signal delay is introduced in the transmission path, e.g. on long distance or international calls. This delay causes the signal reflection to become noticeable as 'talker echo' which can make telephone conversation extremely difficult. Further 'near end' reflections produce 'listener echo' which is often an additional problem for the transmission of data.

(2) The change from analogue to digital transmission around the world during the 1980s and 1990s, further compounded the problem by introducing additional processing delays into transmission paths. The later use of packet based systems further increases delay requiring extensive use of echo control measures.

### 4.4.2 Control of echo

(1) There are two types of echo control devices commonly used on circuits where echo is likely to result on PSTN calls. These are as follows:

(a) Echo suppressors: These control echo by inserting a loss of at least 30 dB in the transmission path in the direction opposite to that of the original signal. This loss is removed after a period of 100 ms of quiet time. When signals are present simultaneously in both directions for a period of 50 ms, the echo suppressors enter the "double talk" state in which 6 to 15 dB of loss is added to both directions of transmission.

- *Echo suppressors were used in the 1980s, but are no longer deployed as they are inferior in performance to echo cancellers. It is unlikely that echo suppressors will be encountered in the current network.*

(b) Echo cancellers: These control echo by adding loss to the echo signal only, without affecting the transmission path. After a training (converging) period of approximately 500 ms, the echo canceller will assure an echo loss of at least 40 dB. During the "double talk" state the degree of echo cancellation may diminish slightly, but the transmission path is again not affected. At the start of a call echo cancellers characterise the call path and measure the levels and delays of the echo signals which are then subtracted from the signal thus eliminating the echo. To further reduce the low-level echoes, a non-linear processor is used to attenuate signals below a noise threshold.

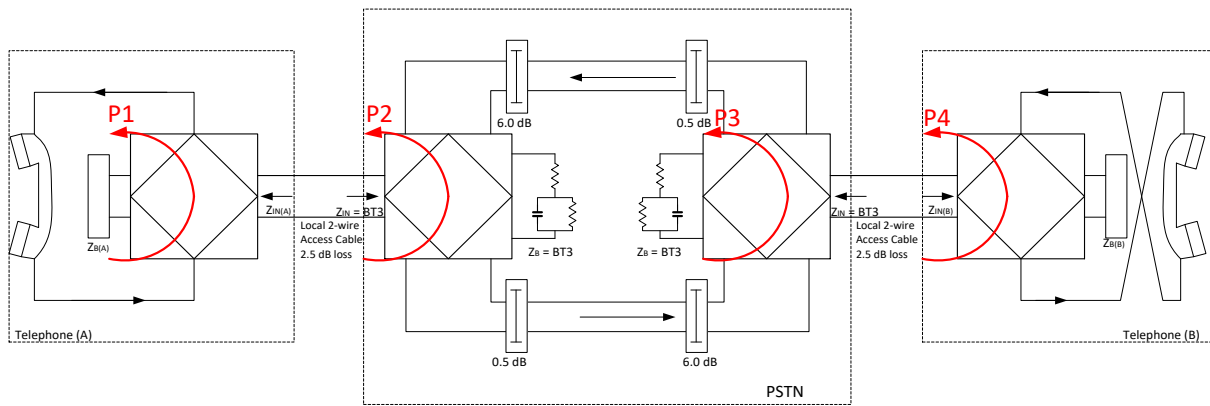

P1 is the component of the send power which is returned to the receiver as a result of mismatch between the input impedance of the PSTN (BT3) and the Balance Impedance of Telephone (A). It is perceived as sidetone.

P2 is the power reflected back towards Telephone (A) from the network interface due to the mismatch between the input impedance of Telephone (A) and the network Balance impedance (BT3). Due to the short propagation delay between Telephone (A) and the network interface this is also perceived as sidetone. If there were significant delay between Telephone (A) and the network. This component would start to appear as echo.

P3 is the component of send power (from Telephone (A)) which is sent back to Telephone (A). It is due to the mismatch between the input impedance of Telephone (B) and the balance impedance of the network at the Telephone (B) interface (BT3). It is perceived at Telephone (A) as increased sidetone if the network delay is small, or echo if the network delay is large (eg and international call).

P4 is the component of send power from Telephone (A) which is reflected back towards Telephone (A) as a result of a mismatch between the balance impedance of Telephone (B) and the input impedance of the network interface (BT3). It is perceived at Telephone (A) as increased sidetone if the network delay is small, or echo if there is significant network delay.

Notes:

Every time there is a mismatch there is not only an increase in sidetone or echo, but also the power received by Telephone (B) is reduced by the same amount.

The same degradations occur at Telephone (B) for signals transmitted to Telephone (A).

An Echo signal towards Telephone (A) is the same as a send signal from Telephone (B) and itself may be audibly echoed back to Telephone (B). This is known as listener Echo as against Talker Echo.

Where delays are significant echo cancellers are used to eliminate echo, but cannot restore the levels which are reduced by impedance mismatch. Echo cancellers also produce distortion which makes them unsuitable for circuits carrying facsimile or other voice band data traffic.

**FIGURE 4.6 End to end network schematic showing the effects of impedance mismatch on network performance.**

#### 4.4.3 Disabling of echo control devices

Echo control devices are designed specifically to improve telephone conversations. However, on some connections, they can cause greater problems than echo itself particularly the non-linear processor which can enhance voice by removing noise, but may destroy signals carrying valid data. These are typically connections between modems and facsimile machines. It is therefore necessary that echo control devices are capable of being disabled when required. For this reason, they are equipped with tone operated disablers designed to respond to a frequency of 2100 Hz. To disable the echo canceller the terminal at either end of the connection shall transmit a signal with the following characteristics:

Frequency: 2100 +/- 15 Hz

Phase change: 180 degrees +/- 25 degrees every 450 +/- 25 ms (the phase must have changed by 180 +/- 10 degrees within a period of 1 ms. During the phase change the level of the signal shall not drop more than 3 dB below the steady state value for more than 400 ms

Level: -31 dBm0 to 0 dBm0 (recommended -15 dBm0)

Duration 3.3 +/- 0.7 seconds

Out of band power: Signals other than the 2100 Hz shall be at least 15 dB below the 2100 Hz signal.

Distant end terminal: The terminal not transmitting the echo canceller disabling signal shall not transmit any signals above -46 dBm in the 200 to 4000 Hz band.

Note that transmitting the 2100 Hz tone without the phase reversals will not disable the echo cancelling process but should disable the non-linear processor only, which will remove some distortion which a modem is likely to be sensitive to. Most of the higher speed modems have their own echo cancellers so the network canceller is not required.

#### 4.4.4 Holding the disabled condition

The tone detector will hold the echo canceller and non-linear processor in the disabled state for any single frequency sinusoid in the band from 390 – 700 Hz having a level of -27 dBm0 or greater and from 700 – 3000 Hz having a level of -31 dBm0 or greater. The disabler will release where the signal in the band 200 – 3400 Hz drops below – 36 dBm0 for more than 250 ms.

#### 4.5 Balance about earth

The 2-wire network interface is balanced about earth, and to keep induced noise to a minimum it is important that customer equipment and cabling maintains this balance as much as possible. The Balance about earth requirements for Customer equipment are documented in the applicable PTC Specifications.

- *For CPE, Balance about earth across the voice band of 40 dB is a minimum requirement with 60 dB being recommended.*

## 5 SIGNALLING

### 5.1 Signalling types

(1) The standard method of signalling between customer premises equipment and Spark analogue network interfaces is dual tone multi-frequency (DTMF) signalling. This method is also widely used for signalling from customer to customer after a call has been established.

- *Reference ITU-T, Recommendation Q. 23.*

(2) (a) Historically, the standard method of signalling was decadic, consisting of trains of break pulses to indicate the digits signalled. The version of this system developed for use in New Zealand was unique in that the coding was the reverse of that used generally around the world. That is, when the number N is dialled, the number of pulses sent to line is 10 – N.

(b) The use of decadic signalling will not be available on any of the new network interfaces, and will only remain available on legacy TDM networks until it is phased out.

(3) Direct Dial-in (or 'DDI') operation is a particular type of signalling used between the exchange and the customer's equipment whereby the final 1 - 4 digits of the called number are sent from the exchange. DDI operation can use decadic or DTMF signalling, as required by the customer's equipment.

- *Further details of Analogue 2-wire DDI can found in PTC 107, although it should be noted that this type of interface will be phased out as legacy TDM exchange equipment is retired from service.*

### 5.2 DTMF signalling

#### 5.2.1 DTMF tones

(1) The allocation of DTMF signalling frequencies necessary to signal information to the network is as follows:-

LOW GROUP (Hz)	High Group (Hz)			
	1209	1336	1477	1633
697	1	2	3	A
770	4	5	6	B
852	7	8	9	C
941	*	0	#	D

- *The 'A', 'B', 'C' and 'D' signals are not currently used by the network but may be used in end to end communications.*

#### 5.2.2 DTMF Characteristics

The DTMF receiver will respond to DTMF signals in the following ranges:-

- Any receive level between -5 dBm and -20 dBm.
- High frequency pre-emphasis of between 0 and 3 dB.
- DTMF frequencies within  $\pm 1.8\%$  of the nominal values (ref. PTC200 clause 5.2.1(1)).

- (d) The receiver will recognise any valid DTMF signal that is present for a minimum of 60 ms, as long as it is preceded by a continuous pause of 60 ms.
- (e) The receiver will ignore breaks of up to 15 ms provided the signal either side of the break represents the same digit, and the break does not occur within 20 ms of the start or the finish of the tone burst.

The following DTMF signals will be rejected

- (f) A signal of less than 20 ms duration
- (g) A signal of less than -40 dBm
- (h) A signal in which either of the individual frequencies deviates by more than +/- 3.5% of the nominal frequencies listed in ITU-T recommendation Q.24.
- (i) Signals where any frequencies other than the correct DTMF pair are also present shall be rejected as valid DTMF if the total power of such frequencies is greater than the level of the lowest power valid frequency minus 20 dBm.

### **5.2.3 DTMF signalling between customers**

The received level of DTMF tones at the customer's premises when transmitted from a distant point in the PSTN, will on average be in the order of -20 dBm, but may be as low as -40 dBm depending on actual transmit level and length of line. If transmitted from other networks, it may in some extreme cases be even lower.

### **5.3 Recall (also known as timed break recall (TBR) or Hook-switch flash (HSF))**

This is used to activate special network features and is invoked by breaking the d.c. loop for a short period. The length of the break must be short enough not to terminate the call and long enough to be recognised. The network is designed to respond to range 500 to 800 ms, but will usually respond to times down to 350 ms.

## 6 D.C. LINE CONDITIONS

### 6.1 General

The d.c. conditions at customers' demarcation points on PSTN lines vary depending on the following:-

- (a) The type of line feed equipment used, and
- (b) The length of the line and type of cable used.

### 6.2 Exchange line feed equipment

(1) The nominal supply voltage used in local exchanges to feed PSTN lines is in the range 50 V to 90 V. However, for most lines a nominal 50 V power supply is used, having a tolerance range of 44 V to 56 V. The positive pole of the power supply is connected to earth (see Fig. 6.1).

- *Where the analogue interface is derived over fibre or wireless, there may be no connection to earth, i.e. the interface is floating.*

- *The exchange supply may be boosted to 90 V between the line wires on some long rural lines, but the voltage on each conductor will not normally exceed  $\pm 52$  V with respect to earth.*

(2) The line current supplied will normally be current limited. The limits will depend on the type line circuit used but can range from 80 mA down to 20 mA.

- *The low current limit feeds may be referred to as constant current feeds as in most cases they will be operating in the current limited mode.*

(3) Ripple components up to 2 mV psophometric may be present.

(4) Under normal network switching conditions step changes in the open-circuit voltage may occur within the limits stated.

- *A typical case of this is the "reversal on answer" supervisory signal. Other network conditions also result in short breaks in line current during the setting up of a call.*

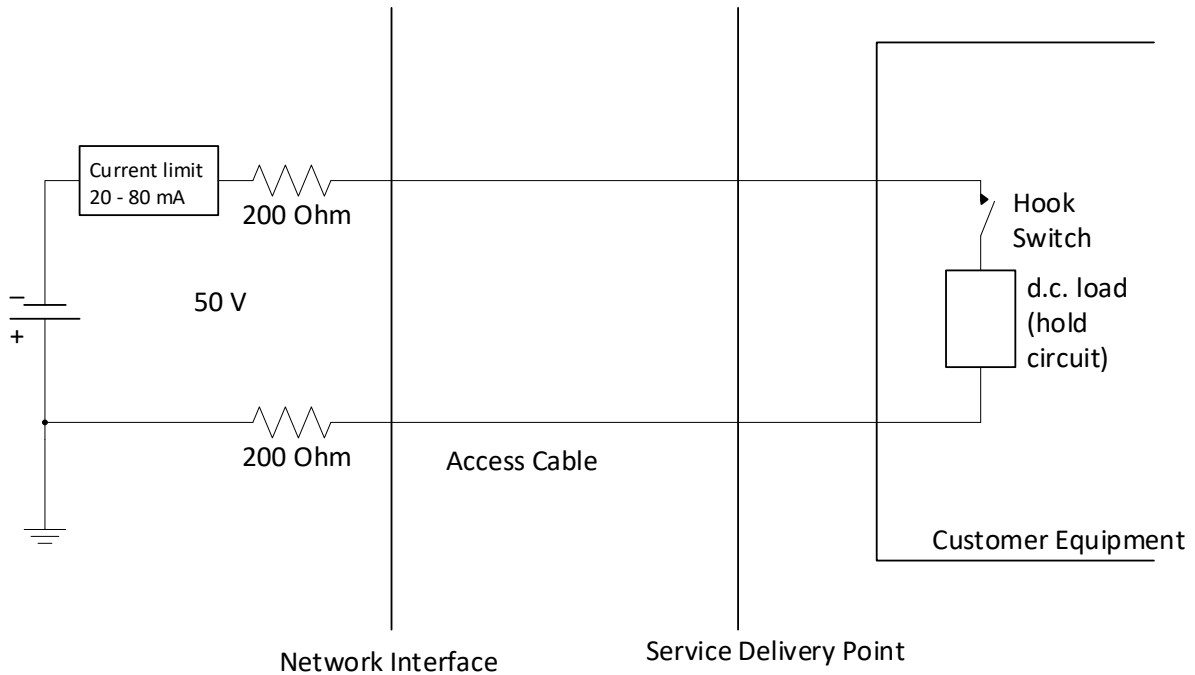

Note: The 200 Ohm resistors represent the d.c. impedance. At voice frequencies the a.c. impedance will be generally  $> 50,000$  Ohm. Historically this was achieved by the use of large inductors, but is now implemented using an electronic gyrator circuit.

**FIG. 6.1 EXCHANGE LINE FEED**

### 6.3 Derived circuits

- (1) Use of derived circuit equipment for all or part of the line between the core network and the customer, is widespread and on the increase. In such cases, the line feed current is produced an equipment terminal nearer to the customer.
  - (2) The analogue interface may be derived in a street side cabinet from a fibre feed, and reticulated to the end customer over conventional copper cable, or the fibre may go into the customer premises with the derived analogue circuit being connected directly into the premises wiring.
- *typically derived circuits provide lower current d.c. feeds than the old telephone exchange feeds.*

### 6.4 Line polarity

The polarity of the pair at the Service Delivery Point is not fixed and may change at any time following network maintenance.

### 6.5 Answer supervision

Answer supervision is provided on originated calls by means of a reversal of the line polarity when the called line is answered. The line polarity is again reversed should the called party be the first to release the call.

Line polarity reversal for answer supervision does not apply on the called party's line should the calling party release first. In this case, the only indication given to the called party is disconnect tone.

## 6.6 Clear Forward

Clear forward is indicated by a break of 800 to 1100 ms in the positive lead when the distant party terminates the call.

- *Answer supervision and Clear Forward are NOT part of the standard PSTN service and are only available on business lines on request. They may not be available on all lines.*

## 6.7 Voltage transients

(1) Changes to line conditions of up to 50 ms duration (for example, polarity, voltage, and feeding resistances) may occur during processing of a call by the network or by PABX's.

(2) Also, high voltages may occur in the event of power system faults or lightning strikes.

## 6.8 Line Tests

Maintenance staff may employ 500 V insulation resistance measuring equipment when testing lines connected to the PSTN. Such voltages will not be encountered on ATA derived circuits.

## 6.9 Requirements for terminal equipment

For various states, the following conditions apply:-

Line Condition	Loop Current-time
Seize line	>15 mA for > 10 ms
Hold line	>15 mA indefinite or time out after 10 seconds
Answer line	>15 mA for t > 40 ms
Release line	< 5 mA for t > 1000 ms
Hook-switch flash	< 5 mA for 500 ms < t < 800 ms



## 7 RINGING CHARACTERISTICS

### 7.1 Ringing frequency

The standard ringing frequency applied to PSTN lines is 25 Hz.

### 7.2 Ringing voltage

(1) For individual Spark PSTN lines, the conditions are as follows (see also Fig. 7.1):-

(a) The open circuit ringing voltage applied to line at the exchange is nominally 90 Vrms, dropping to 75 Vrms under the maximum rated load of the ringing generator.

(b) One side of the ringing generator is normally connected to earth at the exchange, and the other applied to one conductor of the line. The return path is via the other conductor to the exchange -50 V supply, the positive side of which is also connected to earth (see Fig. 7.1).

(2) For Spark PSTN service using derived circuit equipment, the conditions are:-

(a) On some derived circuits the ringing voltage may be somewhat less than in sub-clause (1) above, and the current available may be limited.

(b) The ringing voltage at the customer's premises should still be at least 10 Vrms.

(c) The ringing on derived circuits may be balanced about earth or not referenced to earth at all.

- *For derived circuit terminal equipment, the maximum distance between the ringing supply and the customer is normally less than in (1) above, so the higher source voltage is not necessary.*

### 7.3 Ringing current

The ringing current available at the customer's premises is limited by the source impedance, the line impedance and the series capacitor at the line interface. To ensure reasonable ringing performance, the total ringing load connected to a line should not exceed a RN of 5.

- *See Specification PTC 200 for details.*

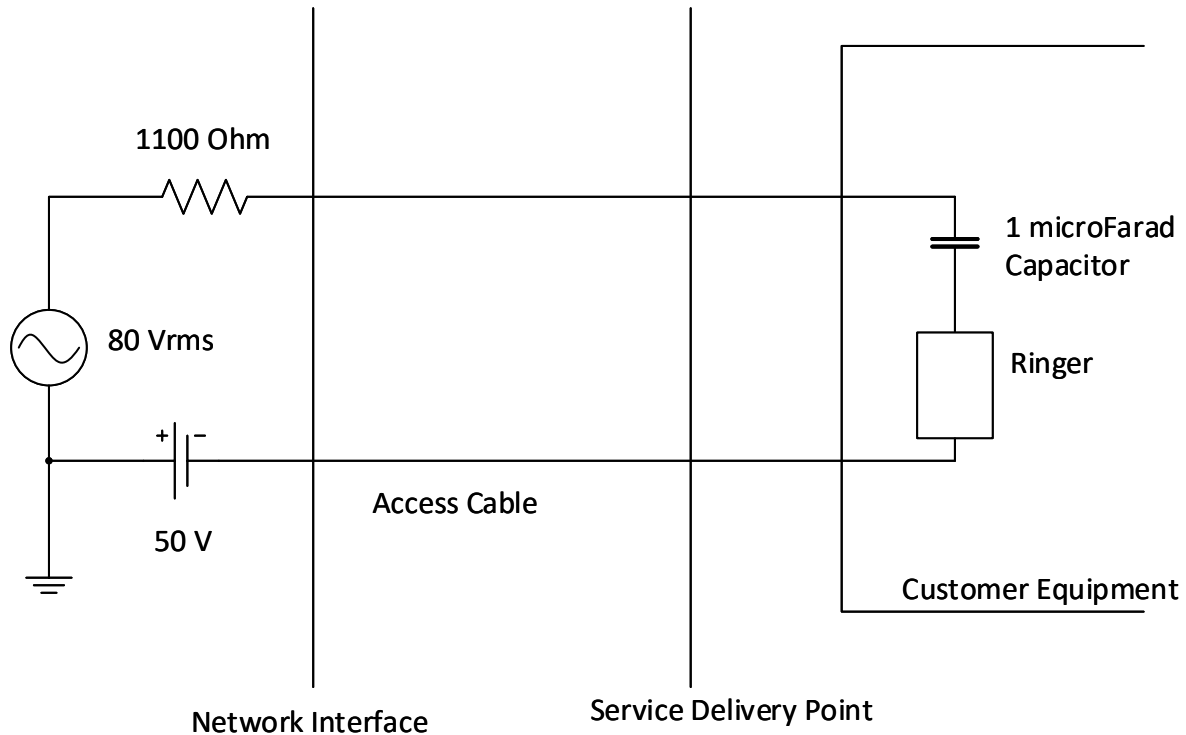

#### Notes:

Where service is provided via an ATA, the network interface and Service Delivery Point are effectively the same.

Where the network is delivered to the Customer Premises via Chorus Cable, there will be some loss in the Access Cable, although at 25 Hz this will be largely resistive, at approximately 168 Ohms per km.

A ringing load of  $R_N = 1$  (typical for a telephone) is the equivalent of a 1 micro-Farad capacitor in series with an 8 kOhm resistor. For a modem or facsimile machine the load is usually much lower than for a telephone as it needs only to sense the presence of ringing and not provide power for an audible ringer.

### FIG. 7.1 RINGING CONNECTIONS

#### 7.4 Ringing cadences

(1) There are four distinctive cadences available for use on individual customers lines, and these are designated as Distinctive Alerts 1 - 4 (DA 1 - 4). The purpose of using different cadences is to enable an individual line to be used for up to four separate functions (e.g. telephone, fax, modem and answerphone, can all be supported by the one line). Use of suitable decoding arrangements associated with the CPE allows the nature of the incoming call to be determined before it is answered and avoids the ringing of all devices unnecessarily.

- All ringing cadences may not be available on all connections.
- DA1 is the standard cadence and will always be available.

(2) The nominal cadences designated DA 1-4 are as follows, each cadence being repeated until the call is answered or abandoned:-

DA 1 (normal ringing cadence):

400 ms on, 200 ms off,  
400 ms on, 2000 ms off,  
and repeated.

DA 2 : 400 ms on, 2600 ms off,  
and repeated.

DA 3 : 400 ms on, 200 ms off,  
400 ms on, 200 ms off,  
400 ms on, 1400 ms off,  
and repeated.

DA 4 : 400 ms on, 800 ms off,  
400 ms on, 1400 ms off,  
and repeated.

(3) Some derived circuits prefix the above ringing cadences with a single 400 ms on period followed by a 2.6 second off period.

This extra burst of ringing is common on Fibre derived circuits where the ATA function is integral to the ONT. However some service providers use their own ATA and not the one integral to the ONT. These will usually adhere to the standard ringing cadences.

- *Ref TCF Document "SIP ATA Standard for LFC Wholesale Service (Loose Coupling) version: 1.31 Date 26 March 2015"*

(4) The calling party will hear the standard ringing tone (ref. clause 8.1 (1)) in each case.

(5) Ringing will time-out after 4 minutes if the call remains unanswered.

### **7.5 Tolerances on cadences**

In most cases, the cadence 'on' periods can be expected to fall within  $\pm 10\%$  of the nominal figures stated above in clause 7.4(3). However, in certain cases this can increase to  $\pm 20\%$ .

- *DA 4 is used in conjunction with Spark's "Faxability" service.*

(3) DA 2 and DA 3 are used on Centrex lines only, but may be allocated to other lines as required. Since DA 1 is the 'standard' ringing cadence, it is expected that this will usually be allocated to the 'main' telephone.

## 8 SUPERVISORY SIGNALS

### 8.1 Supervisory tones

(1) The following are the standard supervisory tones generated by equipment within the Spark TDM PSTN:-

Dial tone:	400 Hz continuous
Dial tone, with message waiting: (Note 1)	400 Hz interrupted, 100 ms on, 100 ms off, repeated for 2.5 secs then continuous until it times out
Busy tone:	400 Hz interrupted, 500 ms on, 500 ms off, repeated
Number unobtainable tone:	400 Hz interrupted, 75 ms on, 100 ms off, 75 ms on, 100 ms off, 75 ms on, 100 ms off, 75 ms on, 400 ms off, all repeated
Ringing tone:	400 Hz plus 450 Hz interrupted, 400 ms on, 200 ms off, 400 ms on, 2 sec off, all repeated
Disconnect tone:	400 or 900 Hz interrupted, 250 ms on, 250 ms off, repeated
Switching complete tone: (Note 2)	400 Hz plus 450 Hz interrupted, 200 ms on, 400 ms off, 2 sec. on, 400 ms off, all repeated

Call waiting tone:	400 Hz interrupted, 200 ms on, 3 sec. off, 200 ms on, 3 sec. off, 200 ms on, 3 sec. off, 200 ms on, not repeated
Call holding tone:	400 Hz interrupted, 500 ms on, 500 ms off, then 400 Hz plus 450 Hz interrupted, 500 ms on, 2.5 sec. off, all repeated

Note 1: "Message waiting" is for users of the Spark PSTN voice mail system indicating that a message is waiting.

Note 2: In addition to indicating "switching complete", this tone is used in place of conventional dial tone to warn a customer that the line has been set up either to divert incoming calls or for "do not disturb".

## 8.2 Tolerances on frequencies and cadences

In the Spark TDM PSTN, maintenance limits for supervisory tones are as follows:-

- (a) Frequencies are maintained within  $\pm 5\%$  of the nominal values quoted in clause 8.1(1) above.
- (b) Cadences are maintained within  $\pm 10\%$  of the nominal values quoted in clause 8.1(1) above.

## 8.3 Levels of supervisory tones

The tones are generated at -9 dBm0. At the exchange MDF they will be at -15 dBm, and will be received by the customer at a lower level depending on the loss in the access cable. Derived systems will be about 2.5 – 3 dB lower than this.

## 9 ANALOGUE ON-HOOK DATA TRANSMISSION

### 9.1 Introduction

(1) Analogue on-hook data transmission is a technique which enables information to be transmitted to the called party from the exchange during the ringing cycle, without that party going off-hook. The information is transmitted to the called party during the long silent period between the first and second ringing cadences (ref. clause 7.3).

- *A typical application of this facility is for the called party to receive information about the incoming call, such as calling party number (see Section 11).*

- *Ref. Bellcore TR-NWT-000030*

(2) This facility is supplementary to standard Spark telephone service. It is restricted to describing interfaces requiring connection of specialist CPE, and does not include services which use standard techniques such as DTMF tones for data transfer.

(3) The specification of this facility does not constitute a guarantee that it will be available in all circumstances.

### 9.2 Timing

The timing of the data transmission signal relative to the ringing cadence is as follows:-

- The signal starts not less than 500 ms after the first ringing cadence has ended, and,
- ends at least 200 ms before the start of the second ringing cadence.

- *For derived systems which prefix the standard ringing cadence with an a 400 ms burst of ringing, the data transmission takes place in the 2600 ms gap between the initial burst and the normal ringing cadence.*

### 9.3 Physical Layer

The physical make-up of the signal transmitted from the exchange is as follows:-

Modulation Type:	Frequency shift keying
Mark (logic 1):	1200 ± 12 Hz
Space (logic 0):	2200 ± 22 Hz
Transmission level:	-13.5 dBm ±1.5 dBm at the exchange into a standard BT3 termination
Transmission rate:	1200 ± 12 bits per second
Word format:	Each data word shall be preceded by a start bit (space) and followed by a stop bit (mark)
Word length:	8 bits
Bit order:	The least significant bit of each data byte shall be transmitted first

### 9.4 Data Link Layer

(1) In the data link layer, the Data Message Frame comprises the following (see Fig. 8):-

- Wake-up signal to alert receiver of impending transmission.
- Message.
- A checksum for error detection purposes.

(2) Details of the frame are as follows:-

- (a) Each frame commences with a Channel Seize Signal (CSS) and a Mark Signal.
- (b) The CSS consists of a block of 300 continuous bits of alternating "0"s and "1"s. The first bit transmitted is a "0" and the last bit a "1".
- (c) The Mark Signal consists of 180 mark bits.
- (d) The format of the Message portion of the frame is shown in Figs. 9.2 & 9.3.
- (e) The checksum is the last word of the frame. It is the 2's complement of the modulo 256 sum of each bit in the other words within the message.

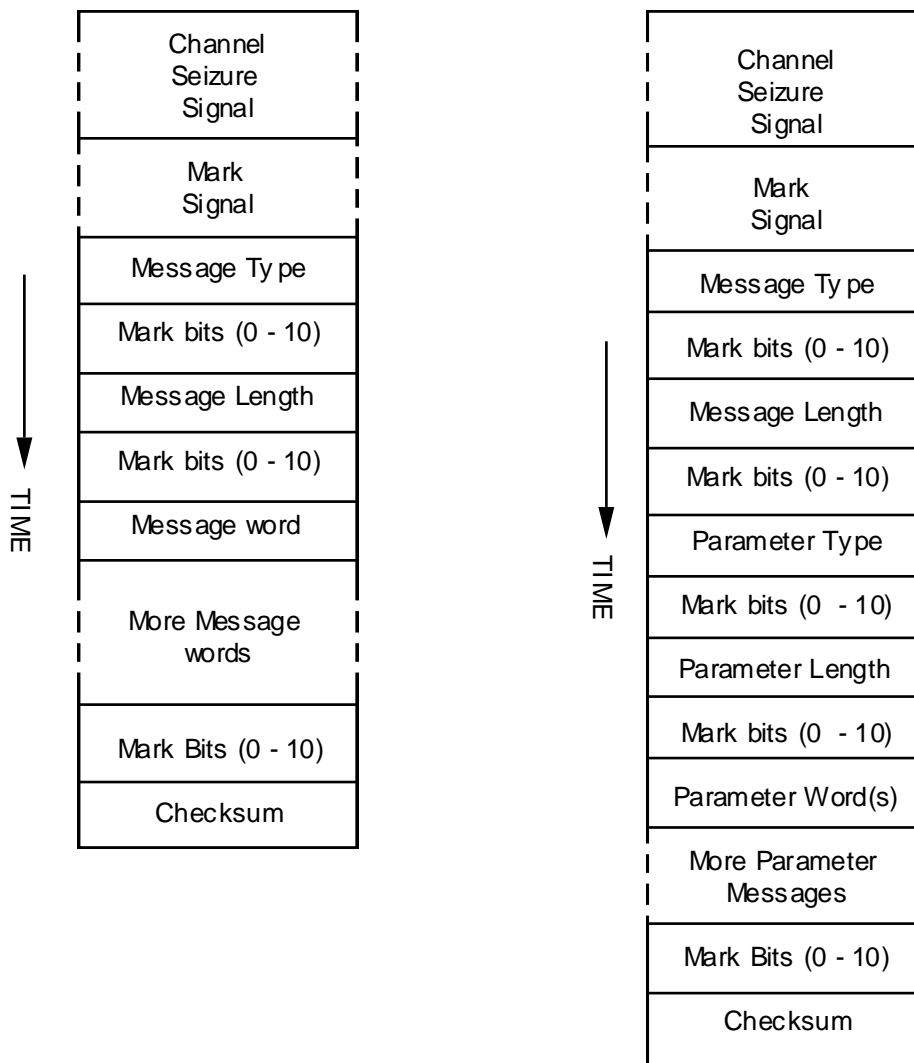

(a) Single Data Message Format (SDMF)

(b) Multiple Data Message Format (MDMF)

**FIG. 9.1 SINGLE AND MULTIPLE DATA MESSAGE FRAME FORMATS**

## 9.5 Message Assembly Layer

### 9.5.1 Types of message

There are two message types as follows (see Figs. 9.2 and 9.3):-

- (a) The Single Data Message Format (SDMF) which defines a message consisting of a message header and a message body.
- (b) The Multiple Data Message Format (MDMF) which defines a sequence of messages, each consisting of a message header and a message body. The message body may contain several smaller messages called parameter messages, each of which has a header and a body.

### 9.5.2 Single Data Message Format (SDMF)

The Single Data Message Format (SDMF) is as follows (see Fig. 9.2):-

(1) Header, consisting of:-

- (a) The 'Message Type', which is an 8-bit word identifying the feature generating the message.
- (b) The 'Message Length', which is an 8-bit word indicating the number of message words following in the message body (1 - 255).

(2) Message Body

The message body contains up to 255 8-bit words.

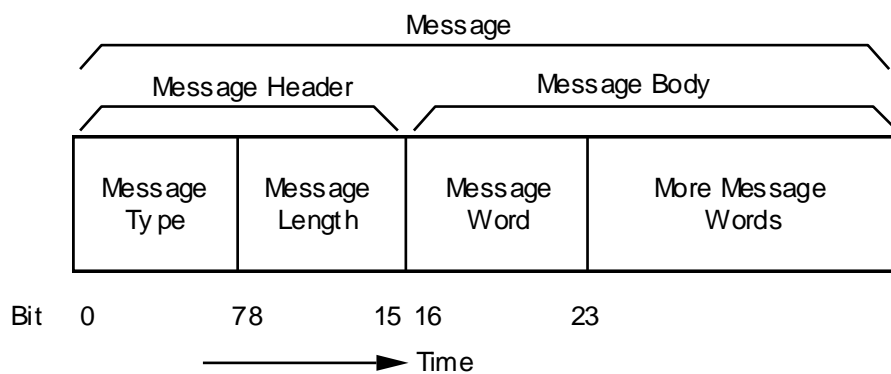

**FIG. 9.2 SINGLE DATA MESSAGE FORMAT (SDMF)**

- *In practice, the message body may be limited by the ringing cadence used.*



### 9.5.3 Multiple Data Message Format (MDMF)

The Multiple Data Message Format (MDMF) is as follows (see Fig. 9.3):-

(1) Header, consisting of:-

- (a) The 'Message Type', which is an 8-bit word identifying the feature generating the message.
- (b) The 'Message Length', which is an 8-bit word indicating the number of message words following (1 - 255). This includes the parameter message headers as well as the parameter message bodies.

(2) Message body:-

(a) Parameter Message Header, consisting of:-

- (i) The 'Parameter Message Type', which is an 8-bit word identifying the feature generating the parameter message.
- (ii) The 'Parameter Message Length', which is an 8-bit word indicating the length of the parameter message.

(b) Parameter Message Body containing a series of 8-bit words.

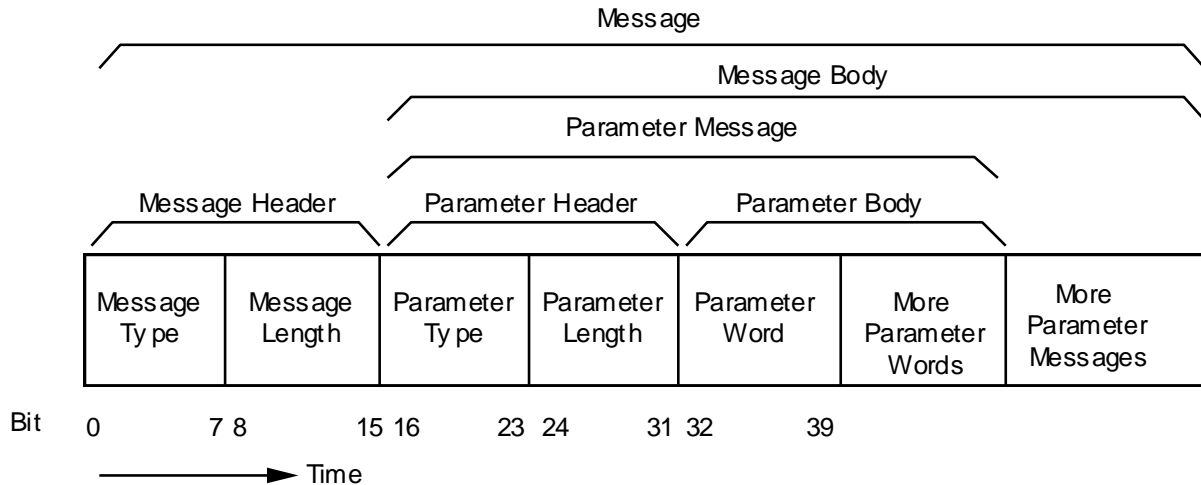

**FIG. 9.3 MULTIPLE DATA MESSAGE FORMAT**

## 10 ANALOGUE CALLING LINE IDENTIFICATION PRESENTATION

### 10.1 Introduction

Analogue Calling Line Identification Presentation (Analogue CLIP) is a technique which enables the directory number of the calling party to be transmitted to the called party during the ringing cycle. This enables CPE to receive the calling party number without going off-hook. The information is transmitted to the called party during the long silent period between the first and second ringing cadences using the analogue on-hook data transmission facility described in Section 10.

### 10.2 Information Format

(1) The PSTN will normally deliver the date and time of the call and the directory number of the calling party. The SDMF is normally used to carry the information, but where additional information is necessary, the MDMF is used. The formats of SDMF and MDMF are described in Section 10.

(2) In some instances, information can be conveyed by means of a coded "calling number" in place of the actual calling party identity (see Specification PTC 200, clause 11.4.5).

- *An example of this is used for international calls received via Spark's Gateway exchange. On all such calls, a calling number identity of "0000" is delivered, rather than use the "number unknown" or "not available" information category.*

### 10.3 Calling Number Delivery (CND)

#### 10.3.1 Using SDMF

(1) The message type is as follows:-

Message type	Service
0000100	Calling Number Identity

(2) Message Length:-

8-bit word with a binary value between 9 and 18.

(3) Message Body:-

(a) Date and Time of message: 8 words coded in IA5, with no parity.

(b) Calling line directory number (if available and able to be displayed):-

(i) Up to 10 digits coded in IA5 with no parity, or

(ii) IA5 character "P" if an anonymous indication is to be delivered in lieu of the calling line directory number as reason for absence of directory number, or

(iii) IA5 character "O" if an out-of-area/unavailable indication is to be delivered in lieu of the calling line directory number as reason for absence of directory number.

- *For the purposes of this Document, IA5 is the same as ASCII*

**10.3.2 Using MDMF**

(1) The message type is as follows:-

Message type word	Service
10000000	Call Setup

(2) Message Length:-

8-bit word with a binary value between a minimum of 13 and up to a number dependent upon the number of messages.

- *The absolute maximum binary value is 255 (ref. clause 10.5.2)*

(3) Message Body

The message body is made up of the following parameter messages:-

- Date and Time, and
- Directory number, or reason for absence of directory number.

(4) The Parameter Type Values are as follows:-

Parameter type Value	Value Parameter
00000001	Date/Time
00000010	Calling Line Directory Number
00000100	Reason for absence of Directory Number

(5) Parameter Message Format

There are 3 parameter message formats, as follows:-

(a) Time and Date Message Format:-

1	Date and Time parameter type code (00000001)
2	Parameter Length (8)
3 4	Month (01 - 12)
5 6	Day (01 - 31)
7 8	Hour (00 - 23)
9 10	Minute (00 - 59)

(b) Calling Line Directory Number Parameter:-

1	Calling line Directory Number parameter type code (00000010)
2	Parameter Length (up to 10)
3 4 . . . Up to 10	Digit 1 Digit 2 . . . Digit 10

(c) Reason for absence of Calling Directory Number Parameter:-

1	Reason for absence of Directory Number; parameter type code (00000100)
2	Parameter Length (1)
3	Reason ( P or O)

## 11

**VISUAL MESSAGE WAITING INDICATION****11.1 Introduction**

Visual Message Waiting Indication (VMWI) will be available only on Spark lines which also provide Analogue calling Line Identification Presentation ("Caller Display") service. Unlike "Caller Display", signalling is independent of ringing. Signal transmission is enabled only for those customers subscribing to Spark's "Call Minder" or "Message Manager" services. In such cases, "on" or "off" signals are typically transmitted within 15 seconds of either the incoming message being completed or a stored message having been listened to. However, in some circumstances, this may be delayed.

**11.2 Information format**

- (1) Information format is as specified in Section 10 for Multiple Data Message Format (MDMF).  
 (2) The message type is as follows:-

Message Type word	Service
10000010	Message Waiting notification

- (1) The message body is as follows:-

Parameter Type	Date and Time	00000001
Parameter Length	Length of Date and Time	00001000
Month, Day, Hour, Minute	See clause 9.3.2(5)	

Parameter Type	Visual Indicator	00001011
Parameter Length	Length of Visual Indicator	00000001
Visual Indicator	Indicator On	11111111
Visual Indicator	Indicator Off	00000000

## **12 CUSTOMER SERVICE DELIVERY POINT PHYSICAL INTERFACE**

### **12.1 Historical**

In the 1980s, The New Zealand Post Office adopted the British Telecom wiring system in which the first socket (master socket) derived a third wire which carried the ringing signal. The three wires were then connected to all other jack-points in the premises. When a phone dialled out, contacts on the dial shorted the third wire which prevented the bells in the other phones from sounding in response to the dial pulses. This was an era where most phones used decadic (pulse) dialling. However, within a relatively short period, almost all new phones used DTMF for dialling and there was no need for to suppressing ringing while dialling. The third wire was an elegant solution when it was first adopted, but as high speed modems came on the market in the 1990s and eventual DSL technologies in the early 21<sup>st</sup> century, the third wire became problematic as it unbalanced the line, and limited the speed available from high speed modems.

Spark (then Telecom) changed its practices in two steps. Firstly, the premises was wired with two wire only, but each socket derived the third wire in case the CPE connected to it was 3 wire. After a further period, the ringing capacitor was removed altogether and in the interests of reliability, all the pins which were no long used were removed from the socket. This became known as the 2-wire, 2 pin jack. This version also has a number of design features to protect against corrosion from moisture which is prevalent in many of New Zealand's older houses.

### **12.2 Current Practice**

BT 2-W 2-p jack-points are still available and in widespread use. However, for new installations it is recommended that the wiring practices are followed as documented in the TCF Premises Wiring Cable Installers Guidelines for Telecommunication Services. This document can be downloaded from [www.TCF.org.nz](http://www.TCF.org.nz) .

The TCF Premises Wiring Cable Installers Guidelines for Telecommunication Services, recommends 8-way RJ 45 socket are used throughout the premises. These are cabled back to a cabinet with patching facilities so that the CPE used is matched to the appropriate signals. The signal source may be a copper pair from a local telephone exchange, or an ATA situated in the cabinet. The ATA itself will usually have RJ11/RJ12 sockets for the analogue voice interface.

### **13 SUMMARY OF DIFFERENCES BETWEEN INTERFACES DELIVERED BY DIFFERENT TECHNOLOGIES**

Generally, CPE which meets the requirements of PTC 200 should work on analogue services delivered on all technologies. There are some minor differences which are documented as follows:

#### **13.1 Transmission**

The transmission plans are consistent across all technologies. The following differences are noted:

There is likely to be greater delay on derived circuits, particularly those using wireless and VoIP technologies. This could add up to 100 ms on top of the delays due to propagation time.

Derived circuits are likely to impact on the performance of voice band modems including facsimile machines. The CPE will usually fall back to a lower speed and the expectation is that 14.4 kbps should work satisfactorily.

#### **13.2 Signalling**

All signalling must use DTMF. Decadic signalling will continue to work on the Spark TDM network, but there are no guarantees that any particular line currently connected to a TDM exchange will remain connected. Decadic signalling is not provided for on any of the derived circuits.

Special facilities for use with PBXs may not be available on derived circuits, and are likely to be phased out over time digitally connected PBXs continue to replace analogue connected PBXs.

#### **13.3 d.c. line feed**

There are likely to be different current limits set for different lines, but PCT 200 compliant CPE will work on all circuits. One other difference which is unlikely to be significant is that the positive leg of the line is connected to a d.c. earth. To maintain a.c. balance, the voice frequency impedance to earth is high, in the order of 50 kOhm. Derived circuits are generally floating about earth.

#### **13.4 Ringing**

The voltages and frequencies are the same. However, some derived circuits, and in particular those documented by the TCF document: SIP ATA Standard for LFC Wholesale Service (Loose Coupling) version: 1.31 Date 26 March 2015, insert an additional 400 ms burst of ringing 2600 ms before the standard cadences. This may cause facsimile machines which use Spark's FaxAbility service to fail. It is understood that some facsimile manufacturers have modified their machines to cater for this difference.

Ringing output from a derived circuit may not be referenced to earth.

#### **13.5 Supervisory tones**

These are the same across all technologies.

#### **13.6 On-hook Analogue data**

The frequencies and timings are the same across all technologies.

**13.7 Caller ID presentation**

There is some variation between different technologies. The original Spark number format sent out from TDM exchanges was in the form 'Area Code + Director Number'. Some ATA devices use the format '0 + Area Code + Directory Number'. Some CPE manufacturers include the option for responding to either of these formats.

**13.8 Visual Message Waiting Indicator**

The same format is used across all technologies.

**13.9 Physical connection**

A variety of different connection methods are likely to be encountered, but all technologies should increasingly become connected as per the TCF wiring code of practice.

=====