

PTC220**Requirements for Private Voice Networks connected to the PSTN/ISDN****CONTENTS**

Foreword	2
Telecom Disclaimer	3
1 Scope	4
2 General	7
3 Definitions	13
4 Transmission	14
5 FXS Requirements	28
6 FXO Requirements	41
7 FXD Requirements	57
8 System Specific (including IP) Telephone Requirements	66
9 Voice Mail system Requirements	72

FOREWORD

The purpose of this Specification is to ensure that the ITU-T Recommendations for overall end to end performance are satisfied when private voice networks are connected to the Telecom network. This Specification covers the minimum technical requirements for the grant of Telepermits for such connection.

This Specification also covers a broad range of recommended parameters to assist those manufacturers who wish to exceed the stated minimum requirements. This Specification makes a clear distinction between these “mandatory” and “voluntary” performance requirements.

The coverage of this Specification includes the full range of private voice networks from a simple single line FSO/FXS system to a large multi-node private voice network with multiple gateways into the PSTN and ISDN.

This Specification includes the definition of requirements which ensure a reasonable expectation that private network users will be able to make calls into, and receive calls from the Telecom network.

This Specification includes provisions for key aspects only to be tested. Other aspects affecting performance indirectly or in only a few network situations are not a part of the formal test requirement for the grant of a Telepermit. Nevertheless, for reliable operation under all circumstances, these additional aspects need to be complied with.

Private voice networks are increasingly using packet technology to achieve cost savings by enabling voice and data to be transported and switched by common equipment. The voice performance of such networks can be affected by network topology, network provisioning, and network loading, which are all outside the scope of a PTC Specification. For the purposes of PTC testing, the equipment is configured in such a way that any degradation due to network design is minimised. It should be noted that in a real network implementation the performance can be no better than the results from the PTC tests.

The Telepermit system requires that suppliers accept responsibility for the quality and reliability of their products. The granting of a Telepermit is not an acceptance of such responsibilities by Telecom, nor is it an endorsement of that product by Telecom. It is simply a public statement that the product concerned may be lawfully connected to the Telecom network. Under New Zealand consumer legislation, suppliers have legal responsibilities to ensure that their products are suitable for their intended purpose. As such, they are responsible for ensuring that any conditions relating to the grant of a Telepermit are made known to their network designers, installers and customers.

TELECOM DISCLAIMER

Telecom makes no representation or warranty, express or implied, with respect to the sufficiency, accuracy, or utility of any information or opinion contained in this Specification. Telecom expressly advises that any use of or reliance on such information is at the risk of the person concerned.

Telecom shall not be liable for any loss (including consequential loss), damage or injury incurred by any person or organisation arising out of the sufficiency, accuracy, or utility of any such information or opinion.

The grant of a Telepermit for any item of terminal equipment indicates only that Telecom has accepted that the item complies with minimum conditions for connection to its network. It indicates no endorsement of the product by Telecom, nor does it provide any sort of warranty. Above all, it provides no assurance that any item will work correctly in all respects with another item of Telepermitted equipment of a different make or model, nor does it imply that any product is compatible with all of Telecom's network services.

1

SCOPE

1.1

Equipment covered

This Specification covers the requirements for private voice networks which are connected as customer equipment to the Telecom PSTN/ISDN. It is not technology specific, and is intended to cover traditional circuit switched PABXs as well as VoIP networks and wireless technologies such as DECT. It replaces PTC207 and PTC217.

1.2

Telepermits

Telepermits will be generally be granted for complete systems – i.e. network interface (FXO) and packet phones and/or analogue ports (FXS). Telepermits may be also granted for components of a system, but must be tested as a complete system (see Appendix 1), and where a component is granted a Telepermit, the other compatible component required to make up a complete functional system must also be Telepermitted. Telepermits will generally be granted in the PTC220 series.

1.3

Electromagnetic interference (EMI)

1.3.1

Radiated energy requirements

(1) All equipment shall comply with the Radiocommunications Act 1989 and Radiocommunications (Radio) Regulations 1993 as regards radiated energy. These requirements are administered by the Ministry of Economic Development and responsibility for such compliance rests with the Telepermit applicant.

- *Any microprocessor-based equipment is likely to give rise to unwanted radiation and it is advisable that this aspect be checked before any equipment is released onto the New Zealand market.*

(2) Ministry of Economic Development compliance requirements for EMC are not part of Telecom's requirements and, as such, are not pre-requisites for the grant of a Telepermit.

- *More information can be obtained from the Ministry's Website at http://www.med.govt.nz/pbt/rad_spec.html*

(3) There is currently no formal Telecom requirement for the degree of immunity from electromagnetic fields other than where it affects compliance with other requirements of this Specification. This is regarded as a marketing issue.

1.3.2

Immunity from radiated energy

It is strongly recommended that all devices satisfy the requirements for immunity to radiated electromagnetic energy as stated in the joint Australian and New Zealand standard, AS/NZS 4252.

- *The acceptable equivalent European standard is CENELEC/CEN 50082-1:1992.*

1.4

Legal requirements

Under the terms of Section 106 of the Telecommunications Act 2001, nothing shall be connected to a telecommunications network without the agreement of the network operator. For connection to the Telecom network, any device shall comply with Telecom's PTC specifications and display a label as evidence that a Telepermit has been granted.

- *The display of a Telepermit label clearly indicates to customers that the device may lawfully be connected to the network (ref. Specification PTC 100).*

1.5

Mandatory requirements

(1) All mandatory requirements of this Specification are denoted by use of the word "shall".

(2) The requirements of such clauses are also included in the test schedule detailed in Appendix 3. These requirements will, in general, be regarded as the minimum requirements for the grant of a Telepermit from 1 July 1996.

1.6

Exemptions from full compliance

(1) Notwithstanding the statement in clause 1.5 above, Access Standards reserves the right to grant exemptions to any mandatory requirements of this Specification where considered appropriate.

1.7

Warning to Suppliers

(1) Compatibility between the Telecom network and any type of equipment covered by this Specification is necessary for satisfactory operation. To ensure that the maximum degree of compatibility is achieved, the equipment should fully comply with this Specification.

(2) It is not possible to guarantee compatibility in every conceivable situation and, similarly, it is not possible or practicable for Telepermit testing to cover every situation. Nevertheless, the majority of operating conditions are covered by the testing requirements defined in Appendix 3.

(3) Suppliers should note that equipment which is not fully compliant with this Specification may suffer a higher proportion of service problems than that which complies in all respects. The cost of dealing with such problems will normally be borne by the customers involved.

- *Suppliers should also note that under the Fair Trading Act 1986 and Consumer Guarantees Act 1993, customers may have the right to pass on this cost to the supplier.*

1.8

Non-compliance aspects

All applicants for Telepermits covered by this Specification shall investigate those areas indicated by the Testing Authority as being non-compliant. The Telepermit application shall incorporate either:-

(a) evidence that the product has been suitably modified to fully comply with this Specification, together with an explanation of the arrangements made to ensure that these modifications will be carried out on all future production units, or

(b) an explanation giving justification for non-compliance, together with a statement of the applicant's intentions regarding the product's future compliance.

1.9

Warning notices

(1) There are many instances where the applicant is required to insert a warning notice in the User Manual for the product. This usually applies when devices are not fully compliant with recommendations. In such cases, the grant of a Telepermit is conditional on the warning notices being inserted, and it is the responsibility of the Telepermit holder to ensure that the customer is fully aware of them.

(2) To fail to pass on this information may be in breach of the Consumer Guarantees Act 1993, and may result in the Telepermit holder being liable to compensate the user for any Telecom call-out charges.

(3) It is recommended that all warning notices in the User Manual be incorporated either in one place or, preferably, at the appropriate places within the text. This reduces the risk of the information being overlooked.

- *These warnings assist both the supplier and the user, as they explain what is required or what restrictions apply to the product in service. As such, they inform the user and are also likely to protect the supplier under the Consumer Guarantees Act.*

1.10

Product and service compatibility

(1) This Specification deals with Telecom's requirements for ensuring compatibility with the basic functions of its network. As such, the granting of a Telepermit does not necessarily imply that a product is compatible with all of Telecom's supplementary services. Similarly, any two products which have been granted Telepermits are not necessarily fully compatible with one another.

1.11

Ongoing compliance

In all cases where a modification is necessary for a product under test to comply with Telepermit requirements such modifications shall be applied to all items of that product supplied to the market. For ongoing compliance, such modifications shall be applied to all future batches of the product supplied. **2**

GENERAL

2.1

Mode of presentation

(1) The requirements of this Specification are printed in plain type with each paragraph formally numbered. Informal comments, recommendations and explanations which are added only as indications of the means of compliance with this specification are shown in italics. Smaller type is used and each paragraph is preceded with a "•" symbol instead of a clause number.

(2) Mandatory requirements are indicated by use of the verb form "shall".

(3) Voluntary and preferred requirements or recommendations are indicated by use of the verb forms "should" or "may".

2.4

Marketing features

Some equipment features or characteristics are regarded as purely marketing issues and their requirements are therefore not necessarily dealt with in this Specification. However, in cases where clarification is considered desirable, explanatory notes are provided.

- *Although regarded as marketing features, it is a requirement that they be included in the features list referred to in clause 2.4 below.*

2.5

Specialised services & features

It is a mandatory requirement for all Telepermit applications that a complete list of functions/features for the product concerned be included. This may be part of a test report or as a separate list associated with the application form.

2.6

Variants of the same basic design

(1) Where the same basic design (particularly any electro-acoustic aspects) is common to a number of variants of a product, the required sample of units may be selected from the range of models offered. As a result, a number of variants may qualify for individual Telepermits based on the one series of tests.

- *To be regarded as the "same electro-acoustic design", the variants of any telephony device concerned shall use the same types of transducers (microphone and receiver), the same handset geometry and construction, and the same associated transmission and signalling circuitry. For other categories of product, the same line interface circuitry shall be common to all variants.*

(2) This also applies where two or more versions of an equipment are marketed and the only difference is in the quantity of identical modules used.

(3) In assessing the test results the Testing Authority shall be satisfied that the same basic design is used and that all variants meet the requirements of this Specification.

(4) A separate Telepermit will usually be issued for each functionally different model so that the general conditions of the Telepermit system can be applied independent of the performance of other models.

2.7

Equipment Configuration profiles

(1) Much of the equipment covered by this specification is highly configurable by software, firmware or configuration processes performed at installation time.

(2) When equipment is submitted for testing the correct configuration details and instructions for connection to the Telecom Network shall be supplied to the Test Laboratory. These details and instructions shall be same as those intended to be supplied to the end customer or installer.

(3) It is preferable that configurations compliant with Telepermit requirements are preloaded prior to supply, or invoked by a simple "NZ" command.

(4) Configuration profiles shall not be lost in the event of a power failure.

(5) Critical configuration details, i.e. network compatibility parameters such as loudness ratings, ISDN profiles etc, shall not be accessible by ordinary users.

(5) Remote configuration procedures shall have adequate security to prevent hackers obtaining access to system configuration files.

2.7

Electrical safety

2.7.1

General

All equipment intended for connection to the Telecom network, including plug-in cards and modules, shall conform to the safety requirements of the joint Australian and New Zealand standard, AS/NZS 3260:1993 (or later version).

- *This should not be confused with the definition of ELV applicable to electrical wiring covered by the New Zealand Electricity Regulations, where it is defined as 32 Vac rms and 115 V dc.*
- *A considerable proportion of telecommunications equipment available is manufactured for the North American and Japanese markets, where the mains voltage is only 100-110 V. Such overseas equipment may be compliant with the North American local requirements, but designed with inadequate internal clearances between its components to meet New Zealand requirements, which are based on 230 V operation.*

2.7.2

External power supplies

(1) Where the equipment is to be used with a separate external power supply, the combination of equipment plus power supply shall comply with the requirements of AS/NZS 3260:1993 or later equivalents.

- *Compliance testing to AS/NZS 3260, may only be undertaken by an IANZ registered laboratory, one which has been accredited by an IANZ affiliated laboratory registration authority, or one which is recognised by the Operations and Risk Management Division of the Ministry of Commerce.*

(2) Where the equipment is to be used with a separate external power supply and a non-proprietary power supply is used, the operating voltage and current rating (and preferably the polarity of the connector) should be marked on the case adjacent to the socket concerned.

- *This recommendation avoids the risk of an unsuitable power supply being connected via a standard or commonly used type of connector.*

(3) Where a battery charger is used and this can be connected to the equipment while the equipment is simultaneously connected to the Telecom PSTN line, such chargers shall comply with the requirements of AS/NZS 3260:1993.

2.7.3

Earth connections

(1) Where, for any reason, an earth connection is necessary for the correct operation of any equipment, the requirements of AS/NZS 3260:1993 shall be complied with.

- *Suppliers should note that such telecommunications equipment is referenced to both the local earth and the remote telephone exchange earth. In the event of power faults or lightning strikes causing a rise in earth potential in the vicinity of the customer's premises, insulation breakdown is likely to result.*

(2) Details of any earth connections required and the most appropriate ways of providing them shall be incorporated within the 'User Instructions' supplied with the equipment concerned.

2.8

Temperature

All products should be compliant with this Specification at all temperatures in the range -10 degrees C to +40 degrees C.

2.9

Compliance testing

2.9.1

Test procedures

(1) The sampling evaluation and test procedures required for granting a Telepermit for any product covered by this Specification are detailed in Appendices 1 and 2.

(2) The selection of tests applicable to the stated features of the product is the responsibility of the Testing Authority. For this reason it is important that details of all available features be supplied by the applicant. If the Testing Authority is not advised of all features and additional ones are discovered after a Telepermit has been granted, then it may be necessary for the product

to be retested. Where there is any doubt, the matter should be discussed with Access Standards, preferably prior to commencement of testing.

- *A subsequent retest is likely to involve the applicant in greater cost than if all features were declared originally.*

(3) For some complex devices the Testing Authority may have difficulties performing the necessary tests. In such cases, the Applicant shall provide the necessary liaison to ensure that the Testing Authority has sufficient information to readily perform the tests. It is recommended that specific complexities be discussed with Access Standards in the first instance, particularly if the device incorporates any process such as adaptive self-adjustment of its parameters.

- *This applies particularly if the device is dependent upon host equipment for operation.*

(4) The Testing Authority may be able to modify the device temporarily to meet the Telepermit requirements, but is under no obligation to do so. Full details of such modifications shall be included with the test report and furnished as part of the application.

- *Such modifications are likely to increase the cost involved and the overall time taken for the testing process.*

(5) Tests and measurements are to be carried out with the equipment functioning normally, and the relevant requirements of this Specification shall be complied with under normal working conditions. Where appropriate, the following shall be made available to the Test Laboratory:-

(a) Information on the most suitable means of disabling any automatic facilities during the test programme.

- *Unless suitable procedures are provided by the supplier, it may be necessary for the Testing Authority to spend additional time defining suitable test methods. Such activity will normally result in additional cost to the Applicant.*

(b) Any equipment or software necessary for the initialisation of the device under test.

- *Some equipment is dependent on an external device (e.g. a computer) and time can be wasted attempting to set up or initialise a device before tests can be carried out.*
- *Equipment that complies only under non-operational conditions is not acceptable for the grant of a Telepermit.*

2.9.2

Test results

(1) Full test results in the form of a Test Report issued by the Testing Authority, which should include colour photographs, shall be provided in support of all Telepermit Applications.

(2) Such Test Reports shall be in a format as close as practicable to that given in the Test Schedule shown in Appendix 3 of this Specification. All tests shall be addressed, stating "NA" where a test is not applicable.

(3) Photocopies of original Test Reports shall be accompanied by either colour photographs or colour photocopies of the product.

(4) All Test Results shall be relevant to the product in the form in which it will be offered for connection to the Telecom Network. It is not permitted to use different software and hardware settings simply to meet different clause requirements.

(5) In cases where equipment has been previously tested on behalf of another Telecommunications Authority, the resultant test results may be submitted to Telecom as additional support for a Telepermit application. Such test results must be relevant to the appropriate PTC Specification requirements for them to be considered for the grant of a Telepermit. In general, Authorities' compliance certificates alone are not sufficient for acceptance.

- *Test reports provided by overseas testing laboratories may provide more or less detail than is required by this Specification. Such reports are acceptable as supporting evidence, but additional tests to cover any Telecom requirements which differ from such standards may have to be carried out.*
- *A composite Test Report to the required format is to be supplied, but this may be prepared from several other separate reports.*

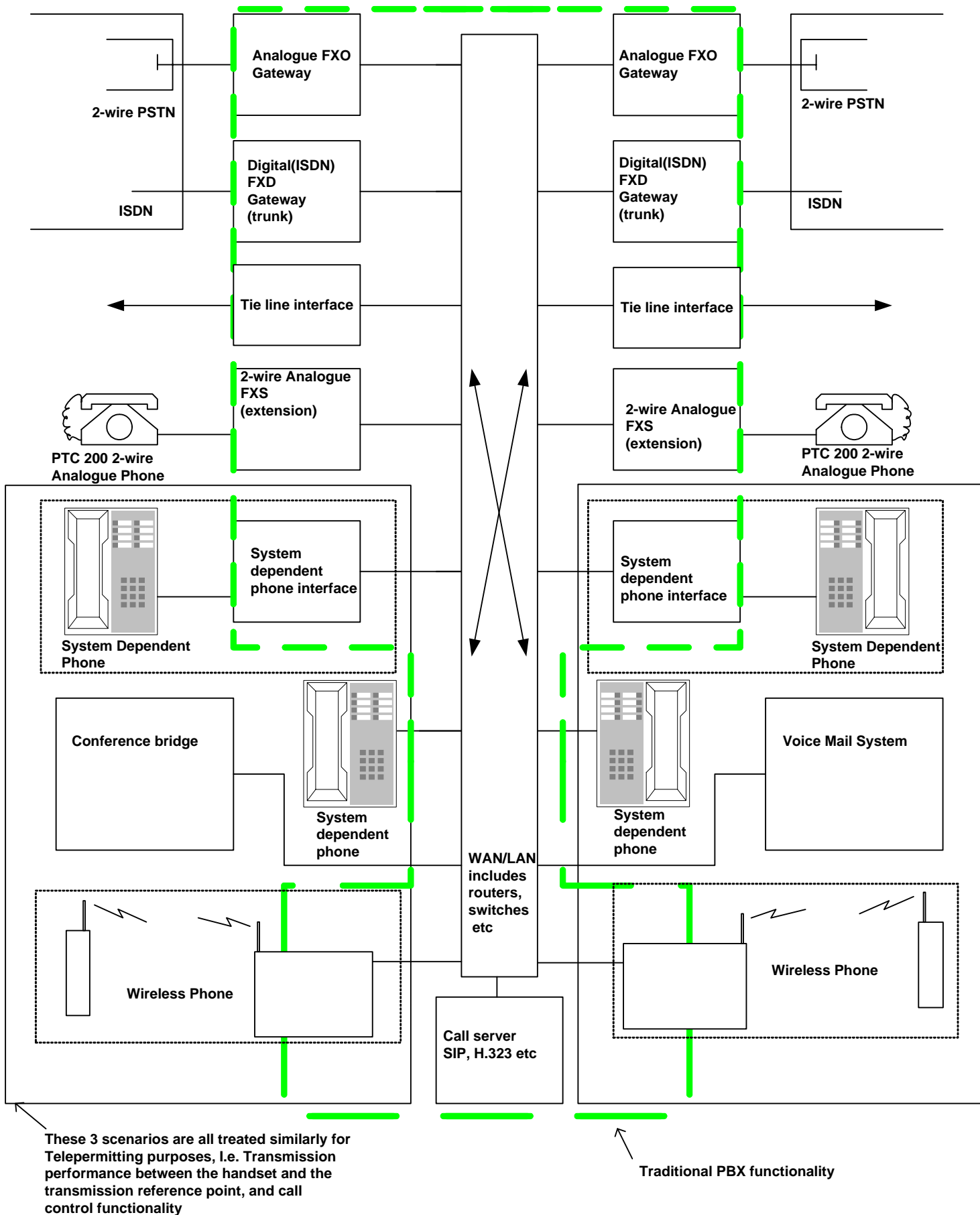

Fig 3.1 Elements of a private voice network

3**DEFINITIONS****3.1****General**

(1) The basic elements of a private voice network are shown in figure 3.1. The centre block labelled WAN/LAN could be implemented using a number of different technologies, for example analogue crosspoint switch, TDM digital, IP/Ethernet, or wireless. While the majority of such systems will have some form of switching included, the specification is also applicable to simple point to point loop extenders employing digital/analogue or wireless technologies.

(2) It has been noted that some terms have been used by manufacturers in different ways. For the avoidance of confusion over terms used in this Specification, they are defined as follows:-

ATA: Analogue Telephone Adapter. See FXS below

FXS: Foreign eXchange Subscriber interface . This equipment interfaces a transmission link to standard PTC 200 compliant CPE. The transmission link is commonly IP based in distributed network solutions, and will be connected back to a central office switch via an FXO interface. The same functionality exists in a PBX extension module, although the transmission link may be the backplane in the equipment cabinet, and the protocols proprietary.

FXO: Foreign eXchange central Office interface. This equipment interfaces a transmission link to a 2-wire analogue port on a central office switch. See also FXS, FXD. In PBX terminology this functionality would be contained in an analogue trunk module.

FXD: Foreign eXchange central office Digital interface. This equipment interfaces a transmission link to a digital port, either E1 or ISDN on a central office switch. See also FXS, FXO. In PBX terminology this functionality would be contained in an ISDN or E1 trunk module.

Acoustic Reference Level (ARL): The acoustic level which gives -10 dBm0 at the digital reference point.

D-factor: The computed average of the difference between the sending sensitivity using an artificial mouth and that using a diffuse room noise source.

TRP: Transmission Reference Point, also known as the 0 dBr point. Point within network where losses are measured from and to.

4

TRANSMISSION

4.1

General

This section covers parameters which deal directly with the quality of the voice signals themselves. They include transmission level plans, impedance plans (for analogue interfaces), delay plans, and methods of managing distortion. The test requirements for network elements, such as FXS equipment, system dependent (such as IP) phones etc are covered in detail in sections 5 on.

4.2

E-model

(1) When PTC 207 and PTC 217 were written, transmission impairments were dealt with using Quantization Distortion Units (QDUs). These were originally intended to quantify the distortion for an A or mu law codec pair in such a way that the overall effect of multiple conversions between analogue and digital could be assessed by adding the QDUs together. While QDUs were assigned to low bit rate encoders based on group assessment processes, these were found to be inadequate for all but very simple networks. The E-model was subsequently developed by ETSI to take account of all the impairments which lead to speech degradation, and in particular takes into account impairments which typically occur in packet based networks. In the E-model, impairment values are assigned to a number of independent parameters, which are then combined to give a transmission rating factor R as follows:

$$R = R_o - I_s - I_d - I_e + A$$

R_o represents in principle the basic signal-to-noise ratio, including noise sources such as circuit noise and room noise.

I_s is a combination of all impairments which occur more or less simultaneously with the voice signal. This includes loudness, sidetone, and quantizing distortion from analogue/digital conversions.

I_d represents the impairments caused by delay, which include Talker and Listener echo, and end to end delay.

I_e represents impairments caused by low bit rate codecs.

A is the expectation factor which allows for compensation of impairment factors when there are other advantages of access to the user, such as mobility.

- *Some parameters particularly receive and send loudness ratings impact on more than one impairment factor.*
- *Some factors are determined in terminal equipment. For example in digital networks which are in themselves lossless Loudness ratings are determined entirely by terminal equipment (phone) design. Other factors such as delay. are partly determined in terminal*

equipment design, partly determined in network design, and in packet networks, could vary according to network loading.

(2) This Specification details the measurements required to calculate the system performance according to the E-model. For the purposes of Telepermitting, these measurements are made on a minimal network (usually only two elements). While there are limits on most parameters beyond which a Telepermit will not be granted, the fact that a Telepermit is granted does not always guarantee satisfactory performance for all call types. In addition the quality of calls originating from a private network, is also dependent on:

- The terminating network (cellular, private VoP, direct analogue phone)
- Intermediate networks (e.g. international circuits using low bit-rate codecs).

(3) The design of any private network may be outside the direct control of the Telepermit holder, especially as regards which of the various options for speech encoding are used, the design of the network and the actual level and nature of traffic to be carried. Notwithstanding, the aim of this Specification is to get some basic equipment parameters correct which are under Telepermit holder control, then require the network designer or customer who actually connects the private network to the public network to be held responsible for its effective operation. This is the concept behind testing pairs of equipment without an intervening (and highly variable) network.

4.3

Transmission Levels and Loss Plan

This part of the specification outlines the requirements for transmission levels in a private voice network which is connected as customer equipment to the Telecom PSTN/ISDN. The transmission plan is designed to allow good performance in an any to any call scenario, including the mixing of analogue and digital phones and interfaces.

4.3.1

Design Objectives

(1) Proposed pads and levels are optimised for the long-term “all-digital” situation. Ultimately, the circuit-switched public network is likely to be replaced by an IP network which may directly connect into the private IP network with no FXO function.

(2) Network planning and digital terminal design for voice functionality shall comply with the ITU Overall Loudness Rating objectives of 10 dB, with SLR of +8 dB, RLR of +2 dB and no circuit losses.

(3) It is recognised that most traffic on a private network is usually “extension to extension”, whether the terminals are all digital or mixed analogue and digital. As such, the FXS pad values are optimised for this situation and set at “standard values” for use in all circumstances.

- *Analogue terminal loudness ratings incorporate allowances for the traffic weighted mean trunk loss. Ref Figs 4.3.3 and 4.4.4.*

(4) The level/loss plan recognises that digital trunks should always be used between the digital PSTN and the private IP network. In this case, the zero level point is simply extended from the PSTN into the private IP network, with no pads or gains in the interface.

(5) In the event that analogue trunks are the only option available. The default FXO settings of Fig 4.3.3 are gains to compensate for the T and R pads used in the PSTN. This means that private IP networks interfacing with the PSTN via analogue trunks suffer a transmission level loss relative to the optimum. This loss would be exacerbated in cases where long analogue trunks have to be used. While the FXO gains may be adjusted to compensate for analogue trunk loss in such cases, it is unlikely that long analogue trunks will be encountered.

(6) Loss values appear in the impairment calculations for most of the components which determine the overall R-value in the E-model. It is therefore highly desirable that the losses are set as close as possible to the optimum values. In most modern equipment these are software settings, and as such there is no additional cost in implementing the correct settings.

(7) Echo cancellation shall be incorporated in all interfaces to the PSTN where there is any likelihood of the delay in the private network exceeding 15 ms.

This would be always required in a VoIP system but not in a circuit switched PABX or keyphone system.

4.3.2 Testing

All level measurements shall be performed with G.711 A-law codecs utilised. Performance using other codecs cannot be measured using standard techniques, and in the interim, the performance of non-waveform codecs should be determined by subjective comparison. Any echo cancellers shall be turned on, and any silence suppression processes should be turned off.

4.3.3 Analogue FXS, Analogue FXO

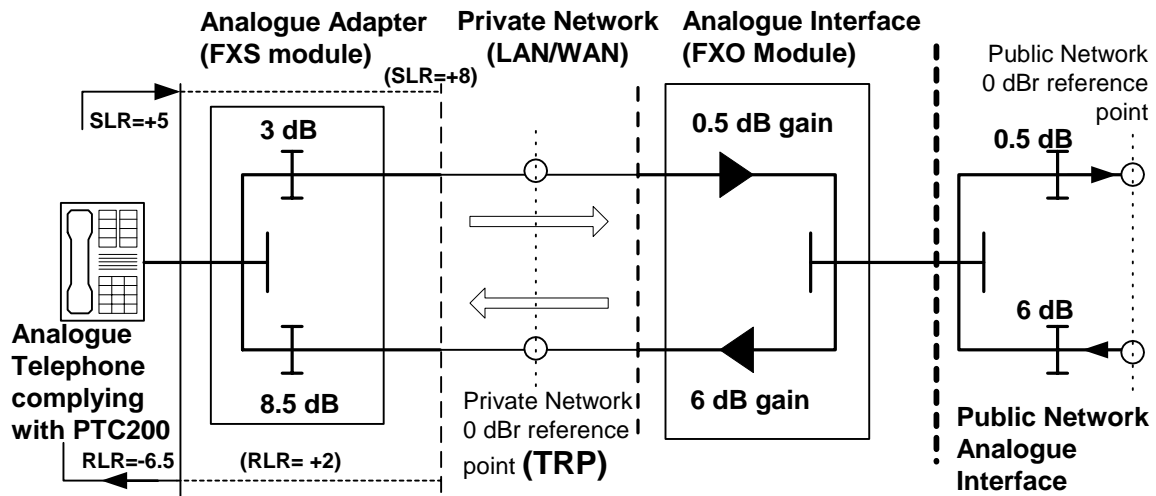

Figure 4.3.3 Standard PTC200 phone port to analogue trunk

4.3.3.1

FXS Loss Plan

- Loss from FXS Analogue port to TRP: 2.5 to 3.5 dB, **Objective: 3 dB**
- Loss from TRP to FXS Analogue port: 8.0 to 9.0 dB, **Objective : 8.5 dB**

4.3.3.2

FXO Loss Plan

- Loss from TRP to FXO Analogue trunk: 0 dB to -1 dB, **Objective: -0.5 dB**
- Loss from FXO Analogue trunk to TRP: -5.5 dB to -6.5 dB, **Objective -6 dB**

- The losses/gains shall be measured at 1000Hz
- If the losses are added up to the FXO 2-wire network interface, SLR = +7.5 and RLR = -4. These values are 2.5 dB higher (quieter) than the objective loudness ratings for an analogue phone connected at the same point. This is due to the fact that an analogue phone has 2.5 dB of extra gain to overcome the loss in a 2-wire access line. In an FXO - FXS situation it is generally not possible to recover this loss without the risk of the system becoming unstable.
- Note: -ve losses are gains

4.3.3.3

Network Loss

The allowable range for each loss/gain element is the objective +/- 0.5 dB. However this range is large enough that if the wrong extremes are implemented instability could arise. Therefore the values implemented shall be such that the end to end loss shall be as follows:

- (a) Loss from FXS port to FXO port: 2 to 3 dB, **Objective: 2.5 dB**
- (b) Loss from FXO port to FXS port: 2 to 3 dB, **Objective 2.5 dB**

4.3.4 Analogue FXS, Digital FXD

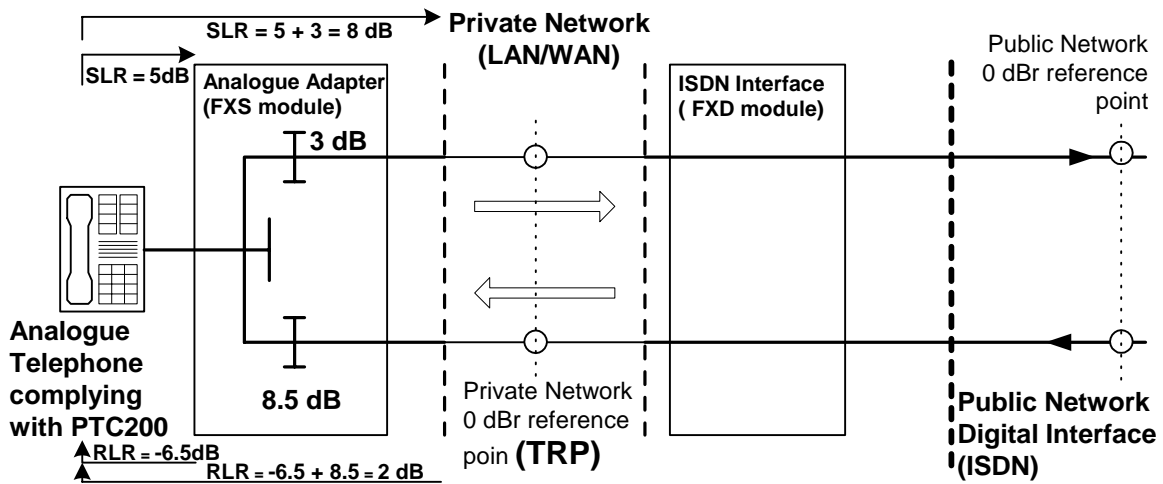

Figure 4.3.4 Standard PTC200 phone port to digital (ISDN) trunk

4.3.4.1

FXS Loss Plan

- Loss from FXS Analogue port to TRP: 2.5 to 3.5 dB, **Objective: 3 dB**
- Loss from TRP to FXS Analogue port: 8 to 9 dB, **Objective : 8.5 dB**

4.3.4.2

FXD Loss Plan

- Loss from TRP to FXD Digital (ISDN) trunk: 0.5 dB to -0.5 dB, **Objective: 0 dB***
- Loss from FXD Digital (ISDN) trunk to TRP: 0.5 dB to -0.5 dB, **Objective 0 dB***

- The losses/gains shall be measured at 1000Hz
- The 3dB and 8.5dB losses shown in the FXS module each include 2.5 dB loss which represents the 2-wire analogue loss in the cable between the FXS module and the analogue phone. If this line is likely to be long in practice, the FXS PAD values may be reduced to 0.5dB and 6dB respectively.
- Note: -ve losses are gains

4.3.5 Digital Phone to analogue FXO

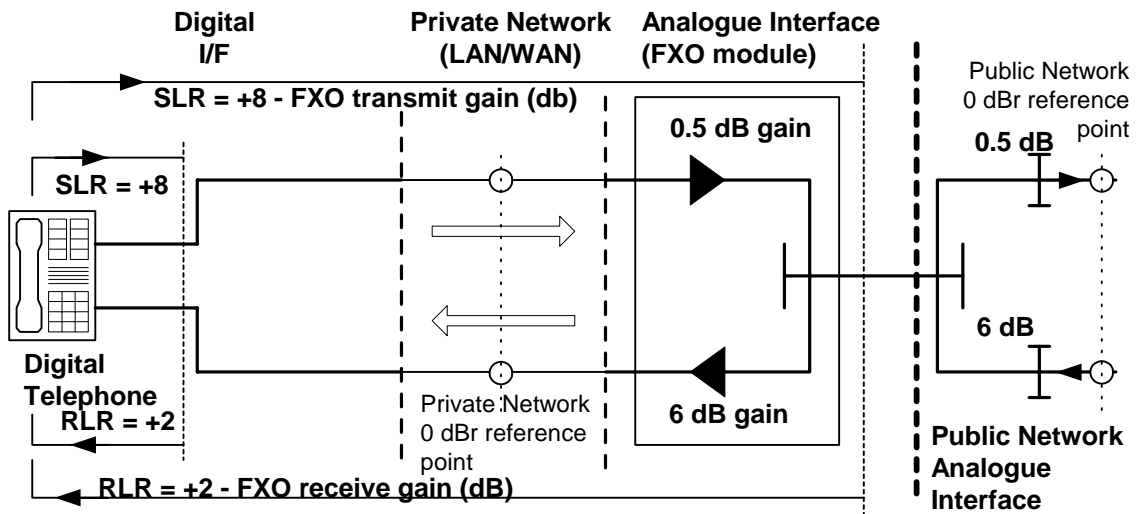

Figure 4.3.5 Digital Phone connected via analogue FXO

4.3.5.1

Digital Phone Loudness Rating

(a) SLR to TRP: +5 dB to + 11 dB, **Objective: +8 dB**

(a) RLR to TRP: -1 dB to + 5 dB, **Objective: +2 dB**

4.3.5.2

FXO Loss Plan

(a) Loss from TRP to FXO Analogue trunk: 0 dB to -1 dB,
Objective: -0.5 dB

(b) Loss from FXO Analogue trunk to TRP: -5.5 dB to -6.5 dB,
Objective -6 dB

- The losses/gains shall be measured at 1000Hz
- The variation of gain/loss shall be not more than +/- 0.5dB of the 1000 Hz value across the frequency band 300 to 3400 Hz
- If the losses are added up to the FXO 2-wire network interface, $SLR = +7.5$ and $RLR = +4$. These values are 2.5 dB higher (quieter) than the objective loudness ratings for an analogue phone connected at the same point. This is due to the fact that an analogue phone has 2.5 dB of extra gain to overcome the loss in a 2-wire access line. While it would be possible to add some additional gain This would lead to the possibility of instability if an FXS module were connected to the private network 0 dBr point. As with the analogue FXO connection shown in Fig 2.3.3, this illustrates the inherent problems with using 2-wire analogue connections between a private network and the public network.

4.3.6 Digital Phone to digital (ISDN) trunk (FXD)

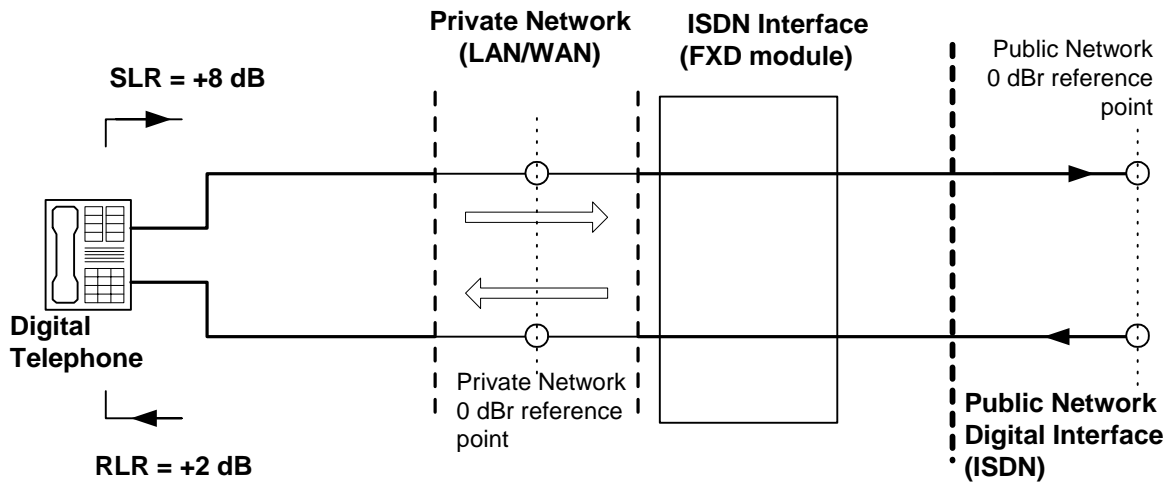

Figure 4.3.6 Digital phone connected via digital FXD

4.3.6.1

Digital Phone Loudness Ratings

- (a) Send Loudness Rating (SLR): +10 dB to +6 dB, **Objective: +8 dB**
- (b) Receive Loudness Rating (RLR): +4 dB to 0 dB (-8 dB with volume control), **Objective: +2 dB**

4.3.6.2

FXD

- (a) Loss from TRP to FXD Digital (ISDN) trunk: 0.5 dB to -0.5 dB, **Objective: 0 dB**
- (b) Loss from FXD Digital (ISDN) trunk to TRP: 0.5 dB to -0.5 dB, **Objective 0 dB**

- *Digital phone in this context is any phone other than a Telepermitted analogue phone complying with PTC200 which would connect to a Telepermitted FXS module.*
- *From a transmission point of view the digital phone may in fact be a system dependent analogue phone AND its associated FXS function. That is, the various gains/losses may be distributed between the phone and the FXS however the designer chooses, provided the SLR and RLR at the 0 dBr reference point are +8 dB and +2 dB respectively. It is assumed that the private network 0 dBr point is digital, although it could be analogue. However, it is unlikely that this would be the case.*

4.3.7 Voice Mail/ IVR System Analogue Network Interface

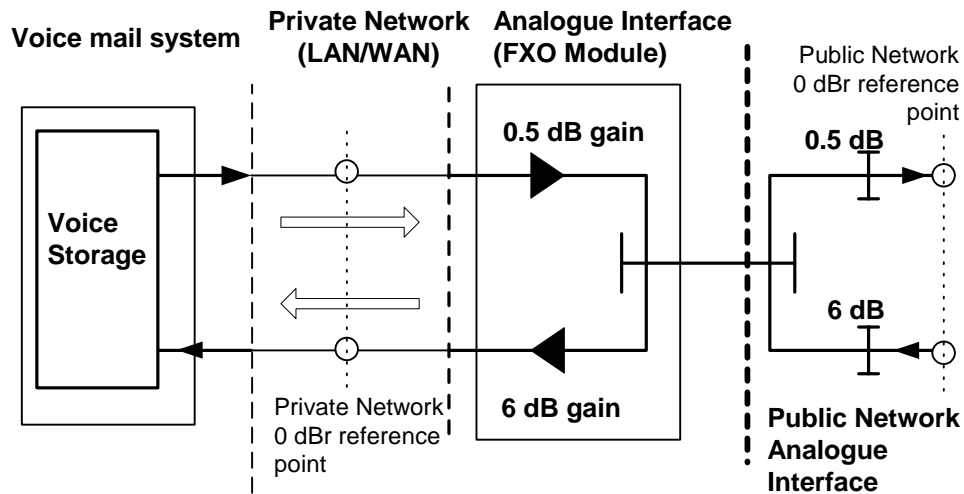

Figure 4.3.7 Voice Mail/ IVR System Analogue Network Interface

4.3.8 Voice Mail/ IVR System Digital Network Interface

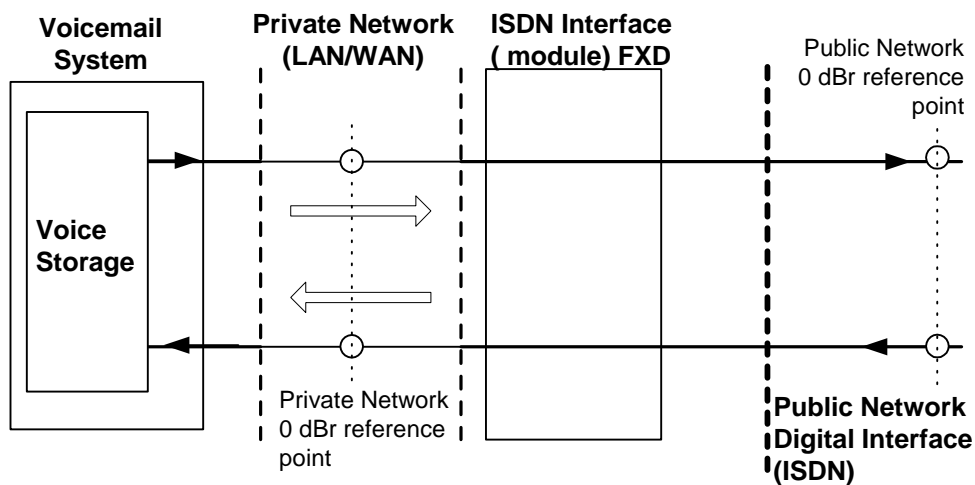

Figure 4.3.8 Voice mail system with digital network interface

Voice mail systems connected to private networks shall retransmit stored messages at the same level they were received at.

4.3.9 Tie lines

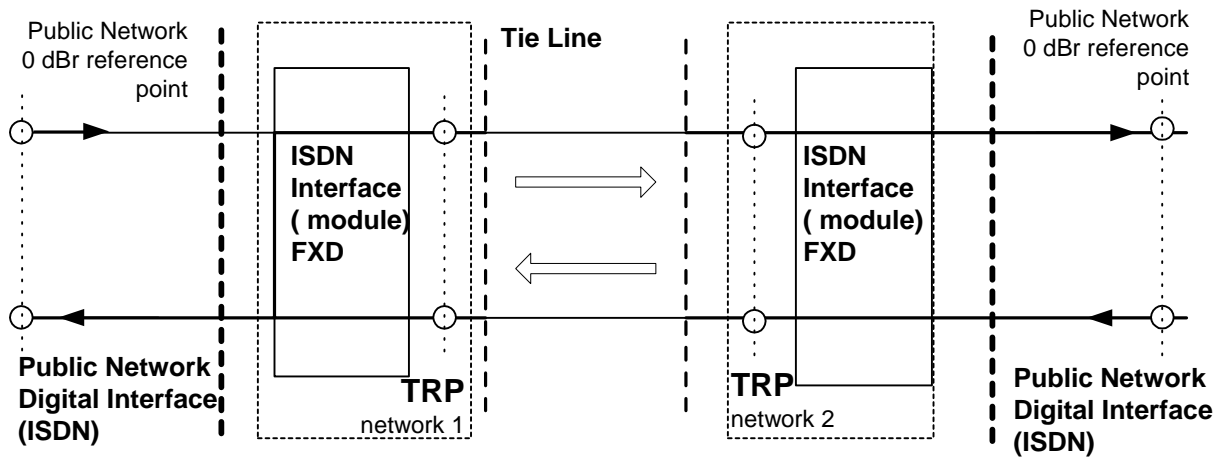

Figure 4.3.9: Two private networks connected by a tie line

Tie lines shall connect at the 0 dBr Transmission Reference Point (TRP) in each respective network.

Figure 4.3.9 shows two networks with digital (ISDN) FXD interfaces, connected by a tie line. The FXD interfaces both have 0 loss in the send and receive paths. If the FXD interfaces were analogue, the tie line is similarly connected at the 0 dBr TRP. The analogue FXD would have the same gain settings as shown in the previous examples.

4.3.10

Additional gain

To overcome losses in access cable between PSTN and Analogue FXO module, additional gain of up to 3 dB may be added symmetrically in each direction in the FXO module. This is subject to the stability criteria of PTC 200 clause 4.12.

4.4

Codec Distortion

Impairments due to codec distortion are given in Table 4.3.8 for standard codec processes. If other codec types are to be used, the Impairment factors shall be calculated as per ITU-T Recommendation G.113. All testing shall be performed using G.711 codecs. In addition, all codecs which can be invoked, shall be listed.

Codec type	Reference	Operating rate kbit/s	<i>le</i> value
PCM	G.711	64	0
ADPCM	G.726, G.727	40	2
	G.721(1988), G.726, G.727	32	7
	G.726, G.727	24	25
	G.726, G.727	16	50
LD-CELP	G.728	16	7
		12.8	20
CS-ACELP	G.729	8	10
	G.729-A + VAD	8	11
VSELP	IS-54	8	20
ACELP	IS-641	7.4	10
QCELP	IS-96a	8	21
RCELP	IS-127	8	6
VSELP	Japanese PDC	6.7	24
RPE-LTP	GSM 06.10, Full-rate	13	20
VSELP	GSM 06.20, Half-rate	5.6	23
ACELP	GSM 06.60, Enhanced Full Rate	12.2	5
ACELP	G.723.1	5.3	19
MP-MLQ	G.723.1	6.3	15

Table 4.4 Impairment factors for some common codecs

4.5

Delay

Delays of more than about 150ms in an end to end call begin to affect ease of conversation even in the absence of echo. Delays exceeding 400 ms are considered unacceptable by ITU (ITU-T Rec. G.114) but it is acknowledged that this will be exceeded in some exceptional cases, for example a 2-hop satellite link to a remote Pacific island.

Delays on circuit based connections:

- National (NZ) calls up to around 15 ms
- NZ-UK cable only \approx 150 ms
- NZ-UK cable/satellite \approx 300 ms (satellite propagation delay is 260 ms).
- Mobile systems such as GSM and CDMA introduce around 100 ms of additional delay on calls to the PSTN.
- Low bit rate encoding and digital processes in packet based systems tend to add significant delay.
- Further information on delay can be found in ITU-T recommendation G.114 (05/00) "One-way transmission time".

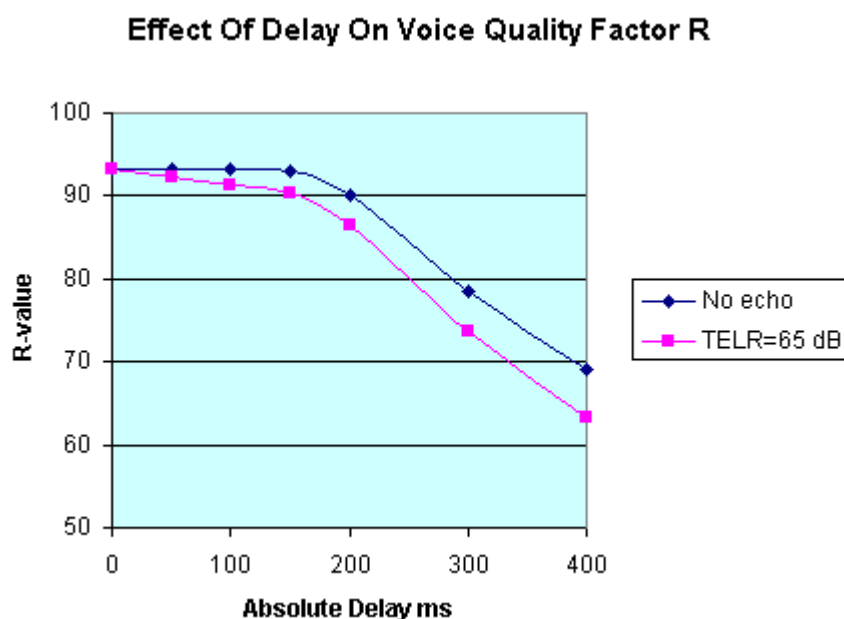

Figure 4.5.1 Effect of absolute delay in the absence of echo

- E-Model default values assumed for all other transmission input parameters.
- "No echo" curve assumes the use of a perfect echo canceller, i.e. no residual echo.
- Networks involving 2-wire/4-wire hybrids with echo cancellers fitted will still have a finite but high echo path loss.
- "TELR=65 dB" curve is for a real echo canceller which results in a total echo path loss of 65dB.

- End-to-end delay below 150ms has minimal effect on voice quality.
- Connections traversing multiple private and/or public networks involving one or more VoP systems may experience significant degradation if absolute delay and equipment impairments are not adequately controlled. This means that certain high delay routing combinations should be avoided.

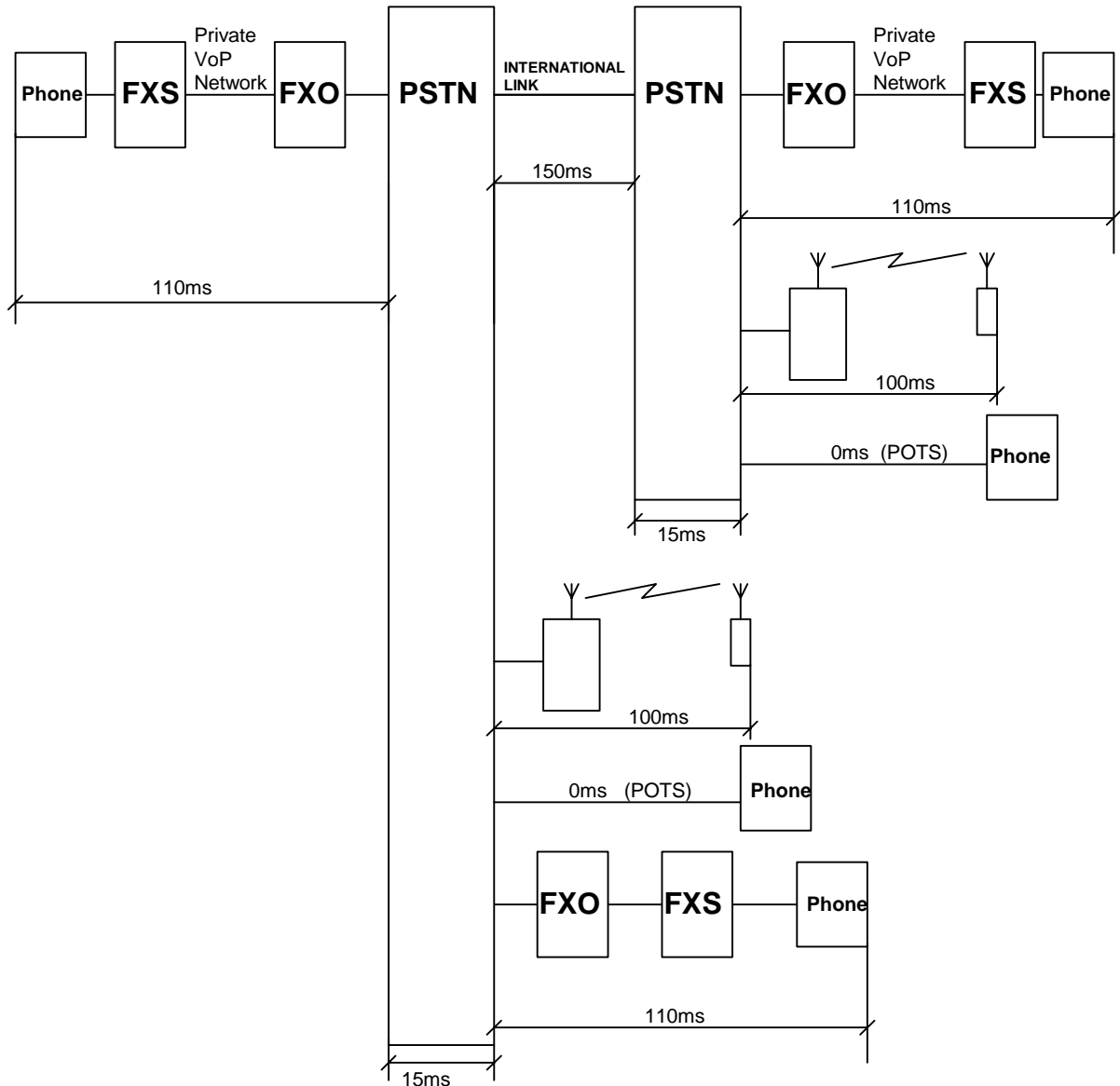

Figure 4.5.2 Block diagram showing typical delays in a number of call scenarios

- The 110ms delay shown against the VoP private network, is the maximum allowed for the delay within the private network where the call is an international call (e.g. NZ to UK) and the call is initiated and terminated on

a private VoP network, with the overall end to end delay being 400ms. Any other call combination will have less overall delay.

- In an all packet network, the FXO functions and any delays associated with them disappear, but the delays within the national network are likely to increase.

4.6

Noise

4.7

Echo

Where the mean one way propagation time exceeds 15ms echo cancellers shall be deployed. VoP and wireless technologies are likely to have inherent delays exceeding 15ms and would be expected to have echo cancellers fitted. Assuming echo cancellers are fitted, values of 65dB and 110dB are used for TELR and WEPL respectively in calculating the delay impairment factor I_d .

- *Ref ITU-T Recommendation G.107*

5.0

FXS Requirements

5.1

General

This section covers the requirements for a standalone FXS unit with analogue ports for connection to a PTC200 series Telepermitted phone. Where an FXS unit is intended for connection to PTC220 and PTC207 series proprietary (system dependent) phones, the phone and the FXS are tested together as a system dependent phone.

5.1.1

Test Configuration

The Test Laboratory shall document in the form of a block schematic, the configuration used for testing this section. This shall include the make and model of the FXO/D or Trunk interface used to complete some of the tests, and state where the TRP is located.

- *The TRP would normally be at the ethernet interface to the FXS, or in the case of a circuit switched PBX at the centre of the switch block.*
- *Examples of the block schematic are given in the test setups in Appendix 1 of this specification.*

5.1.2

Configuration Details

Actual setup configurations shall be recorded in the test report for all test results in this section. At least one FXS configuration must be able to achieve compliance for all parts of this specification.

5.2

Electrical Safety

The unit shall meet the requirements of AS/NZS 60950. This includes the following FXS components:

- (a) Power Supply
- (b) LAN/WAN port(s) isolation to TNV
- (c) 2-wire analogue port, isolation to TNV
- (d) Ringing feed to meet TNV definition. See clause 5.6.2(b) of this Specification.

- *The voltages used for ringing are in the LV range, but if other conditions are met such as duty cycle and source impedance, the ringing signal can be classified in the less dangerous TNV category.*

5.3

Transmission

5.3.1

Loss Plan

- (a) Loss from FXS Analogue port to TRP: 2.5 to 3.5 dB, **Objective: 3 dB**
- (b) Loss from TRP to FXS Analogue port: 8 to 9 dB, **Objective : 8.5 dB**

- *PTC220 clause 4.3.3.1 (4.3.4.1)*
- (c) Where FXS equipment has more than one port the loss between ports shall be 11 to 12 dB in both directions, Objective 11.5 dB
- *The above measurements to be taken at 1000Hz with a send level of -10 dBm0.*

5.3.2

Attenuation Frequency Distortion

The loss distortion with frequency between the two wire port and the TRP and the TRP and the 2-wire port shall be within the following limits, using an input level of -10 dBm0.

Frequency (Hz)	Loss relative to the loss at 1000Hz (dB)
300 - 400	+1, -0.3
400 - 600	+0.75, -0.3
600 - 2000	+0.35, -0.3
2000 - 2400	+0.45, -0.3
2400 - 3000	+0.7, -0.3
3000 - 3400	+1.7, -0.3

- *Reference ITU Recommendation Q.552*

5.3.3

Variation of Gain with input level

With a 1000 Hz sinewave signal applied to either the 2-wire port or the 4-wire 0dBr point at a level between -55 dBm0 and +3 dBm0, the gain of that signal relative to the gain of a signal at an input level of -10 dBm0, shall be within the following limits:

Input level (dBm0)	Gain Variation (dB)
-55 to -50	+/- 1.6
-50 to -40	+/- 0.6
-40 to +3	+/- 0.3

- *ITU-T Recommendation Q.552 clause 3.1.1.4*

5.3.4

Port Impedance

There are two impedances associated with an FXS port. Firstly there is the input impedance of the port, and secondly the balance impedance. Both of these impedances are important for overall performance, with impedance mismatches causing, high sidetone in the telephone, low levels of speech, echo, and in the worst case instability.

5.3.4.1

Port Input Impedance

The nominal input impedance used by Telecom is a 370 ohm resistor in series with a parallel combination of a 620 ohm resistor and a 310 nanofarad capacitor (known as BT3). For Telepermit compliance this is measured as a Return Loss against BT3, at the following frequencies:

200, 250, 315, 400, 500, 630, 800, 1000, 1250, 1600, 2000, 3150, 4000 Hz

- (a) The Return Loss shall not be less than 12dB at any of the above frequencies.
 - (b) The Echo Return Loss shall be not less than 14 dB.
- *The ELR shall be calculated according to the method given in ITU-T Recommendation G.122*

5.3.4.2

Terminal Balance Return Loss (TBRL)

Using the test method described in Appendix 1 of this specification, the TBRL shall exceed the limits shown in the figure below.

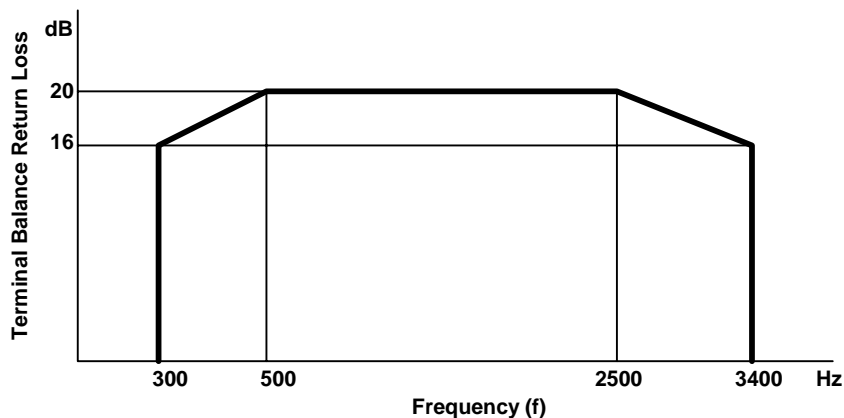

Figure 5.3.4.2 Terminal Balance Return Loss (TBRL) Requirement

- *reference ITU-T Recommendation Q.552 clause 3.1.8*

5.3.4.3

Crosstalk between Ports

Where FXS equipment has more than one analogue port there shall be a minimum of 50 dB isolation between individual ports over the range 300 - 3400 Hz. This shall apply to ports when in an off-hook condition.

5.3.4.4

Noise

- (1) With the analogue port terminated in 600 ohms (off-hook with speech path open but quiet) the noise shall be less than -65 dBmP
- (2) With the analogue port terminated in 10 kohms (on-hook) the noise shall be less than -65 dBmP
- (3) The noise in any 3kHz bandwidth above 4kHz shall be below lines joining the points given in table 5.3.4.4.

FREQUENCY (kHz)	POWER SPECTRAL DENSITY (dBm)
4.0	-40
10.0	-40
20.0	-50
50.0	-70
>50.0 & <100.0	-70
>100.0 & <10 MHz	-50

Table 5.3.4.4 limits for noise above 4kHz on FXS port

5.3.4.5

Impedance balance ratio to earth

(1) FXS 2-wire ports shall have an impedance balance ratio to earth of not less than 40 dB over the frequency range 200 - 4000 Hz when tested as shown in Fig. 5.3.4.5.

- *It is strongly recommended that the Impedance balance ration to earth be not less than 60 dB over the frequency range 200 - 1000 Hz.*

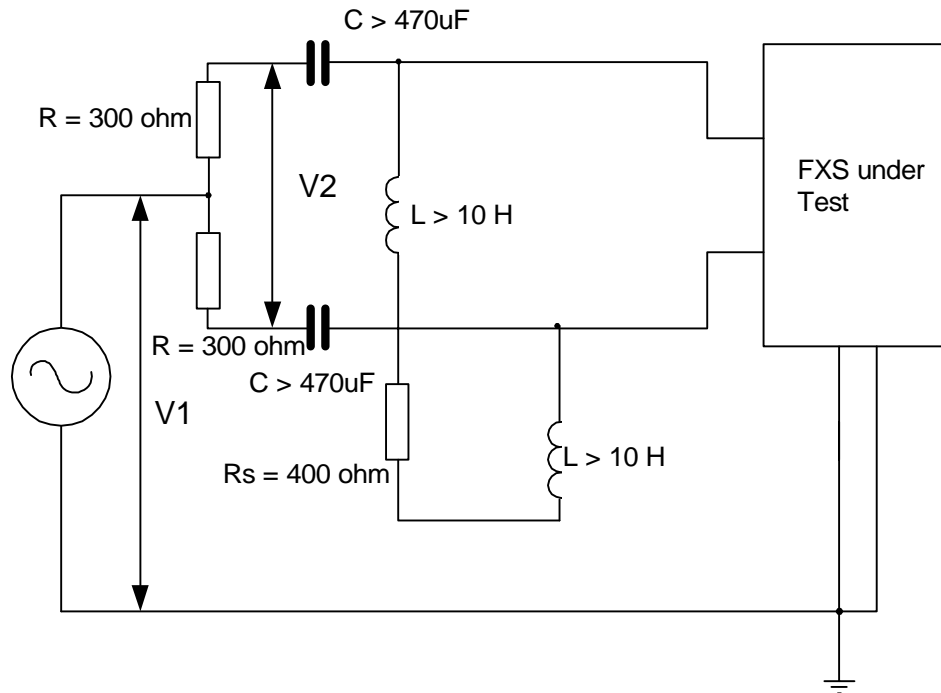

NOTES:

1. Resistors 'R' to be matched to within 0.1%
2. Rs to include resistance of the two inductors
3. Capacitors 'C' to be matched to within 10%
4. Power earth & signal earth shall be connected together for duration of test
5. Balance Ratio to Earth = $20 \log_{10} V1/V2$ dB

Figure 5.3.4.5 MEASUREMENT OF IMPEDANCE BALANCE RATIO TO EARTH

5.3.4.6

Delay

(1) Delay shall be measured between the network connection and the analogue port in both directions for the following configurations:

- (a) Each different codec type supported by the product
- (b) With VAD turned on and off
- (c) With Jitter buffer set to minimum and maximum lengths.

(2) The maximum delay acceptable for calls to other networks is 50ms. For Telepermitting purposes, this must be achievable on at least one of the above configurations. Where there are configurations which cannot meet this requirement, the instructions must be included warning that these configurations must not be used for calls which leave the private network.

- *This allows for 50 ms delay in the FXO/FXD and 10ms delay in the private network itself to meet the 110 ms total shown in Fig 4.3.9.2. In practice the delays in the FXS and FXO/D should be less than 50 ms to allow switching/routing within the private network.*

5.3.4.7

Codec Type

All FXS equipment shall include a G.711 codec. Other codecs may also be used, but cannot be tested using conventional test techniques. A list of all codecs used and the method of implementing them shall be provided. This includes information as to whether the codec is fixed as part of the initial system set-up, or is selected dynamically on a call by call basis depending on the call destination or other parameters.

5.3.4.8

Packet Format

Where the network side of the FXS equipment uses packet format, the following details shall be provided:

- (1) Minimum and maximum configurable packet lengths (octets).
- (2) Packet header length (octets)
- (3) Network transmission speed (bits/sec)

5.3.4.9

Echo

Where the mean one way propagation time exceeds 15ms echo cancellers should be deployed. VoP and wireless technologies are likely to have inherent delays exceeding 15ms and would be expected to have echo cancellers fitted. Assuming echo cancellers are fitted, values of 65dB and 110dB are used for TELR and WEPL respectively in calculating the delay impairment factor I_d .

The configuration and parameters of an echo canceller shall be stated if used in the FXS.

5.4

Signalling

5.4.1

DTMF Receiver Characteristics

FSX ports shall include a DTMF receiver capable of responding to DTMF signals in the following ranges:-

- (a) Any receive level between -5 dBm and -30 dBm.
- (b) High frequency pre-emphasis of between 0 and 3 dB.
- (c) DTMF frequencies within $\pm 1.8\%$ of the nominal values (ref. PTC200 clause 5.2.1(1)).
- (d) The receiver shall recognise any valid DTMF signal that is present for a minimum of 55 ms, as long as it is preceded by a continuous pause of 55 ms.

5.5

d.c. characteristics

(1) FXS ports for connection to other items of CPE shall provide a d.c. line feed.

(2) There are two alternative recommended methods of locally powered line feed as follows:-

(a) 50 V d.c., fed via a constant impedance source (commonly 400 ohm), with current usually limited at some value below 80 mA.

(b) Constant or restricted current in the range 18 mA to 45 mA.

- *The line feed is normally applied as negative battery (relative to earth) on one wire and earth on the other. This is not however mandatory for this application. CPE devices are required to be polarity insensitive so it is not necessary to specify a particular polarity for line feed.*

(3) The d.c. feed shall be capable of supplying not less than 20 mA into a 450 ohm load.

(4) The User Instructions shall clearly state any restrictions on the loop resistance of line between the series device and the CPE connected to it such that sufficient current can be drawn to establish the off-hook condition.

- *For the small number of cases involving devices which are designed to be installed remote from the terminal CPE, consideration must be given to the Telecom local line limits, i.e. the limit will apply to the total of the length of line between exchange and device plus the length of line between the device and the terminal CPE. For such devices, each application will be considered on its individual merits.*

(5) Ripple components shall not exceed 2 mV psophometric measured into loads of 1000 ohm and 50 ohm.

(6) The line feed shall be such that the equipment recognises the CPE state as follows:-

(a) Off-hook, when the d.c. feed current is greater than 15 mA for a period not less than 10 ms for a load of 1000 ohm.

- *When ringing is being sent to CPE, the ring trip d.c. would normally have to be maintained for 40 ms or more.*

(b) On-hook, when the d.c. feed current is less than 5 mA for a period not less than 1000 ms for a load of 10 kohm.

(7) Many CPE devices have features such as 'last number redial' or 'memory dial' which depend on a small on-hook line current for the maintenance of memory information. The line feed provided by FXS devices shall either:-

(a) provide a d.c. power source capable of supplying a continuous on-hook current of at least 150 μA in order to maintain such memories, or,

(b) have a clear warning inserted in the User Instructions advising users that such terminal devices connected to the FXS may lose their memory functions.

(8) The User Instructions shall give some indication of the maximum number of parallel CPE devices that can satisfactorily be operated on one port. This number of devices, however, is subject to the limitations of clause 5.6.2 (g) which means the maximum will never exceed 4 or 5.

- *Individual items of CPE are normally restricted to drawing no more than 120 μA from the line in the on-hook condition. This limit may be used as a means of establishing the number of items likely to operate.*

5.6

Ringling

5.6.1

Terminal equipment (or extension) ports

(1) FXS equipment shall not connect ringling to any terminal port which is in the off-hook condition. Similarly, after ringling has been applied to a port, it shall be disconnected within 100 ms of detection of an off-hook condition.

(2) All terminal equipment ports on FXS equipment shall support both 2-wire and 3-wire connection or carry a suitable warning if 3-wire connection not supported.

5.6.2

Locally generated ringling characteristics

The local ringling source shall satisfy the following requirements:-

(a) The ringling supply shall comply with the electrical safety requirements of AS/NZS 60950.

(b) The ringling voltage and duration shall comply with the TNV requirements of AS/NZS 60950, Section 6.

(c) Ringling shall be connected to the port as a loop connection, i.e. one terminal of the ringer supply connected to one wire of the port with the other wire serving as a ring return path to the other side of the ringer supply.

(d) The ringling frequency shall be 25 ± 1 Hz.

(e) The crest factor of the ringling waveform shall be checked and should preferably be between 1.2 and 1.6.

- *The crest factor is defined as the ratio of the peak to r.m.s. voltage, and this equates to a value of 1.414 for a pure sine wave.*

- *Some telephone devices tend to be subject to premature ring trip when subjected to square wave ringing signals.*

(f) If the crest factor is outside the limits stated in (e) above, or the ringing frequency outside the limits in clause (d), then the following warning notice shall be included in the User Instructions:-

"Difficulties may be experienced with this device ringing some types of telephone connected to it. If this problem occurs, it should be referred to the equipment installer. The matter should NOT be referred to Telecom Faults Service"

(g) The ringing output shall be rated for the aggregated RN of the CPE which will respond reliably to ringing. This is defined as the number of $0.5 \mu\text{F} + 16 \text{ kohm}$ loads across which the ringing source can maintain 107 Vpp , divided by 2.

(h) The application of a load of twice the RN rating determined in (g) above, connected in parallel with a 10 kohm resistor, shall not cause ring trip.

- *Clause 5.5 (2)(a) describes off-hook ring trip conditions.*

(i) Ringing cadences used should preferably be in accordance with those stated in Technical Document TNA 102, clause 6.4 with a tolerance of $\pm 10 \%$. The preferred cadence is DA1.

- *Some CPE may only respond to DA1.*
- *This requirement relates particularly to use of terminating devices designed to respond to distinctive alert cadences.*

(j) If the ringing cadence used is not in accordance with TNA 102, the following warning notice shall be included in the User Instructions:-

"Devices designed to respond to particular ringing cadences may not respond when used with this equipment"

5.7

FXS port socket requirements

(1) The primary method of connection of Telepermitted terminal equipment is via a plug to BS 6312:1985, with the latch adjacent to plug pin 6. The plug mates with a standard BT socket. This arrangement applies to both 2-wire and 3-wire connection (see also TNA 102, clause 9.3).

- *The plug to BS 6312:1985 is commonly known as a "BT" plug. (2) (a) The socket/plug pin numbering is as follows:-*

Pin 1	not used
Pin 2	A-wire
Pin 3	earth (when provided)
Pin 4	ringer-wire (3-wire only)
Pin 5	B-wire
Pin 6	not used

(3) An acceptable alternative plug and socket arrangement for 2-wire connection in business premises is the 8-way modular connector specified in AS/NZS 3080, IEC 11801, IEC 603-7, and also in EIA/TIA-568 and EIA/TIA-570. The preferred pin-out designation is T568A, using pins 4 & 5 as shown in Technical Document TNA 102, Fig. 7.

- *This 8-way plug and socket is commonly known as "RJ45" in New Zealand. However, this is not strictly the correct designation.*

(4) Either BT plugs or 8-way modular plugs may be fitted on 2-wire connected CPE without the need for separate Telepermits. However, where the 8-way plug is fitted, this should be clearly shown on product packaging.

It is expected that FXS equipment with more than one or two ports is likely to be located in a central location and connected to the CPE via the building cabling.

5.8

Supplementary Services

5.8.1

Switch-hook Flash

PTC 200 specified CPE generates Switch hook flash of duration between 500 and 800 ms. FXS equipment which recognises SHF shall recognise breaks of 300 to 800 ms where the break is defined as a current of less than 5mA for a d.c. load of 10 kohm, and the off-hook condition either side of the break is defined as a current of 15 mA or greater for a load of 1000 ohm.

The FXS equipment shall send a suitable signal to the FXO or FXD, which in turn shall generated a suitably timed break (FXO) or a feature activation element (ISDN FXD).

This functionality shall be checked with a suitable FXO/FXD.

5.8.2

Caller ID

If the FXS generates caller ID, it shall generate messages as described in TNA 102 sections 10 and 11.

The format of the number is Area Code + DN for calls from the PSTN (including local calls). If the call originates from numbers on the same private network, the number calling party number is displayed without an area code prefix.

5.8.3

Distinctive alert ringing

If an FXS implements distinctive alert ringing, the ringing cadences generated are as follows:

DA1 (400ms on, 200ms off, 400 ms on, 2000 ms off) repeated

DA2 (400 ms on, 2600 ms off) repeated

DA3 (400ms on, 200ms off, 400 ms on 200ms off, 400 ms on 1400 ms off) repeated

DA4 (400ms on, 800ms off, 400 ms on, 1400 ms off) repeated

- *DA1 is the standard cadence*
- *DA2 and DA 3 are currently used for CENTREX only*
- *DA4 is used for FaxAbility service, and is only available on analogue PSTN connections*

5.8.4

Fax/Voice band modem transport

If the FXS equipment is connected to the FXO/FXD by either low bit rate transmission, or via packets such as IP, voiceband data such as fax or V.92 modems may not operate at full speed, or may not operate at all. If special measures are taken to enable voiceband data to be transported these shall be noted. See clause 5.9.4 for functional test.

- *The normal method of dealing with voiceband data is to demodulate the analogue signals, transport them as data, and re-modulate them at the FXS/FXD for passing onto the PSTN/ISDN.*

5.9

Functional requirements

5.9.1

General

This Section covers the functional requirements for FXS equipment. Many of these requirements depend on compatible FXO/FXD equipment, and tests shall be performed with such suitable equipment. Telepermits will be granted to FXS equipment subject to use with the FXO/FXD equipment with which it was tested or equipment with equivalent functionality. It is the responsibility of the Telepermit holder to ensure that suppliers and system integrators of FXS equipment are aware of suitable such equipment.

5.9.2

Call Set-up (outgoing call)

5.9.2.1

Pre-dial Supervisory Tone (Dial Tone)

- a) Dial tone shall be presented to the analogue interface within 500ms of the application of a d.c. loop of 1000 Ohm.
- b) The level shall be between -20dBm and -13dBm measured across a 600 ohm load.
- c) The frequency of the dial tone shall be recorded.
 - *The standard for Telecom is 400 Hz*

5.9.2.2

Signalling

When a number is dialled from a PTC 200 compliant phone connected to the analogue port, the correct number shall be dialled via the FXO/FXD network connection.

5.9.2.3

Call progress indicators

The following call progress indicators shall be presented to the analogue interface within five seconds. The cadences and frequencies and any other features of the indicators shall be recorded.

1. Ringing tone (as an indication that the called party phone is ringing)
 2. Busy Tone (as an indication that the called party is busy)
 3. Recorded Announcement (used to indicated a variety of conditions from the network)
 4. Disconnect tone (to indicate that the other party has hung up)
 5. NU (to indicate that the number dialled does not currently exist)
 6. Network congestion tone (to indicate that the network cannot complete the call at that time)
- *The tones used on the Telecom Network are detailed in TNA 102.*

5.9.2.4

Call connect

A bothway audio connection shall be established within 200ms of cessation of ringing tone.

5.9.2.5

Call clear

If a call is aborted during setup, the FXO/FXD shall clear down any network connection within 5 seconds.

5.9.2.6

Call in progress

1. Bothway audio connection shall be maintained until one or other party clears the call.
2. While call is in progress, DTMF tones received by the FXS equipment from CPE connected to the analogue port shall be forwarded to the PSTN/ISDN at the FXO/FXD.
3. While call is in progress, DTMF tones received by the FXO/FXD from the PSTN/ISDN shall be presented at the FXS analogue interface. Where the DTMF signals are generated in the FXS equipment, they shall meet the requirements given in section 6.4 of this specification, except for the level requirement which for this clause has a lower limit of -24 dBm.
 - *This requirement is for equipment which may be terminated on the FXS equipment and uses DTMF signalling for remote control.*
 - *Where G.711 codecs are employed, the DTMF can be carried in-band in both directions, but with some low bit rate codecs, it may be necessary to generate the DTMF at both the FXS analogue interface and the FXO/FXD network interface.*
4. A Switch hook flash generated by CPE connected to the analogue port of the FXS equipment shall meet the PTC200 limits when regenerated at the FXO/FXD interface.

5.9.2.7

Call Clear

5.9.2.7.1

Call Clear from CPE connected to analogue port of FXS

The FXO/FXD shall clear down the call at the interface to the PSTN/ISDN within 5 seconds of the CPE connected to the analogue port of the FXS equipment.

5.9.2.7.2

Call Clear from other party (from the PSTN/ISDN)

When the other party clears the call, some form of indication should be provided by the analogue port of the FXS equipment so that the user is aware that the call has terminated.

- *This clause is not mandatory, but desirable, particularly if voice activity detection is used, in which case there may be no indication at all that the call has been cleared.*

5.9.3

Incoming call (from PSTN/ISDN via gateway to CPE connected to analogue port of FXS equipment)

1. Ringing shall be presented at the analogue port of the FXS equipment within 5 seconds of the indication being sent to the FXO/FXD interface from the PSTN.
See clause 5.6 of this specification for details of ringing.

2. Ringing shall cease and a bothway audio transmission path shall be established within 100ms of a loop of up to 1000 ohms being applied at the analogue port of the FXS equipment.
3. If Caller ID is implemented, it shall conform to the specifications given in TNA 102 sections 9 and 11.

5.9.4

Voiceband Data

If the FSX makes special provision for carrying voiceband data, a fax or data call to a compatible modem (fax or data modem) on the PSTN, and receive a data call from a compatible modem on the PSTN.

6.0

FXO Requirements

6.1

General

This sections covers the requirements for a standalone FXO unit for interfacing a private voice network to an analogue PSTN line.

6.1.1

Test Configuration

The Test Laboratory shall document in the form of a block schematic, the configuration used for testing this section. This shall include the make and model of the FXS used to complete some of the tests, and state where the TRP is located.

- *The TRP would normally be at the ethernet interface to the FXO, or in the case of a circuit switched PBX at the centre of the switch block.*
- *Examples of the block schematic are given in the test setups in Appendix 1 of this specification.*

6.1.2

Configuration Details

Actual setup configurations shall be recorded in the test report for all test results in this section. At least one FXO configuration must be able to achieve compliance for all parts of this specification.

6.2

Electrical Safety

The unit shall meet the requirements of AS/NZS 60950. This includes the following FXO components:

- (a) Power Supply
- (b) LAN/WAN port(s) isolation to TNV3

6.3

Transmission

6.3.1

FXO Loss Plan

- (a) Loss from TRP to FXO Analogue trunk: 0 dB to -1 dB,
Objective: -0.5 dB
- (b) Loss from FXO Analogue trunk to TRP: -5.5 dB to -6.5 dB,
Objective -6 dB

- *PTC220 clause 4.3.3.2 (4.3.5.2)*

6.3.2

Attenuation Frequency Distortion

The loss distortion with frequency between the two wire port and the TRP and the TRP and the 2-wire port shall be within the following limits, using an input level of -10 dBm0.

Frequency (Hz)	Loss relative to the loss at 1000Hz (dB)
300 - 400	+1, -0.3
400 - 600	+0.75, -0.3
600 - 2000	+0.35, -0.3
2000 - 2400	+0.45, -0.3
2400 - 3000	+0.7, -0.3
3000 - 3400	+1.7, -0.3

- *Reference ITU Recommendation Q.552*

6.3.3

Variation of Gain with input level

With a 1000 Hz sinewave signal applied to either the 2-wire port or the 4-wire 0dBr point at a level between -55 dBm0 and +3 dBm0, the gain of that signal relative to the gain of a signal at an input level of -10 dBm0, shall be within the following limits:

Input level (dBm0)	Gain Variation (dB)
-55 to -50	+/- 1.6
-50 to -40	+/- 0.6
-40 to +3	+/- 0.3

- *ITU-T Recommendation Q.552 clause 3.1.1.4*

6.3.4

Port Impedance

There are two impedances associated with an FXO port. Firstly there is the input impedance of the port, and secondly the balance impedance. Both of these impedances are important for overall performance, with impedance mismatches causing, high sidetone in the telephone, low levels of speech, and echo.

6.3.4.1

Port Input Impedance

6.3.4.1.1

Off-hook Impedance

The nominal input impedance used by Telecom is a 370 ohm resistor in series with a parallel combination of a 620 ohm resistor and a 310 nanofarad capacitor (known as BT3). For Telepermit compliance this is measured as a Return Loss against BT3, at the following frequencies:

200, 250, 315, 400, 500, 630, 800, 1000, 1250, 1600, 2000, 3150, 4000 Hz

- (a) The Return Loss shall not be less than 12dB at any of the above frequencies.

(b) The Echo Return Loss shall be not less than 14 dB.

- *The Echo Return Loss shall be measured using the method described in ITU-T Rec G.122*

6.3.4.1.2

On-hook impedance

The on-hook impedance (including impedance of bridging equipment) of any device connected to a Telecom line shall be not less than 10 kohm for the frequency range 300 Hz to 3400 Hz when measured with 1 Vrms applied.

- *This requirement may be relaxed for certain devices where it is known that they will definitely not be connected in parallel with any other device.*

6.3.4.2

Terminal Balance Return Loss (TBRL)

ref ITU-T Recommendation Q.552 clause 3.1.8

Using the test method described in Appendix 1 of this specification, the TBRL measured as a return loss against BT3, shall exceed the limits shown in the figure below.

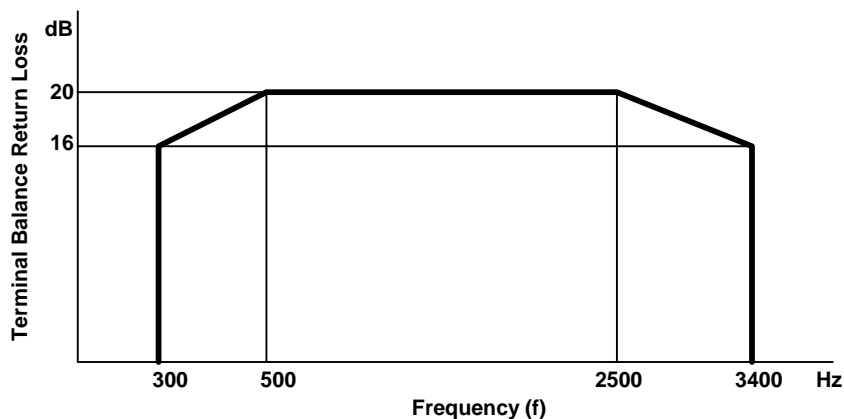

Figure 6.3.4.2 Terminal Balance Return Loss (TBRL) Requirement

6.3.4.3

Crosstalk between Ports

Where FXO equipment has more than one analogue port there shall be a minimum of 50 dB isolation between individual ports over the range 300 - 3400 Hz. This shall apply to both on-hook and off hook conditions.

6.3.4.4

Impedance balance ratio to earth

(1) Devices which have a direct or indirect connection to earth shall, for both on-hook and off-hook conditions, have an impedance balance ratio to earth of not less than 40 dB over the frequency range 200 - 4000 Hz when tested as shown in Fig. 6.3.4.4.

(2) It is strongly recommended that, in the off-hook condition, devices should also have an impedance balance ratio to earth of not less than 60 dB over the frequency range 200 - 1000 Hz.

(3) Equipment connected directly or indirectly to mains power supplies shall also comply with the requirements of this clause.

- *ELV plug packs will provide some capacitive coupling between earth and the ELV output leads, so may affect impedance balance to earth in some cases. Equipment shall therefore be tested while connected to a power supply of the type supplied to customers.*

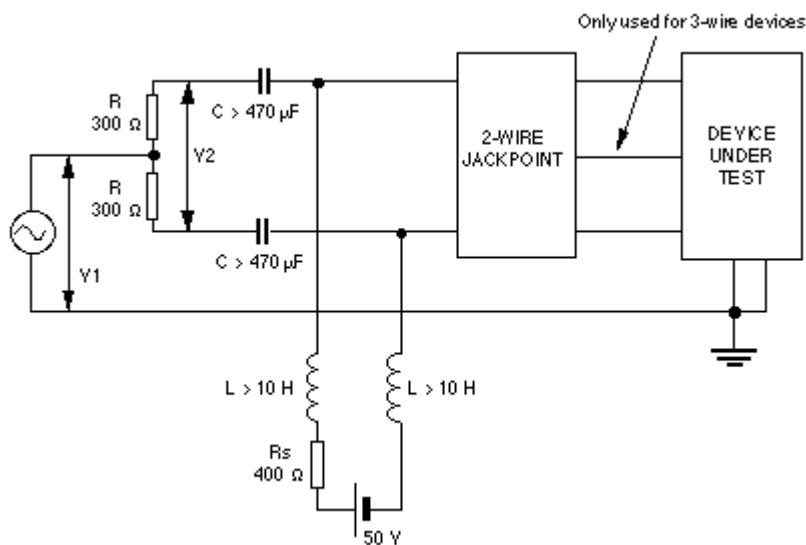

NOTES:

1. Resistors 'R' to be matched to within 0.1%
2. Capacitors 'C' to be matched to within 10%
3. Power earth & signal earth shall be connected together for duration of test
4. Balance Ratio to Earth = $20 \log_{10} V1/V2$ dB
5. Balance ratio to be determined with device in both 'on-hook' and 'off-hook' conditions.

Figure 6.3.4.4 MEASUREMENT OF IMPEDANCE BALANCE RATIO TO EARTH

6.3.4.5

Delay

(1) Delay shall be measured between the network connection and the analogue port in both directions for the following configurations:

- (a) Each different codec type supported by the product
- (b) With VAD turned on and off
- (c) With Jitter buffer set to minimum and maximum lengths.

(2) The maximum delay acceptable for calls to other networks is 50ms. For Telepermitting purposes, this must be achievable on at least one of the above

configurations. Where there are configurations which cannot meet this requirement, the instructions must be included warning that these configurations must not be used for calls which leave the private network.

- *This allows for 50 ms delay in the FXS or phone and 10ms delay in the private network itself to meet the 110 ms total shown in Fig 4.3.9.2. In practice the delays in the FXS/phone and FXO should be less than 50 ms to allow switching/routing within the private network.*

6.3.4.6

Codec Type

All FXO equipment shall have a G.711 codec. Other codecs may also be used, but cannot be tested using conventional test techniques. A list of all codecs used and the method of implementing them shall be provided. This includes information as to whether the codec is fixed as part of the initial system set-up, or is selected dynamically on a call by call basis depending on the call destination or other parameters.

6.3.4.7

Echo

(1) Where the mean one way propagation time exceeds 15ms echo cancellers should be deployed. VoP and wireless technologies are likely to have inherent delays exceeding 15ms and would be expected to have echo cancellers fitted. Assuming echo cancellers are fitted, values of 65dB and 110dB are used for TELR and WEPL respectively in calculating the delay impairment factor Id.

(2) The configuration and parameters of an echo canceller shall be stated if used in the FXO.

6.4

Signalling

6.4.1

Transmission of DTMF signalling

- *Reference CCITT Blue Book, Recommendation Q. 23.*

6.4.2

DTMF frequencies

(1) The allocation of DTMF signalling frequencies shall be as follows:-

Low Group (Hz)	High Group (Hz)			
	1209	1336	1477	1633
697	1	2	3	A
770	4	5	6	B
852	7	8	9	C
941	*	0	#	D

(2) Each transmitted frequency shall be within $\pm 1.5\%$ of the nominal frequency.

- (3) DTMF signalling devices shall support at least the 10 numeric digits plus '*' and '#' symbols.

- *The 'A', 'B', 'C' and 'D' are rarely used at the date of issue of this Specification.*

6.4.3

DTMF signalling requirements

- (1) For optimum performance, all transmitted DTMF frequencies shall comply with the requirements of this Specification at all line currents in the range 20 mA to full current.
- *Full current is defined as the current drawn by the FXO port when connected to a 50V + 400 Ohm feedbridge*
- (2) All devices shall satisfy the following requirements during the transmission of DTMF signalling:-
- (a) While DTMF signals are being transmitted during the setting-up of a call, the minimum return loss against BT3 shall be no less than 5 dB.
- *This relaxation does not apply to the transmission of DTMF signals following establishment of the call, e.g. signalling CPE to CPE.*
- (b) Each individual signalling tone of a burst, when measured against 600ohm on a zero length line, shall be at a power level between -4 dBm and -13 dBm.
- (c) For successful operation of DTMF signalling between customer premises, it is recommended that DTMF send levels be in the range -4 dBm to -10 dBm.
- (d) There shall be a pre-emphasis in the range 1 to 3 dB for the high frequency tone group relative to the low frequency group.
- (e) During signalling (call set-up phase for all devices):-
- (i) The individual power level of any extraneous frequency in the range 300 Hz to 5 kHz during signalling shall be at least 20 dB below that of the signalling frequency with the lowest level.
- (ii) The one minute mean power level in any 3 kHz bandwidth contained wholly above 5 kHz shall be at least 20 dB below that of the signalling frequency with the lowest level.
- *"Noise" includes any unwanted signals such as distortion and intermodulation products that may occur during call set-up signalling.*

6.4.4

Signal timing

The duration of transmitted DTMF signals shall comply with the following requirements:-

- (a) The minimum valid tone duration shall be 60 ms, and the minimum inter- digital pause shall also be 60 ms, exclusive of any rise and fall times.
- (b) The valid tone duration shall be timed when the signal is within the acceptable tolerances stated in clause 6.4.2 and clause 6.4.3.

6.4.5

In-band DTMF signalling

For the purposes of communicating with IVR systems and other remote control functions it is necessary that the FXO can either generate DTMF signals during a call in progress or pass them transparently from an FXS or system dependent phone. In both cases the frequency, level, distortion and timing requirements of 6.4.2 to 6.4.4 above shall be complied with.

6.5

D.C. Characteristics

6.5.1

Off-hook D.C. line characteristics

(1) For all devices designed for connection to a PSTN line, to ensure satisfactory operation, the d.c. voltage versus current characteristics in the off-hook condition shall be no greater than the upper limit curve shown in Figure 6.5.1. This curve is formed by straight lines joining the following co-ordinates:-

UPPER LIMIT CURVE	
CURRENT (mA)	VOLTAGE (Volts)
0	9
20	9
60	27

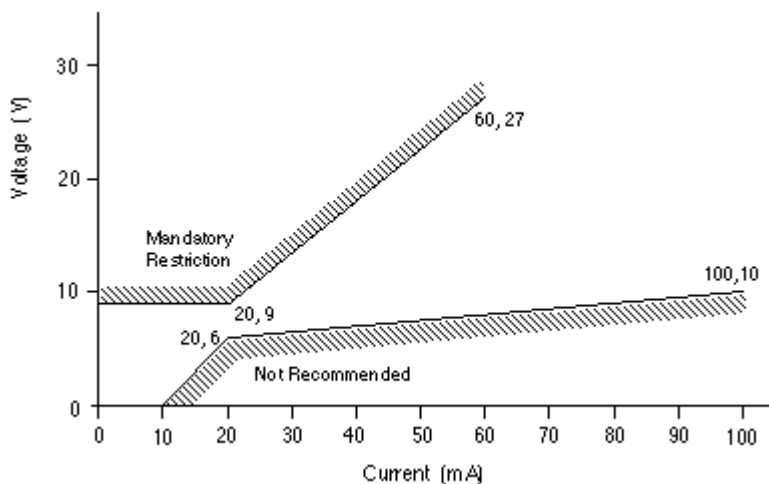

FIG. 6.5.1 LIMITS OF D.C. CHARACTERISTICS

(2) The FXO shall retain its full capability with a line current of 20 mA.

6.5.2

Supervisory conditions

(1) Line seizure: FXO equipment shall initiate an outgoing call by going off-hook and drawing d.c. line current from the PSTN line.

(2) Ring trip: FXO equipment shall answer an incoming call (on receipt of incoming ringing), by going off-hook and drawing d.c. line current from the PSTN line.

(3) Call release: The FXO equipment shall terminate a call by going on-hook and breaking the line current. At this point it shall be ready to receive a subsequent incoming call.

(4) To ensure satisfactory performance of each of these supervisory functions, the device shall satisfy the mandatory requirements given in clause 6.3.

- *An increasing number of line feeds have limited current sources (such as those provided by "derived circuit" equipment and many PABX's). For this reason it is not permitted to have customer equipment incorporating constant current sinks as a means of holding the line in a seized condition. This is reflected in the d.c. characteristic upper limit curve having a finite slope from the 20 mA minimum rather than a vertical constant current characteristic.*

(5) FXO equipment shall automatically release any call in progress within 5 seconds of failure of its power source.

6.5.3

Line breaks

The duration of any undefined interruption or random break in the d.c. path caused by the equipment shall not exceed 9 ms.

6.5.4

On-hook line current

In the on-hook state the direct current drawn from a nominal 50 V supply by the FXO equipment shall be not greater than 120 μ A.

6.5.5

Recall and call waiting

(1) The recall facility is in the form of a timed break in the holding loop condition during a call, and it is known as "timed-break recall" or "TBR".

(2) Where provided, the TBR of customer products shall be within the range 500 ms to 800 ms. If a product cannot be set to operate within this range then the TBR function shall be disabled. Also, a suitable explanation shall be inserted in the User Instructions advising users that the facility is not available.

6.6

Ringling

6.6.1

Ringer sensitivity and loading

6.6.1.1

General operation

(1) During assessment of 'ringer sensitivity' and 'ringer loading', ringing detectors shall operate reliably.

(2) Where the private network is intended to utilise the Distinctive Alert codes, the sensitivity and loading requirements shall be tested for each of the Distinctive Alert cadences (DA1-DA4) which are intended to be used. Unless the FXO is specifically set to recognise one code only, all FXO equipment shall respond to the Telecom Standard ringing (DA1).

6.6.1.2

Ringer sensitivity

(1) Where ringing detectors are provided, the 'ringer sensitivity (RS)' on a scale of 0 - 5 shall be determined using the test set-up shown in Fig. 7-1. The method used for determining 'RS' is described in detail in Appendix 2. This applies to both 2-wire and 3-wire devices.

(2) Ringing detectors shall not operate to ringing voltages of 30 Vp-p or less.

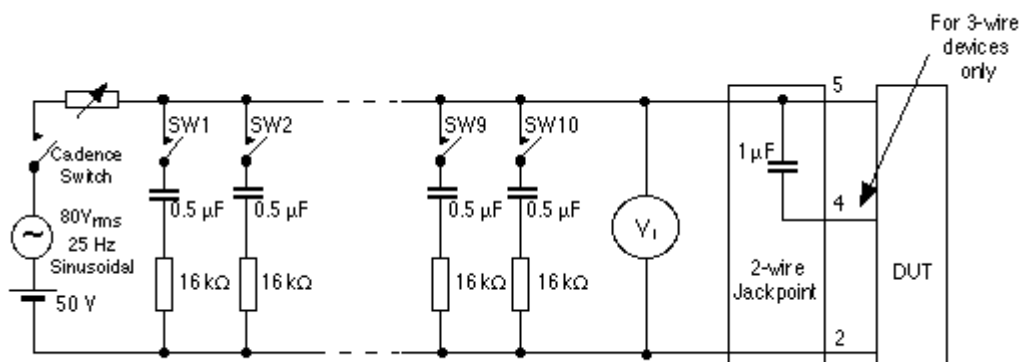

FIG. 7-1 TEST SET-UP FOR 'RN' ASSESSMENT

6.6.1.3

Ringer loading

As for ringer sensitivity, all ringing detectors shall be assigned a 'ringer loading (RL)' number on a scale of 0 - 5, which shall be determined using the test set-up shown in Fig. 7-1. The method used for determining this ringer loading number is described in detail in Appendix 2. This applies to both 2-wire and 3-wire devices.

6.6.2

Ringling number (RN)

(1) The ringing number (RN) allocated shall be in the range 0.5 - 5 and shall be equal to the higher of the following:-

- (a) Ringer sensitivity number (ref clause 6.6.1.2).
- (b) Ringer loading number (ref clause 6.6.1.3).

(2) If the RN derived as above equates to zero, then it shall be rounded up to 0.5.

- *Telecom reserves the right to increase the value of 'RN' above that derived in (1) and (2) if other factors, such as excessive 'on-hook d.c.', indicate the need. However, this is expected to occur in only rare and exceptional cases.*

(3) For correct operation, the total of the RN's of all devices connected to a PSTN line at any given time should not exceed 5.

- *Note that the RN assessment is not intended to be an accurate measurement, but is primarily a simple guide to customers as to the total number of items they may connect to a line.*

(4) Where equipment is not intended to be connected to a line in parallel with other terminal equipment, this shall be clearly stated in the user instructions.

- *Some items of series connected equipment do not normally have other devices connected in parallel with their PSTN line port. In cases where this possibility is envisaged, then the factors influencing the RN should be considered in the design.*

6.7

Physical Connection

There are no specific requirements for the connection of FXO equipment to the network. It is expected that such equipment will be professionally installed, and appropriate connection methods will be used.

6.8

Supplementary Services

6.8.1

Switch-hook Flash

Switch-hook flash is the mechanism by which access to supplementary services such as call waiting and three way calling is achieved. The timing for switch-hook flash is given in clause 6.5.5 of this Specification.

6.8.2

Caller ID

6.8.2.1

General

(1) Analogue CLI equipment designed for the Telecom 'Caller Display' service uses the on-hook data transmission facilities described in Technical Document TNA 102, Sections 10 and 11.

6.8.2.2

On-hook impedance

(1) During the reception of data the receiver of an on-hook device may, for the purpose of improving impedance matching, terminate the line with a more suitable a.c. impedance (e.g. BT3) than that stated in clause 6.3.4.1.2 of this Specification. In this case the following shall apply:-

(a) This impedance shall be removed either when the second ring cadence occurs (preferably just before), or when another device on the same line goes off-hook.

(b) If coded ringing is implemented on the same line, the unit shall also decode the ringing to determine when the impedance should be applied and removed.

- *There is potential for confusion between DA2 and DA4 because of the extended silent period between the first two bursts of ringing.*
- *The difference should be noted between the standard Telecom New Zealand off-hook impedance BT3 (ref clause 4.5.1) and the 600 ohm plus 2.16 μ F series network commonly used on North American products. However, it is not anticipated that this difference will cause any problems for on-hook data transmission.*

(2) At all other times, the on-hook impedance shall be as stated in clause 6.3.4.1.2 of this Specification.

6.8.2.3

Data capture

(1) The receivers of all devices which use on hook data transmission shall be capable of receiving data in the format described in Technical Document TNA 102, Section 10. Both single data message format (SDMF) and multiple data message format (MDMF) shall be supported.

(2) Receivers should be capable of receiving data during any of the four ringing cadences used (see clause 11.4.3(a) above). If not, a suitable warning shall be included which clearly explains to the customer which DA codes the device is compatible with. Fig. 11-3 illustrates the timing requirements for analogue CLI devices with respect to the different DA codes.

- *It should be noted that the data is limited to 'Time/Date', Area code and 'Directory Number' when sent with DA3 and DA4 cadences.*

(3) Receivers shall perform satisfactorily when connected via a zero, 3 km and 6 km artificial line (see Fig. 4-1(b) in Section 4). In each case the test shall be carried out with and without a ringer built out to a RN of 5 (ref. Section 7) connected in parallel. The ringer shall remain operational for all the tests in which it is connected.

(4) All messages that contain corrupted data, as indicated by an incorrect checksum, shall be discarded.

(5) It is recommended that the receiver functions should be independent of the exact length of the CSS and pre-message mark signal.

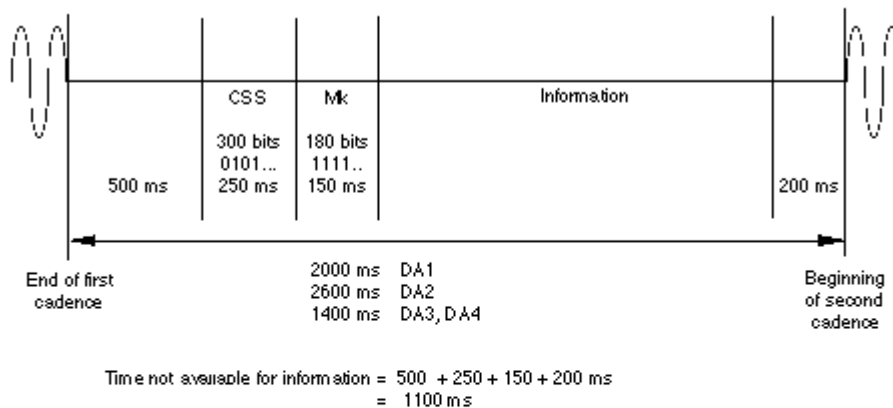

Ringling Cadence	Time available for information	Total No of Characters *1	Characters Available for ACLIP Directory number Single Data Message Format *2	Characters Available for ACLIP Directory number and Name Multiple Data Message Format *3
DA 1	900 ms	108	97	91
DA 2	1500 ms	180	169	163
DA 3, 4	300 ms	36	25	19

- These are not included in the checksum and do not carry any information except to function as a 'wake up' signal.

Notes:

*1 10 bits per character, 1200 bps

*3 Overhead for MDMF

Message Type - 1 Character

Message Length - 1 Character

Date/Time Parameter Type - 1 Character

Date/ Time Parameter Length - 1 Character

Date/Time - 8 Characters

Directory Number Parameter Type - 1 Character

Directory Number Parameter Length - 1 Character

Directory Number - X Characters

Directory Number - X Characters

Name Parameter Type - 1 Character

Name Parameter Length - 1 Character

Name - Y Characters

Checksum - 1 Character

Total Characters = 17 + X + Y

Checksum - 1 Character

Total Characters = 11 + X

FIG. 11-3 TIMING DIAGRAM FOR ANALOGUE CALLING LINE IDENTIFICATION SIGNALS

6.8.2.4

Number format passed from the network

(1) For local and national calls, the number sent forward from the Telecom network is in the format "area code" plus "customer number". No "0" national call prefix is passed forward from the network.

- *This is the format used within the Telecom network and between New Zealand networks for passing calling numbers. For such applications, the "0" has no meaning.*
- *Display equipment designers should note that there is no format differentiation between national and local calls.*

(2) For incoming international calls entering New Zealand via a Telecom International Exchange, the digits "0000" are currently passed forward. This will continue to be the practice for any international numbers that are either not available or need to be withheld in the future for any reason.

- *The actual numbers are currently withheld to protect the privacy of overseas callers.*
- *It should be noted that not all international calls arrive in New Zealand via the Telecom Gateway. Many arrive via other carriers.*

(3) In due course, some international numbers are expected to be made available to New Zealand customers. Where such numbers are available for presentation, the number sent forward from the Telecom network will be in the format "country code" plus "area code" plus "customer number". No "00" international call prefix will be passed forward from the network. As a result, there could be confusion between national and international numbers on display units.

- *When international numbers are available for presentation to New Zealand customers, the number length may be any length up to 15 digits. See warning note on clause 11.4.6.*
- *The timing for such a service introduction is unknown at this stage.*

(4) For incoming calls wholly within a Centrex group, the number passed forward will be the extension number used within that Centrex customer's network. The number length will be within the range of 2 to 7 digits.

(5) The number actually passed from the network may not relate to a specific person or line.

- *For example, where the pilot number of a DDI PABX group is passed forward, a display user dialling that number is likely to reach the PABX operator, not the person who originally made the call. Similarly, a small percentage of displayed numbers may not correspond with a number that can be called back.*

6.8.3

Distinctive alert ringing

A private network which extends Distinctive alert ringing cadences from the PSTN to the FXS port shall meet the requirements of clause 6.6 of this specification and reproduce the correct cadences at the FXS port. See also clause 5.

6.8.4

Fax/Voice band modem transport

If the FXO equipment is connected to the FXS by either low bit rate transmission, or via packets such as IP, voiceband data such as fax or V.92 modems may not operate at full speed, or may not operate at all. If special measures are taken to enable voiceband data to be transported these shall be noted. See clause 6.9.4 for functional test.

- *The normal method of dealing with voiceband data is to demodulate the analogue signals, transport them as data, and re-modulate them at the FXS/FXD for passing onto the PSTN/ISDN.*

6.8.5

Incoming Call DDI

Where the FXO supports incoming call DDI, it shall meet the requirements of PTC107.

6.9

Functional requirements

6.9.1

General

This Section covers the functional requirements for FXO equipment. Many of these requirements depend on compatible FXS equipment or system dependent phones, and tests shall be performed with such suitable equipment. Telepermits will be granted to FXO equipment subject to use with the FXS equipment/phone with which it was tested or equipment with equivalent functionality. It is the responsibility of the Telepermit holder to ensure that alternative FXS equipment/phones are not only Telepermitted but have also been thoroughly checked against the functional requirements of this specification.

6.9.2

Call Set-up (outgoing call)

6.9.2.1

Signalling

(1) When a number is dialled from the FXS or phone, the FXO shall seize the line and commence dialling within 2 seconds of the last number being either received from CPE connected to the analogue port of the FXS equipment or a system specific phone. This time includes a minimum 1 second pause between seizing the line and the commencement of dialling where no dial tone detection is provided.

- *Refer PTC200 clause 8.1.2*

(2) If the FXO waits for the last digit to be dialled before seizing the line, it requires prior knowledge of the number length, or imposition of very short interdigit timeout. An alternative is to seize the line and begin dialling as the first digit is received, or even when the CPE initiating the call goes off-hook. The FXO must then check the network for NU tone which indicates that either a non-existent number has been dialled, or the interdigit pause is too long.

The NU tone or other suitable indicator shall be sent from the FXO to the FXS or phone.

(3) The correct number shall be dialled from the FSO network connection.

6.9.2.2

Call progress indicators

The following call progress indicators shall be either recognised by the FXO and indicators sent to the FSX equipment or phone where suitable indicators shall be regenerated, or an audio path shall be maintained from the FXO during call set-up.

(1) Ringing tone (as an indication that the called party phone is ringing)

(2) Busy Tone (as an indication that the called party is busy)

(3) Recorded Announcement (used to indicated a variety of conditions from the network)

(4) Disconnect tone (to indicate that the other party has hung up)

(5) NU (to indicate that the number dialled does not currently exist)

(6) Network congestion tone (to indicate that the network cannot complete the call at that time)

- *Tones can be transmitted reliably over a link using ITU-T C.711 codecs, but not necessarily over a link using some low bit rate codecs which are optimised for human voice characteristics.*
- *The tones used on the Telecom Network are detailed in TNA 102.*

6.9.2.3

Call connect

A bothway audio connection shall be established within 200ms of cessation of ringing tone.

6.9.2.4

Call clear

(1) If a call is aborted during setup, the FXO shall clear down any network connection within 5 seconds.

(2) If the PSTN times out during call setup and returns NU tone, then the FXO shall send an indication to the FXS equipment or phone, and clear the PSTN connection

6.9.2.5

Call in progress

(1) Bothway audio connection shall be maintained until one or other party clears the call.

(2) While a call is in progress, DTMF tones received from the PSTN shall be forwarded to the FSX equipment or phone

(3) While a call is in progress, DTMF tones received by the FXS equipment from CPE connected to its analogue port or DTMF tones generated by a system phone shall be forwarded to the PSTN. Where the DTMF signals are regenerated in the FXO equipment, they shall meet the requirements given in section 6.4 of this specification.

- *Where G.711 codecs are employed, the DTMF can be carried in-band in both directions, but with some low bit rate codecs, it may be necessary to generate the DTMF at both the FXS analogue interface and the FXO network interface.*

(4) A Switch hook flash generated by CPE connected to the analogue port of the FXS equipment or from a system phone shall be correctly regenerated at the FXO interface.

6.9.2.6

Call Clear

6.9.2.6.1

Call Clear from private network

(a) The FXO shall clear down the call at the interface to the PSTN within 5 seconds of call clear signal indicating that a system phone has gone on-hook, or CPE connected to the analogue port of the FXS equipment has gone on-hook.

(b) Where a phone or FXS becomes disabled, by either loss of power or network connection, it will be unable to send a call clear message e.g. a SIP "bye". In this circumstance the FXO will need to implement an activity timeout, and clear the network connection. Ideally this timeout should be reasonably short, particularly if the call is charged by duration. If VAD is not implemented, the cessation of RTP packets can indicate that the terminal has been disconnected or powered down, and the network call shall be terminated within 5 seconds. However if VAD is implemented there is no way of telling the difference between a long pause in activity or the loss of terminal function. Where VAD is an option there shall be a timeout implemented, and user warnings indicating that chargeable calls could be charged more than expected due to the call being held up by the FXO.

- *In practice it will probably be apparent to the party on the other end of the call that the call has become ineffective and they will terminate the call at which time charging will cease.*

6.9.2.6.2

Call Clear from PSTN

When the PSTN party clears the call, the FXO shall terminate the PSTN connection and send a call clear indication to the FXS equipment or system phone.

6.9.3

Incoming call from PSTN

(1) Ringing shall be recognised by the FXO equipment and indication sent to the FXS or system phone, so that an alert is presented to the user within 2 seconds of ringing being presented at the FXO interface.

(2) When an answer signal is received from the FXS or system phone, the PSTN connection shall be looped with a d.c. impedance of not more than 1000 ohms and a bothway audio transmission path shall be established.

(3) If Caller ID is implemented, it shall conform to the specifications given in TNA 102 sections 9 and 11.

(4) If DDI is implemented, the call shall be routed to the appropriate FXS port or system phone.

6.9.4

Voiceband Data

If the FSX makes special provision for carrying voiceband data, a fax or data call to a compatible modem (fax or data modem) on the PSTN, and receive a data call from a compatible modem on the PSTN.

7.0

FXD Requirements

7.1

General

This Section covers the requirements for a standalone FXD unit for interfacing a private network to a digital PSTN line such as ISDN or E1.

7.1.1

Test Configuration

The Test Laboratory shall document in the form of a block schematic, the configuration used for testing this section. This shall include the make and model of the FXS used to complete some of the tests, and state where the TRP is located.

- *The TRP would normally be at the ethernet interface to the FXO, or in the case of a circuit switched PBX at the centre of the switch block.*
- *Examples of the block schematic are given in the test setups in Appendix 1 of this specification.*

7.1.2

Configuration Details

Actual setup configurations shall be recorded in the test report for all test results in this section. At least one FXO configuration must be able to achieve compliance for all parts of this specification.

7.2

Electrical Safety

The unit shall meet the requirements of AS/NZS 60950. This includes the following FXD components:

- (a) Power Supply
- (b) LAN/WAN port(s) isolation to TNV2

7.3

Transmission

7.3.1

FXD Loss Plan

- (a) Loss from TRP to FXD Digital (ISDN) trunk: 0.5 dB to -0.5 dB,
Objective: 0 dB
- (b) Loss from FXD Digital (ISDN) trunk to TRP: 0.5 dB to -0.5 dB,
Objective 0 dB

7.3.2

Attenuation Frequency Distortion

The loss distortion with frequency between the ISDN/E1 port and the TRP and the TRP and the digital port shall be within the following limits, using an input level of -10 dBm0.

Frequency (Hz)	Loss relative to the loss at 1000Hz (dB)
300 - 400	+1, -0.3
400 - 600	+0.75, -0.3
600 - 2000	+0.35, -0.3
2000 - 2400	+0.45, -0.3
2400 - 3000	+0.7, -0.3
3000 - 3400	+1.7, -0.3

- Reference ITU Recommendation Q.552

7.3.3

Variation of Gain with input level

With a 1000 Hz sinewave signal applied to either the ISDN/E1 port 0dB_r point at a level between -55 dB_{m0} and +3 dB_{m0}, the gain of that signal relative to the gain of a signal at an input level of -10 dB_{m0}, shall be within the following limits:

Input level (dB _{m0})	Gain Variation (dB)
-55 to -50	+/- 1.6
-50 to -40	+/- 0.6
-40 to +3	+/- 0.3

- ITU-T Recommendation Q.552 clause 3.1.1.4

7.3.4

Delay

(1) Delay shall be measured between the network connection and the TRP in both directions for the following configurations:

- Each different codec type supported by the product
- With VAD turned on and off
- With Jitter buffer set to minimum and maximum lengths.

(2) The maximum delay acceptable for calls to other networks is 50ms. For Telepermitting purposes, this must be achievable on at least one of the above configurations. Where there are configurations which cannot meet this requirement, the instructions must be included warning that these configurations must not be used for calls which leave the private network.

- This allows for 50 ms delay in the FXS or phone and 10ms delay in the private network itself to meet the 110 ms total shown in Fig 4.3.9.2. In practice the delays in the FXS/phone and FXO should be less than 50 ms to allow switching/routing within the private network.

7.3.5

Codec Type

All FXD equipment shall have a G.711 codec. Other codecs may also be used, but cannot be tested using conventional test techniques. A list of all

codecs used and the method of implementing them shall be provided. This includes information as to whether the codec is fixed as part of the initial system set-up, or is selected dynamically on a call by call basis depending on the call destination or other parameters.

- *In many implementations there will be configurations where the FXD does not use a codec at all. The interface merely reformats a digital voice stream between a packet or TDM format without changing the voice coding at all.*

7.3.6

Echo

(1) Where the mean one way propagation time exceeds 15ms echo cancellers should be deployed. VoP and wireless technologies are likely to have inherent delays exceeding 15ms and would be expected to have echo cancellers fitted. Assuming echo cancellers are fitted, values of 65dB and 110dB are used for TELR and WEPL respectively in calculating the delay impairment factor Id.

(2) The configuration and parameters of an echo canceller shall be stated if used in the FXD.

7.4

Signalling

7.4.1

ISDN

ISDN interfaces shall meet the requirements of the following Telecom Specifications:

PTC 131	Basic Rate Access Layer 1
PTC 132	Primary Rate Access Layer 1
TNA 133	Layer 2
TNA 134	Layer 3

The FXD shall map the signalling functions between the private network and the ISDN interfaces in accordance with the following requirements:

7.4.2

Outgoing Calls

The FXD may employ either en-bloc or overlap signalling at the ISDN interface. The relationship between the ISDN interfaces when using these signalling modes shall be as follows:

7.4.2.1

En-bloc Signalling

The outgoing call set-up sequence shall be in accordance with TNA 134 §C5.1.1, except where modified as follows:

When the complete number to be dialled into the ISDN has been received from the FXS or system phone, the FXD shall:

- send a SETUP message in accordance with TNA 134 C3.1.16 containing the correctly formatted address digits.

- (b) either enable the transmission path in both directions, or send appropriate messages to the FXS/phone for call progress tones to be generated locally consistent with the network messages.
- (c) The coding of the Bearer Capability (BC) and where used, High Layer Compatibility (HLC) and Low Layer Compatibility (LLC) message elements shall be in accordance with TNA 134 §4.5.5, §4.5.16, and §4.5.18 respectively. The Bearer Capability Information Transfer Capability shall be coded 3.1 kHz Audio
- (d) The SETUP Message originated from the FXD shall contain Progress Indicator No 3, "Originating address not ISDN".

7.4.2.2

Overlap Signalling

The outgoing call set-up sequences shall be in accordance with TNA 134 C5.1.3 overlap signalling requirements except where modified as follows:

- (a) For those cases where call progress tones are generated locally by the FXS/phone, detection of an off-hook condition dial tone should be applied and the FXD shall send a SETUP message (without address information) to the ISDN interface.

For those cases where the FXS/phone does not generate tones locally, on detection of an off-hook condition, the FXD shall cause a SETUP (without address information) to be sent by the ISDN Interface and, when a SETUP ACKNOWLEDGE message is received, enable the transmission path in both directions to and from the B-channel specified in that message.

- *This is to allow the network tones to be sent in-band to the FSX/phone*
- *Where appropriate, on receipt of the first address digit on the analogue interface, the FXS/phone shall cease application of dial tone.*

- (c) Subject to the requirements of TNA 134, each address digit received from the FXS/phone shall cause an equivalent address character to be transmitted by the FXD to the ISDN interface in an INFORMATION message.
- (d) The coding of the Bearer Capability (BC) and where used, High Layer Compatibility (HLC) and Low Layer Compatibility (LLC) message elements shall be in accordance with TNA 134 §4.5.5, §4.5.16, and §4.5.18 respectively. The Bearer Capability Information Transfer Capability shall be coded 3.1 kHz Audio
- (e) The SETUP Message originated from the FXD shall contain Progress Indicator No 3, "Originating address not ISDN".

7.4.3**E1**

E1 interfaces shall meet the requirements of PTC 107

7.4.4**In-band DTMF signalling**

For the purposes of communicating with IVR systems and other remote control functions it is necessary that the FXD can either generate DTMF signals during a call in progress or pass them transparently from an FXS or system dependent phone.

7.4.4.1**DTMF frequencies**

(1) The allocation of DTMF signalling frequencies shall be as follows:-

Low Group (Hz)	High Group (Hz)			
	1209	1336	1477	1633
697	1	2	3	A
770	4	5	6	B
852	7	8	9	C
941	*	0	#	D

- (2) Each transmitted frequency shall be within $\pm 1.5\%$ of the nominal frequency.
- (3) DTMF signalling devices shall support at least the 10 numeric digits plus '*' and '#' symbols.

- The 'A', 'B', 'C' and 'D' are rarely used at the date of issue of this Specification.

7.4.4.2**DTMF signalling requirements**

(1) All devices shall satisfy the following requirements during the transmission of DTMF signalling:-

- (a) Each individual signalling tone of a burst, shall be at a power level between -4 dBm and -13 dBm measured at the PSTN 0 dBr point.
- (b) There shall be a pre-emphasis in the range 0 to 3 dB for the high frequency tone group relative to the low frequency group.
- (c) During signalling:-
- (i) The individual power level of any extraneous frequency in the range 300 Hz to 5 kHz during signalling shall be at least 20 dB below that of the signalling frequency with the lowest level.

- (ii) The one minute mean power level in any 3 kHz bandwidth contained wholly above 5 kHz shall be at least 20 dB below that of the signalling frequency with the lowest level.

- "Noise" includes any unwanted signals such as distortion and intermodulation products that may occur during call set-up signalling.

7.4.4.3

Signal timing

The duration of transmitted DTMF signals shall comply with the following requirements:-

- (a) The minimum valid tone duration shall be 60 ms, and the minimum inter- digital pause shall also be 60 ms, exclusive of any rise and fall times.
- (b) The valid tone duration shall be timed when the signal is within the acceptable tolerances stated in clause 7.4.4.1 and clause 7.4.4.2.

7.5

Supplementary services

7.5.1

Switch-hook flash

Switch-hook flash is the mechanism by which an analogue phone accesses supplementary services such as call waiting and 3-way calling. An FXS receiving a switch-hook flash will send a message to the FXO/FXD which must then regenerate the signal and pass it to the network. For ISDN connected FXD equipment, the switch-hook flash is implemented by the FXD sending a FEATURE ACTIVATION element with the feature identifier number set to 1, to the ISDN (see PTC134 clause 4.7)

7.5.2

Distinctive Ringing

Distinctive ringing may be generated in the FXS or phone as a result of coding in the SIGNAL INFORMATION element in a CENTREX environment (clause 4.5.28) or Multiple Subscriber Number which is described in Part D of TNA 134.

7.5.3

Caller ID

Caller ID is described in Part D of TNA 134.

7.5.4

Fax/Voice band modem transport

If the FXD equipment is connected to the FXS by either low bit rate transmission, or via packets such as IP, voiceband data such as fax or V.92 modems may not operate at full speed, or may not operate at all. If special measures are taken to enable voiceband data to be transported these shall be noted. See clause 7.6.4 for functional test.

- *The normal method of dealing with voiceband data is to demodulate the analogue signals, transport them as data, and re-modulate them at the FXS/FXD for passing onto the PSTN/ISDN.*

7.5.5

Other Supplementary Features

There are other supplementary features available on ISDN which do not have direct equivalents on the PSTN. These are described in TNA 134 Part D, and if implemented shall be in accordance with that clause. These may be accessed directly by a system phone, but if an analogue phone is connected to an FXS, then such features could be activated by DTMF tones.

7.6

Functional requirements

7.6.1

General

This Section covers the functional requirements for FXD equipment. Many of these requirements depend on compatible FXS equipment or system dependent phones, and tests shall be performed with such suitable equipment. Telepermits will be granted to FXD equipment subject to use with the FXS equipment/phone with which it was tested or equipment with equivalent functionality. It is the responsibility of the Telepermit holder to ensure that alternative FXS equipment/phones are not only Telepermitted but have also been thoroughly checked against the functional requirements of this specification.

7.6.2

Call Set-up (outgoing call)

7.6.2.1

Signalling

1. When a number is dialled from the FXS or phone, the FXD shall complete signalling the network within 3 seconds of the last digit being received either from CPE connected to the analogue port of the FXS equipment or from a system specific phone.
2. The appropriate number shall be forwarded from the FXD network connection.

7.6.2.2

Call progress indicators

The following call progress indicators shall either:

- (a) be recognised by the FXD and indicators sent to the FSX equipment or phone where suitable indicators shall be regenerated, or,
 - (b) extend and maintain an audio path from the FXD during call set-up.
1. Ringing tone (as an indication that the called party phone is ringing)
 2. Busy Tone (as an indication that the called party is busy)

3. Recorded Announcement (used to indicate a variety of conditions from the network)
 4. Disconnect tone (to indicate that the other party has hung up)
 5. NU (to indicate that the number dialled does not currently exist)
 6. Network congestion tone (to indicate that the network cannot complete the call at that time)
- *Tones can be transmitted reliably over a link using ITU-T G.711 codecs, but not necessarily over a link using some low bit rate codecs which are optimised for human voice characteristics.*

7.6.2.3

Call connect

A bothway audio connection shall be established within 200ms of cessation of ringing tone.

7.6.2.4

Call clear

- 1 If a call is aborted during setup, the FXD clear down any network connection within 5 seconds.
- 2 If the PSTN times out during call setup and returns NU tone, then the FXD shall send an indication to the FXS equipment or system phone, and clear the PSTN connection

7.6.2.5

Call in progress

1. Bothway audio connection shall be maintained until one or other party clears the call.
 2. While a call is in progress, DTMF tones received from the PSTN shall be forwarded to the FXS equipment or system phone
 3. While a call is in progress, DTMF tones received by the FXS equipment from CPE connected to its analogue port or DTMF tones generated by a system phone shall be forwarded to the PSTN. Where the DTMF signals are regenerated in the FXD equipment, they shall meet the requirements given in section 6.4 of this specification.
- *Where G.711 codecs are employed, the DTMF can be carried in-band in both directions, but with some low bit rate codecs, it may be necessary to generate the DTMF at both the FXS analogue interface and the FXO network interface.*
4. A Switch hook flash generated by CPE connected to the analogue port of the FXS equipment or from a system phone shall be correctly regenerated at the FXD interface.

7.6.2.6

Call Clear

7.6.2.6.1

Call Clear from private network

(a) The FXD shall clear down the call at the interface to the PSTN within 5 seconds of receiving a signal indicating that a system phone has gone on-hook, or CPE connected to the analogue port of the FXS equipment has gone on-hook.

(b) Where a phone or FXS becomes disabled, by either loss of power or network connection, it will be unable to send a call clear message e.g. a SIP "bye". In this circumstance the FXD will need to implement an activity timeout, and clear the network connection. Ideally this timeout should be reasonably short, particularly if the call is charged by duration. If VAD is not implemented, the cessation of RTP packets can indicate that the terminal has been disconnected or powered down, and the network call shall be terminated within 5 seconds. However if VAD is implemented there is no way of telling the difference between a long pause in activity or the loss of terminal function. Where VAD is an option there shall be a timeout implemented, and user warnings indicating that chargeable calls could be charged more than expected due to the call being held up by the FXD.

- *In practice it will probably be apparent to the party on the other end of the call that the call has become ineffective and they will terminate the call at which time charging will cease.*

7.6.2.6.2

Call Clear from PSTN

When the PSTN party clears the call, the FXD shall terminate the PSTN connection and send a call clear indication to the FXS equipment or system phone.

7.6.3

Incoming call from PSTN

1. An incoming call from the PSTN shall be recognised by the FXD equipment and indication sent to the appropriate FXS or system phone, so that an alert is presented to the user within 2 seconds of an incoming call being indicated at the FXD interface.
2. When an answer signal is received from the FXS or system phone, a bothway audio transmission path shall be established within 100ms.
3. If Caller ID or distinctive alert is implemented, the correct numbers shall be received by the FXS or system phone or the correct ringing codes shall be regenerated at the FXS or system phone.

- *These functions are not mandatory, but must operate correctly if implemented or have user documentation warnings and instructions for disabling them.*

7.6.4

Voiceband Data

If the FSX makes special provision for carrying voiceband data, a fax or data call to a compatible modem (fax or data modem) on the PSTN, and receive a data call from a compatible modem on the PSTN.

8.0

System Specific (including IP) Telephone Requirements

8.1

General

(1) This Section covers the requirements for a System Specific Telephone. At some future date, IP phones may be separately specified, when (if) standards evolve. This section also includes "soft" phones where a headset or handset is connected to a PC and the control/ supervisory functions are performed via the PC screen/keyboard/mouse.

(2) Where an FXS unit is intended for connection to system dependent phones, the phone and the FXS are tested together as a system dependent phone against the requirements of this section.

8.1.1

Test Configuration

The Test Laboratory shall document in the form of a block schematic, the configuration used for testing this section. This shall include the make and model of the FXO/D or Trunk interface used to complete some of the tests, and state where the TRP is located.

- *The TRP would normally be at the ethernet interface to the phone, or in the case of a circuit switched PBX at the centre of the switch block.*
- *Examples of the block schematic are given in the test setups in Appendix 1 of this specification.*

8.1.2

Configuration Details

Setup configurations shall be recorded for all test results in this section. At least one configuration must be able to achieve compliance for all parts of this specification.

8.2

Electrical Safety

The unit shall meet the requirements of AS/NZS 60950. This includes the following FXS components:

- (a) Power Supply
- (b) LAN/WAN port(s) isolation to TNV

8.3

Transmission

8.3.1

Digital Phone Loudness Rating

(1) The phone loudness rating shall comply with the following limits:

- (a) SLR to TRP: +5 dB to + 11 dB, **Objective: +8 dB**
- (b) RLR to TRP: -1 dB to + 5 dB, **Objective: +2 dB**

(2) The Loudness ratings shall be measured using the method described in ITU-T Recommendations P.64, P.65 and P.79.

- See also PTC220 clause 4.3.5.1

8.3.2

Side Tone Masking Rating (STMR)

The STMR shall be in the range 7 - 25 dB, **Objective: 10 - 15 dB**

Where the STMR is less than 7 dB, the users own voice will sound so loud, that they will tend to lower their voice. If the STMR is greater than 20, the phone sounds dead

The STMR shall be measured using the method described in ITU-T Recommendations P.64, P.65 and P.79.

8.3.3

Weighted Terminal Coupling Loss (TCLw)

The Terminal Coupling Loss is a measure of the acoustic loss between the earpiece and microphone on a handset. If this loss is too low it will be heard as echo from the party at the other end of the call. The TCLw be not less than 55 dB (ref ITU-T Rec P.1010)

The STMR shall be measured using the method described in ITU-T Recommendations P.310.

8.3.4

Frequency response

8.3.4.1

Send Frequency Response

The send frequency response, from the Mouth Reference Point (MRP) to the digital interface, shall be within the mask given in Table 8.3.3.1 .

- Ref ETSI TBR8 clause 8.2.1.1

Frequency (Hz)	Upper limit (dB)	Lower Limit (dB)
100	-10	
200	0	
300	0	-14
1000	0	-8
2000	4	-8
3000	4	-8
3400	4	-11
4000	0	

Table 8.3.3.1 Send Frequency response mask

- All values are dB on an arbitrary scale

8.3.4.2

Receive Frequency Response

The receive frequency response, from the Mouth Reference Point (MRP) to the digital interface, shall be within the mask given in Table 8.3.3.1 .

- *Ref ETSI TBR8 clause 8.2.1.1*

Frequency (Hz)	Upper limit (dB)	Lower Limit (dB)
100	-6	
200	0	
300	2	-9
500	*	-7
1000	0	-7
3000	4	-7
3400	4	-12
4000	4	

Table 8.3.3.2 Receive Frequency response mask

* the limit at intermediate frequencies lies on a straight line drawn between the given value on a logarithmic (frequency) - linear (dB) scale

- *All values are dB on an arbitrary scale*

8.3.5

Delay

(a) The delay measured from the MRP (mouth reference point) to the TRP shall be less than 50 ms.

(b) The delay measured from the TRP to the ERP (ear reference point) shall be less than 50 ms

8.4

Signalling

The signalling protocols to and from a system Dependent phone will be proprietary to the system, but shall be capable of meeting the functional requirements of section 8.7 when used in conjunction with a suitable FXO/FXD.

8.5

User Interfaces

It is not mandatory that a phone be able to initiate outgoing calls **and** receive incoming calls. Where these functions are available they shall meet the following requirements:

8.5.1

Call setup

(a) Provision for entering phone number. If physical keypad is used, layout shall be as shown in Figure 8.4.1

1	2 ABC	3 DEF
4 GHI	5 JKL	6 MNO
7 PQRS	8 TUV	9 WXYZ
*	0	#

Figure 8.5.1 Keyboard layout

8.5.2

Incoming call alert

An incoming call alert can be implemented in a number of ways, the most common being audible. Other alerting methods commonly employed are visual and mechanical.

8.5.2.1

Alerting Characteristics

(1) The sound level for audible operation of a ringing detector, if provided, shall be at least 50 dBA when measured at 1 metre from the ringer in any direction while it is mounted on a hard surface.

- *It is recommended that a ringer be capable of producing a minimum acoustic level of 75 dBA. However, this is not mandatory.*

(2) There are no further requirements (e.g. frequency) specified for the audible characteristics.

- *The nature of the sound output signal and the frequency (or frequencies) used are regarded as marketing features.*

(3) There are no specific requirements for visual or mechanical alerting characteristics.

8.6

Physical Connection

Details of the method of physical connection shall be provided. It is expected that these will be compatible with standard wiring practices and will be via either an RJ45 or BT plug.

8.7

Functional requirements

8.7.1.1

General

This Section covers the functional requirements for system dependent phones. Many of these requirements depend on compatible FXO/FXD equipment, and tests shall be performed with such suitable equipment. Telepermits will be granted to a system phone subject to use with the FXO/FXD equipment with which it was tested or equipment with equivalent functionality. It is the responsibility of the Telepermit holder to ensure that suppliers and system integrators are aware of suitable such equipment.

8.7.2

Call Set-up (outgoing call)

8.7.2.1

Pre-dial Supervisory Tone (Dial Tone)

The provision of dial tone is optional.

8.7.2.2

Signalling

When a number is dialled from a system phone the appropriate number shall be dialled via the FXS/FXO network connection.

8.7.2.3

Call progress indicators

The following call progress indicators shall be presented to the user within five seconds of either the last digit being dialled or a send button or equivalent being activated. This will generally be tones presented to the user interface (handset, headset or loudspeaker) or could be via a visual display. The form of these indicators shall be recorded (frequency/ cadence for audio indicators, message or visual display for visual indicators).

- (1) Ringing (as an indication that the called party phone is ringing)
- (2) Busy (as an indication that the called party is busy)
- (3) Recorded Announcement (used to indicated a variety of conditions from the network)
- (4) Disconnect (to indicate that the other party has hung up)
- (5) NU (to indicate that the number dialled does not currently exist)
- (6) Network congestion (to indicate that the network cannot complete the call at that time)

8.7.2.4

Call connect

A bothway audio connection shall be established within 200ms of cessation of the ringing indicator.

8.7.2.5

Call clear

If a call is aborted during setup, the FXO/FXD shall clear down any network connection within 5 seconds.

8.7.2.6

Call in progress

(1) Bothway audio connection shall be maintained until one or other party clears the call.

(2) While call is in progress, keys pressed (or otherwise activated) on the dial pad shall cause the correct DTMF signal to be forwarded to the PSTN/ISDN at the FXO/FXD.

- *Where G.711 codecs are employed, the DTMF can be carried in-band in both directions, but with some low bit rate codecs, it may be necessary to generate the DTMF at the FXO/FXD network interface.*

(3) A Switch hook flash initiated at the system phone shall be correctly regenerated at the FXO/FXD interface.

8.7.2.7

Call Clear

8.7.2.7.1

Call Clear from System Phone

The FXO/FXD shall clear down the call at the interface to the PSTN/ISDN within 5 seconds of the system phone clearing the call.

8.7.2.7.2

Call Clear from other party (from the PSTN/ISDN)

When the other party clears the call, some form of indication should be provided at the system phone so that the user is aware that the call has terminated.

- *This clause is not mandatory, but desirable, particularly if voice activity detection is used, in which case there may be no indication at all that the call has been cleared.*

8.7.3

Incoming call (from PSTN/ISDN via gateway to system phone)

(1) Indication (audible ringing, visual or mechanical) shall occur within 5 seconds of the indication being sent to the FXO/FXD interface from the PSTN.

(2) Incoming call alert shall cease and a bothway audio transmission path shall be established within 100ms of the user answering the call.

(3) If Caller ID is implemented, the correct originating number shall be displayed.

9

Voice Mail System Requirements

9.1

General

This section covers the requirements for a voice mail module integrated into a private voice network.

- See Figure 3.1 for block diagram of showing the architecture of a private network with a voice mail system.

9.1.1

Test Configuration

The Test Laboratory shall document in the form of a block schematic, the configuration used for testing this section. This shall include the make and model of the FXO/D or Trunk interface used to complete some of the tests, and state where the TRP is located.

- The TRP would normally be at the ethernet interface to the phone, or in the case of a circuit switched PBX at the centre of the switch block.
- Examples of the block schematic are given in the test setups in Appendix 1 of this specification.

9.1.2

Configuration Details

Setup configurations shall be recorded for all test results in this section. At least one configuration must be able to achieve compliance for all parts of this specification.

9.2

Electrical Safety

The voicemail unit shall meet the requirements of AS/NZS 60950. This includes the following components:

- (a) Power Supply
- (b) LAN/WAN port(s) isolation to TNV

9.3

Transmission

9.3.1

Loss Plan

In a fully digital network, the loss from the TRP to the voice storage medium and replayed back to the TRP should be zero. However as the actual level at which messages will be recorded will vary with the length of the originating analogue access line, automatic gain control may be used so that recorded messages are replayed to the TRP at similar levels to prerecorded messages and prompts.

- (a) Loss from TRP to voice storage medium and replayed back to TRP: 0.5 dB to -0.5 dB, **Objective: 0 dB**

- (b) If agc is used, the playback level for voice to the TRP is -12 to 18 VU. Objective -15 VU and for pre recorded music at the TRP shall be -15 to -24VU.
- *There is no objective level for music as it will vary with the type of music recorded. It is recommended that provision for subjective testing and adjustment is available.*
 - *This clause also applies to music on hold facilities.*

9.3.2

Recorded message quality

(1) The speech quality of any recorded message transmission shall be suitably intelligible to the party on the other end of the call.

(2) Overall speech quality will be assessed subjectively by the testing authority and, in any cases of doubt, finally assessed by Access Standards at the time of application.

- *A suitable quantitative means of assessment may be introduced at some future date.*
- *Quantitative or subjective 'mean opinion score' assessment of speech quality is extremely complex and would be costly to the applicant. For this reason, no formal qualitative requirement is stated in this Specification.*

(3) Telecom reserves the right to re-assess the quality of the recorded speech transmission of any product after the grant of a Telepermit if there is evidence of substantial complaints from customers.

(4) If, during such a re-assessment, it is suitably established that the transmitted speech quality is unintelligible to another party when connected via the Telecom PSTN, then either:-

- (a) the speech quality shall be improved to the satisfaction of Telecom, or
- (b) the Telepermit will be cancelled.

(5) The cost of such re-assessment shall be born by the Telepermit holder. Also, any cost incurred by Telecom for investigation of complaints by customers relating to transmitted speech quality may be passed on to the customer using the transmitting device.